

Proceedings from
2025 Vehicle Dynamics seminar
**Model exchange
for virtual pre series**

version modified 2025-05-10 07:31

editors:

Bengt Jacobson bengt.jacobson@chalmers.se;

Lars Drugge larsd@kth.se;

The contents of these proceedings include both **presentations and poster material** and are published at <https://www.sveafordon.com/>, <https://research.chalmers.se/en/publication/541312>, and <https://kth.diva-portal.org/>.

The seminar was arranged by the workgroup Vehicle Dynamics Competence Area in Swedish Vehicular Engineering Association (SVEA, <https://www.sveafordon.com/>).

VDCA is a workgroup in:



SVEA is a member of:



Contents

Contents

Announcement of the Seminar

Participations

Introduction to the seminar

Presentation 1: *Dynamic simulation and beyond* Peter Sundström, Modelon

Presentation 2: *FMU factory from CAE to SAE* Edo Drenth, Volvo Autonomous Solutions

Presentation 3: *Target Cascading from Full Vehicle Dynamics Targets to System & Subsystem Vehicle Requirements* Axel Villandseie, Volvo Cars

Presentation 4: *Rolling resistance on roads with various weather and surface conditions* Mikael Askerdal, Volvo LV and Chalmers

Presentation 5: *FMU-based co-simulation for autonomous vehicle dynamics control* Wenliang Zhang, KTH

Presentation 6: *Braking Distance Minimization on Roads with Varying Friction* Ektor Karyotakis, Volvo Cars and Chalmers

Presentation 7a: *KTH, Vehicle engineering Master programme* Mikael Nybacka, KTH

Presentation 7b: *Chalmers, Mobility engineering Master programme* Dag Bergsjö, Chalmers

Presentation 7c: *LiU, Vehicle engineering courses* Jan Åslund, LiU

Poster 1: *Reversing A-double using steerable axle on the last semi-trailer* Pavan Kumar Adiga Nagaraj, Niveditha Krishnakumar, Chalmers and Volvo Trucks

Poster 2: *Onboard Estimation of Center of Gravity in Heavy Vehicles* Alfred Aronsson and Fabian Fagerlind, Chalmers and Volvo Trucks

Poster 3: *Development and validation of a friction estimation model for collision avoidance maneuvers in autonomous trucks* Ganapati Girish Kamat, Chalmers and Scania

Poster 4: *Physics-Informed Neural Networks for Vehicle Lateral Dynamics Modelling* Rishikesh Vishnu Sivakumar, Yuchuan Dong, Chalmers and Zeekr

Poster 5: *Real time model for predictive axle load estimation* Ajhay Babu Jagadeesan Karthik Babu, Mayank Vijay, KTH and Scania

Note that the pdf file is generated with these “headings as pdf bookmarks”, so you can also navigate via the “bookmark pane” in your pdf reader.

Announcement of the Seminar



Vehicle Dynamics 2025 – Model exchange for virtual pre series

You have already registered for this event.



Vehicle Dynamics 2025 – Model exchange for virtual pre series

👁 568



The seminar has two pages, one with Swedish flag and one with English flag. This is the main page for detailed updates of the announcement and registrations of participation.

Fordonsdynamiksseminarium 2025 – Modell-utbyte för virtuella försör...

Date And Time

May 7, 2025 09:00 AM to
May 7, 2025 04:15 PM

Registration End Date

May 8, 2025

Location

Vera Sandbergs Allé 8, Göteborg.
Plus code from google maps:
MXVG+85 Göteborg

Vehicle Dynamics 2025 – Model exchange for virtual pre series

Vehicle development increasingly utilizes models and simulations to reduce the dependency on building real world prototypes. One can compare the A-, B-, and C-samples for real pre-series with exchange of models of vehicular sub-systems to a complete vehicle model. Such model exchange requires compatibility between model formats, which is a problem since one cannot expect all vehicle manufacturers and system suppliers to ever use the same format. For exchangeability, one would need acausal physical interfaces, well-defined model parameters, and signal interfaces. One would also need model integrating engineers, corresponding to real prototype workshops.

The presentations and poster this year are not all focusing model exchange, but we have asked these to address model exchange as one aspect of their topic.

Wednesday 7 May

The seminar will be in "hybrid format", meaning that participation is possible both in-real-life and on-line.

In-real-life:

Room Vasa C, Chalmers, Campus Johanneberg, Vera Sandbergs Allé 8, Göteborg

Plus code from google maps: MXVG+85 Göteborg

On-line:

Link to on-line meeting will be sent to those who register as on-line.

Registration

Registration is made via https://www.sveafordon.com/en/?post_type=event_listing&p=4926&preview=true.

If you are member, it is easier to register if you log in before registration.

You will get a confirmation that you are registered.

Initial registration deadline is 2025-05-05, we will order light lunch and fika for those registered until then plus some in reserve.

We will re-open the registration after that and for those who register after this, we cannot promise light lunch and fika.

2025-05-06: Registration is now re-opened, new deadline 2025-05-08 (=day AFTER seminar). If you register for on-line participation and very late, I might miss to send out on-line link to you. For those (few?) please

are, I might miss to send out the link to you. For those (if any) please give me an SMS or call at +46 70 3821383 and I will try to send you link.

Seminar costs

The seminar is free for SVEA members. SVEA will sponsor food (fika and light lunch) for members (incl. pending membership applicants) who attend in-real-life.

For non-members attending in-real-life there will be a fee of 210 SEK (>membership fee).

Presenters (incl. poster presenters) attend for free.

We encourage to apply for SVEA membership (<https://www.sveaforndon.com/en/for-members/register/>). SVEA membership fee is 200 SEK/year (junior 0 SEK, senior 100 SEK).

Purpose with the seminar

- Present and discuss interesting issues within and challenges for *Model exchange for virtual pre series*
- Create understanding and interest for vehicle dynamics
- Develop, increase, and spread competence
- Networking between engineers, organisations, and students

SVEAs objectives

- To make vehicular technology's voice heard in an increasingly more challenging debate among different vehicle types and transport modes both domestic and globally
- To build a network for efficient distribution of technological information
- To attract the next generation of Swedish vehicular engineers

Poster exhibition

There will be an exhibition of posters. It can be, e.g., master theses or PhD theses, either concluded or almost concluded. Please contact Lars Drugge larsd@kth.se or Bengt Jacobson bengt.jacobson@chalmers.se if you would like to propose a poster.

Each poster presenter should do a poster and a "micro presentation" with a few slides. Then the presenter should also be available for questions at the poster stands.

Proceedings

There will be proceedings from the seminar. This means that the presenters, including poster presenters, are welcome with a paper, or at least a public version of their presentation material. The proceedings will be published on the SVEA web. It will include a list of seminar participants, unless you ask us to not list your name.

Agenda

09:00-09:45	Coffee and registration	
09:45-09:55	Welcome	Matthijs Klomp (Moderator), Bengt Jacobson (SVEA, VDCA)
09:05-11:00	Session 1: Presentations (20+10 min each):	
	Pres1: <i>FMU factory from CAE to SAE</i>	Edo Drenth, Volvo Autonomous Solutions
	Pres2: <i>Dynamic simulation and beyond</i>	Peter Sundström, Modelon
11:00-11:05	Short break	
11:05-12:00	Session 2: Presentations (20+10 min each):	
	Pres 3: <i>Target Cascading from Full Vehicle Dynamics Targets to System & Subsystem Vehicle Requirements</i>	Axel Villandseie, Volvo Cars
	Micro presentations of posters (5 min each):	
	Post1: <i>Reversing A-double using steerable axle on the last semi-trailer</i>	Pavan Kumar Adiga Nagaraj, Niveditha Krishnakumar, Chalmers, Volvo Trucks
	Post2: <i>Onboard Estimation of Center of Gravity in Heavy Vehicles</i>	Alfred Aronsson and Fabian Fagerlind, Chalmers and Volvo Trucks
	Post3: <i>Development and validation of a friction estimation model for collision avoidance maneuvers in autonomous trucks</i>	Ganapati Girish Kamat, Chalmers, Scania
	Post4: <i>Physics-Informed Neural Networks for Vehicle Lateral Dynamics Modelling</i>	Rishikesh Vishnu Sivakumar, Yuchuan Dong, Chalmers and Zeekr
	Post5: <i>Real time model for predictive axle load estimation</i>	Ajhay Babu Jagadeesan Karthik Babu, Mayank Vijay, KTH and Scania
12:00-13:30	Light lunch with networking and manned posters in seminar room.	
13:30-14:30	Session 3: Presentations (20+10 min each):	
	Pres 4: <i>about rolling resistance on roads with various weather and surface condition</i>	Mikael Askerdal, Volvo LV och Chalmers
	Pres 5: <i>FMU-based co-simulation for autonomous vehicle dynamics control</i>	Wenliang Zhang, KTH
14:30-15:00	Coffee with networking and manned posters	
	Session 4: Presentations (20+10 min each):	
	Pres 6: <i>Real-time Disturbance</i>	

15:00-16:00	Pres 6: <i>Braking Distance Minimization on Roads with Varying Friction</i>	Ektor Karyotakis, Volvo Cars and Chalmers
	Pres 7: Swedish vehicle engineering education:	
	Pres 7a: <i>KTH, Vehicle engineering</i> Pres 7b: <i>Chalmers, Mobility engineering</i> Pres 7c: <i>LiU, Vehicle engineering courses</i> Discussion	Mikael Nybacka, KTH Dag Henrik Bergsjö, Chalmers Jan Åslund, LiU All
16:00-16:15	Wrap-up <ul style="list-style-type: none"> · Overall technical questions from today's presentations and posters? · Feedback on present years seminar. Proposals for next year's seminar. · Discussion on other 	

The seminar is arranged by the Swedish Vehicle Dynamics Competence Area (VDCA) and Swedish Vehicular Engineering Association (SVEA). The seminar is arranged with VDCA representatives from:

AFRY Automotive
 AstaZero
 Chalmers
 KTH
 LiU
 Polestar
 Scania
 Volvo Cars
 Volvo Trucks
 VTI
 Zeekr Technology Europe

VDCA Swedish Vehicle Dynamics Competence Area



SVEA is the society member for Sweden in FISITA:



Do not hesitate to contact us

with questions and suggestions to

info@sveafordon.com

Swedish Vehicular Engineering Association

Participations

51 participants

Name	Affiliation	e-mail
Abhijeet Behera	VTI	abhijeet.behera@vti.se
Ajhay Babu Jagadeesan Karthik Babu	KTH and Scania	abjkb@kth.se
Albin Gröndahl	Zeekr	albin.grondahl1@zeekrtech.eu
Axel Villandseie	Volvo Cars	Axel.Villandseie@volvocars.com
Bengt J H Jacobson	Chalmers	bengt.jacobson@chalmers.se
Carl Emvin	Chalmers	Carl.Emvin@chalmers.se
Carl Stålfors	Scania	carl.stalfors@scania.com
Chaojie Lu	Scania	chaojie.alex@outlook.com
Dag Henrik Bergsjö	Chalmers	dagb@chalmers.se
Dang Lu	Jilin University	ludang@jlu.edu.cn
Daniel Korhonen	Scania	daniel.korhonen@scania.com
Dragan	University of Belgrade	dragan.sekulic@chalmers.se
Edo Drenth	Volvo Autonomous Solutions	edo.drenth@volvo.com
Egbert Bakker	former Volvo Cars	ebakker@bahnhof.se
Ektor Karyotakis	Volvo Cars and Chalmers	ektor.karyotakis@volvocars.com
Fredrik Bruzelius	Chalmers	Fredrik.Bruzelius@chalmers.se
Ganapati Girish Kamat	Chalmers and Scania	ganapati.g.kamat@gmail.com
Ilhan Yunus	VCC and KTH	ilhan.yunus@volvocars.com
Ingemar Johansson	former Chalmers, CEVT, Lotus, etc.	ingemarj55@gmail.com
Isuru Samuddha Lanka Ranasinghege	Chalmers	isuruapplication@gmail.com
Jan Åslund	LiU	jan.aslund@liu.se
Jiaming Gao	Zeekr	jiaming.gao3@zeekrtech.eu
Jolle Ijkema	Scania	jolle.ijkema@scania.com
Karthik Manchanahalli Rajendra Prasad	karthikmr29@gmail.com	karthikmr29@gmail.com
Kenneth Ekström	Volvo Cars	kenneth.ekstrom@volvocars.com
Lars Drugge	KTH	larsd@kth.se
Markus Agebro	Scania	markus.agebro@scania.com
Mathias Lidberg	Fraunhofer	mathias.lidberg@fcc.chalmers.se
Mathias Strandberg	Modelon	mathias.strandberg@modelon.com
Mats Jonasson	Chalmers	mats.jonasson@chalmers.se
Matthijs Klomp	VCC and Chalmers	matthijs.klomp@volvocars.com
Mayank Vijay	KTH and Scania	mayankv@kth.se
Mikael Askerdal	Volvo Trucks and Chalmers	mikael.askerdal@volvo.com
Mikael Nybacka	KTH	mnybacka@kth.se
Niveditha Krishnakumar	Volvo Trucks and Chalmers	niveditha.krishnakumar@volvo.com
Pavan Kumar Adiga Nagaraj	Chalmers and Volvo Trucks	pavan.kumar.adiga.nagaraj.2@volvo.com

Name	Affiliation	e-mail
Peter Nilsson	Volvo Autonomous Solutions	peter.q.nilsson@volvo.com
Peter Sundström	Modelon	peter.sundstrom@modelon.com
Reno Filla	Scania	reno.filla@scania.com
Rishikesh Vishnu Sivakumar	Chalmers and Zeekr	rishikesh.sivakumar@zeekrtech.eu
Rohan Kumaar Vasudevan	Chalmers	rohankumaar15@gmail.com
Sachin Janardhanan	Volvo Trucks and Chalmers	sachin.janardhanan@volvo.com
Thomas Camén	AFRY	tomas.camen@afry.com
Umur Erdinc	Volvo Trucks and Chalmers	umur.erdinc@volvo.com
Utsav Khan	Zeekr	utsav.khan@gmail.com
Vivekanandan Madhuravasal Narasimhan		vivekmn30@gmail.com
Wenliang Zhang	KTH	zhang.wenliang@outlook.com
Yanru Suo	Volvo Trucks	yanru.suo@volvo.com
Yuchuan Dong	Chalmers and Zeekr	yuchuan@chalmers.se
Zhaohui Ge	Chalmers	zhaohui.ge@chalmers.se
Ömur Can Kayaokay	Scania	omur.can.kayaokay@scania.com
Abhijeet Behera	VTI	abhijeet.behera@vti.se
Ajhay Babu Jagadeesan Karthik Babu	KTH and Scania	abjkb@kth.se

Introduction to the seminar

VDCA *Swedish Vehicle Dynamics Competence Area*

VEA SWEDISH
VEHICULAR
ENGINEERING
ASSOCIATION
SVERIGES FORDONSTEKNISKA FÖRENING



FISITA



Introduction to
Vehicle Dynamics Seminar 2025
Model exchange for virtual pre series

Wednesday 2024-05-07 hosted by Chalmers, Göteborg, Sweden

About this year's seminar topic

- **Model exchange for virtual pre series**
- System suppliers deliver virtual A-, B-, C-samples to automotive developers
- Automotive developers compile the samples to complete vehicle models, “virtual pre-series”
- How to handle portability between the submodels? Challenges:
 - Parameterisation,
 - physical connections, and
 - signal connections
 - (Version management, over development time and different use)

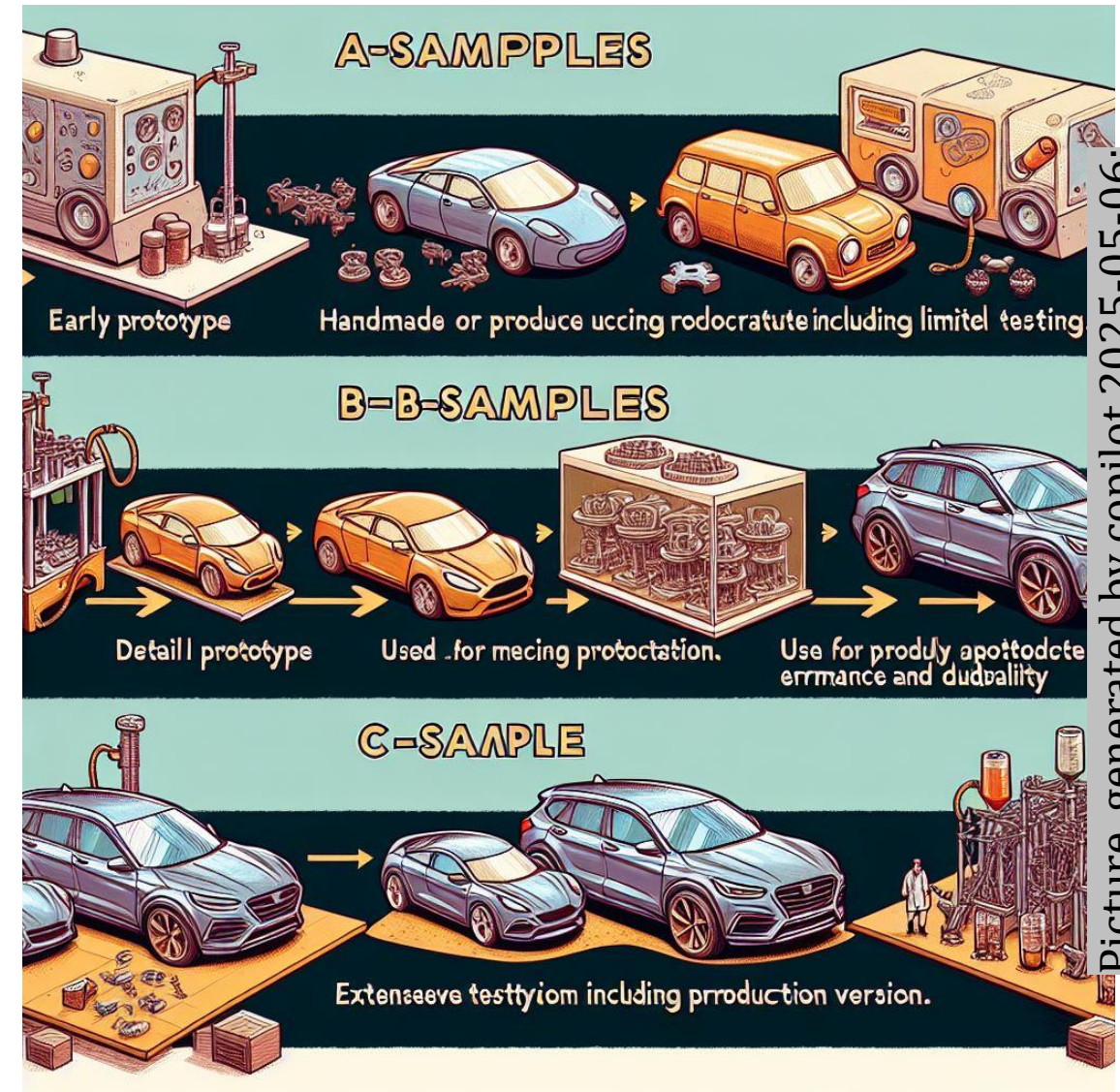

Picture generated by copilot 2025-05-06:

Purpose with the seminar

- **Present and discuss** interesting issues within and challenges for Vehicle Dynamics within a topic which is selected each year
- Create **understanding and interest** for vehicle dynamics
- Develop, increase, and spread **competence**
- **Networking** between engineers, organisations, and students

Arrangement of the seminar

- Annual since 2013
- Arranged by **VDCA**,
 - which is a workgroup in **SVEA**
 - which is Sweden's "society member" in **FISITA**



SVEAs objectives

- To make **vehicular technology's voice heard** in an increasingly more challenging debate among different vehicle types and transport modes both domestic and globally
- To build a **network** for efficient distribution of technological information
- To attract the **next generation of Swedish vehicular engineers**

What have we achieved with our seminars

Year	Topic	Location
2013	Vehicle Dynamics Challenges	Lindholmen, Göteborg
2014	Vehicle Dynamics in a Cooperative Environment	Scania, Södertälje
2015	Vehicle Dynamics for Energy Efficient Mobility	Chalmers, Göteborg
2016	Functional Architectures and Virtual Methods for Efficient Vehicle Dynamics Development	NEVS, Trollhättan
2017	Vehicle Dynamics for Automated Driving	Scania, Södertälje
2018	Model Fidelity for Vehicle Motion Predictions	Chalmers, Göteborg
2019	<replaced by IAVSD international conference>	Göteborg
2020	<cancelled>	Cancelled, due to pandemic
2021	Future Mobility ...and not only Lateral	Online, due to pandemic
2022	Connected and Electric	KTH, Stockholm and on-line
2023	Testing, development, and verification	AstaZero, Sandhult and on-line
2024	Virtual verification	Linköping and on-line
2025	Model exchange for virtual pre series	Göteborg, Chalmers and on-line
2026	(to be discussed at the wrap-up of 2025's seminar)	

About VDCA

VDCA *Swedish Vehicle Dynamics Competence Area*

VDCA “core group” has representatives and contributions from vehicle manufacturers, university groups in the subject Vehicle Dynamics, and VTI:

AFRY Automotive

AstaZero

Chalmers

KTH

LiU

Polestar

Scania

Volvo Cars

Volvo Trucks

VTI

Zeekr Technology Europe

Let's enjoy the day and do networking

Presentation 1:
Dynamic simulation and beyond
Peter Sundström, Modelon

Dynamic simulation and beyond



Modelon

Peter Sundström

Dynamic Simulation

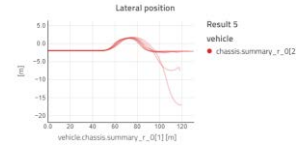

Steady State Analysis

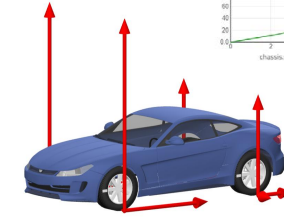
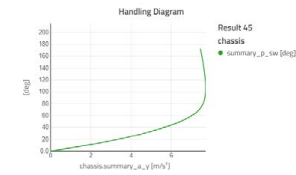

Frequency Analysis

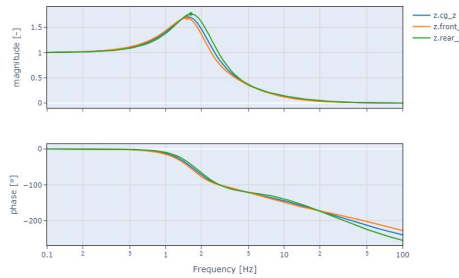

Optimization

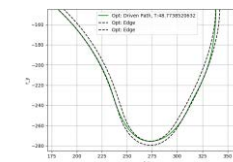
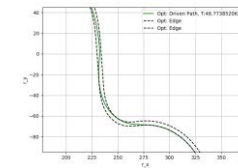
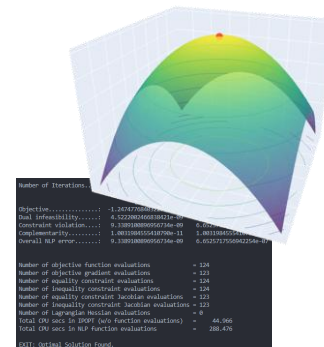

Frequency Analysis

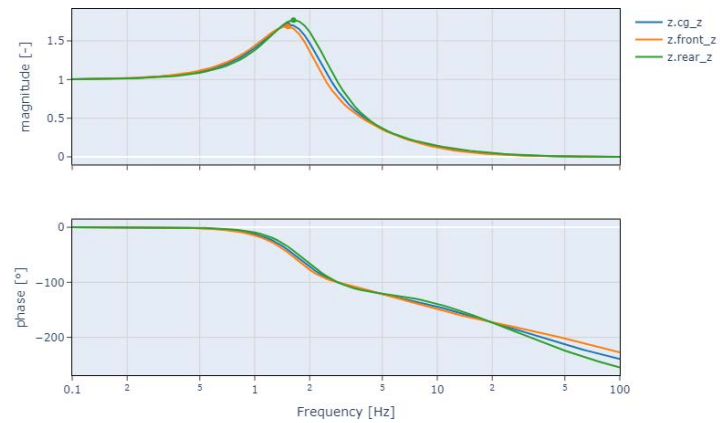

Frequency Analysis

Vertical inputs at each wheel
Outputs at front, rear and c.g.

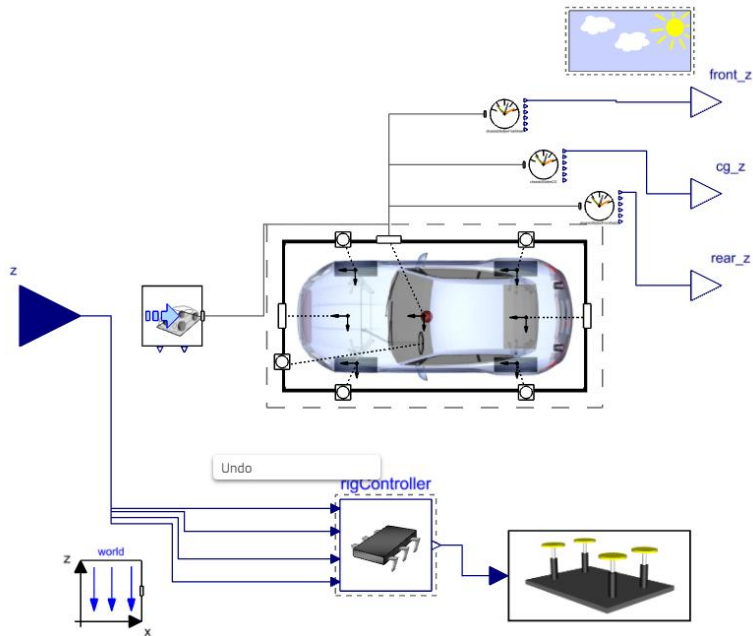

Vertical output at cg, response to uniform vertical input at wheels
Sweep total vehicle mass

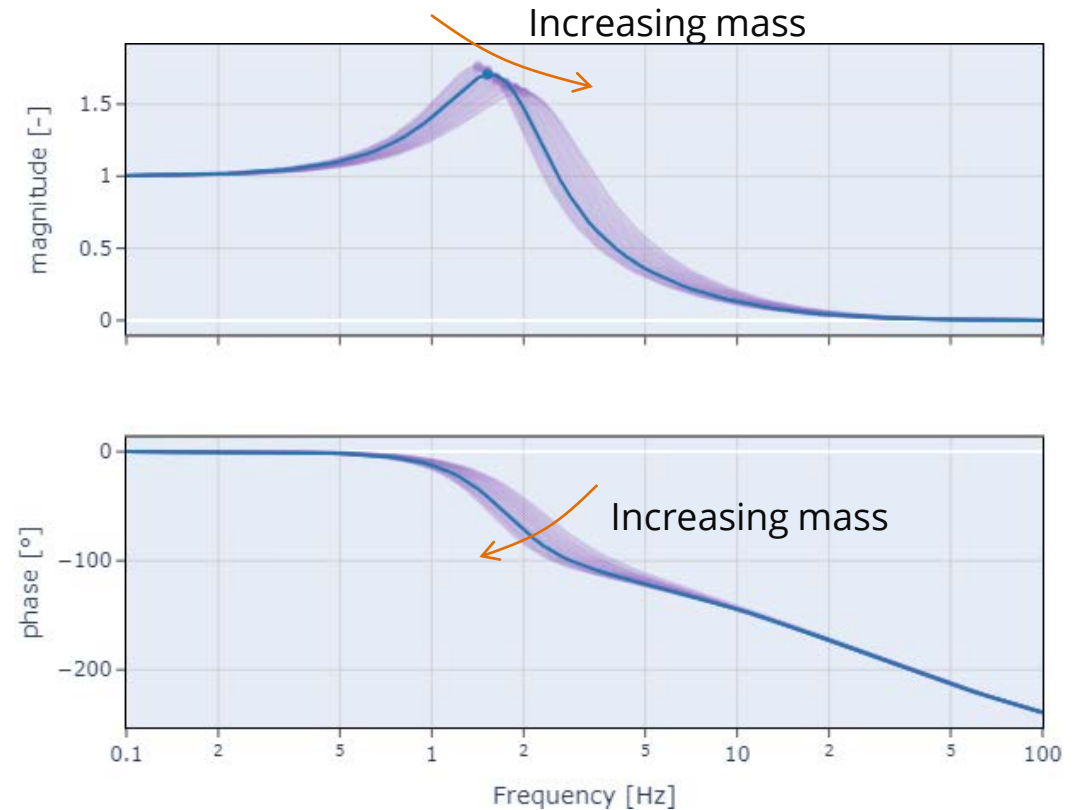

Steady State Analysis

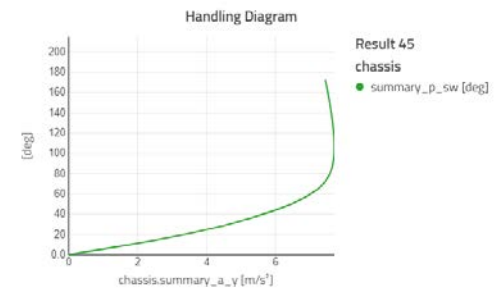
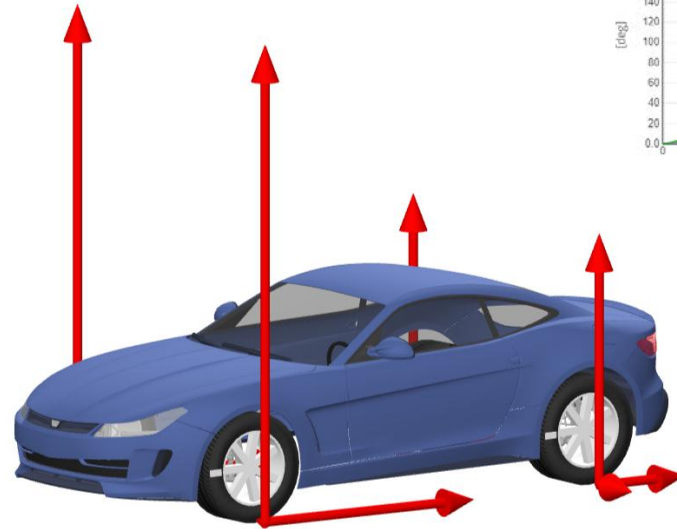

$$\dot{x} = 0$$

Steady State Analysis

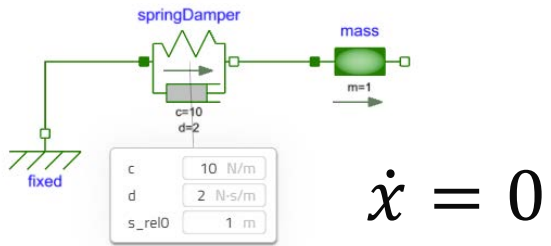

Run dynamic sim until steady-state is reached

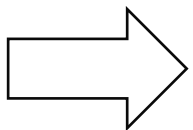

Add equations for steady state

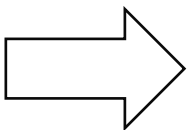

Use external solver to solve dynamic model for steady state x such that $der(x)=0$

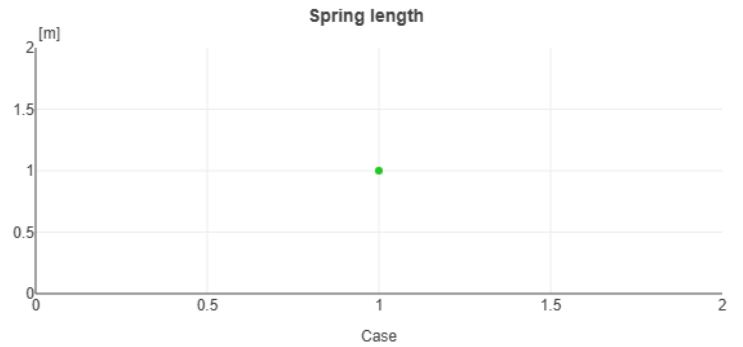
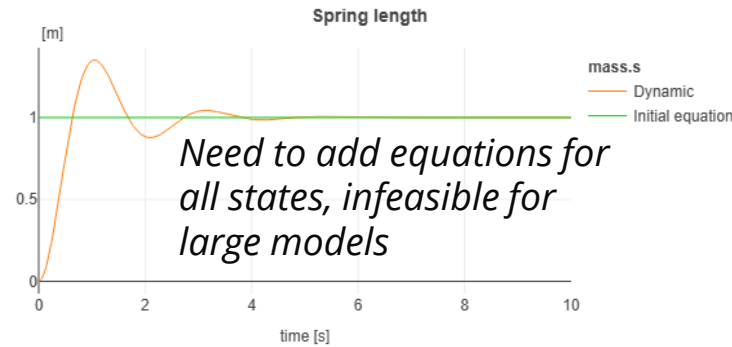
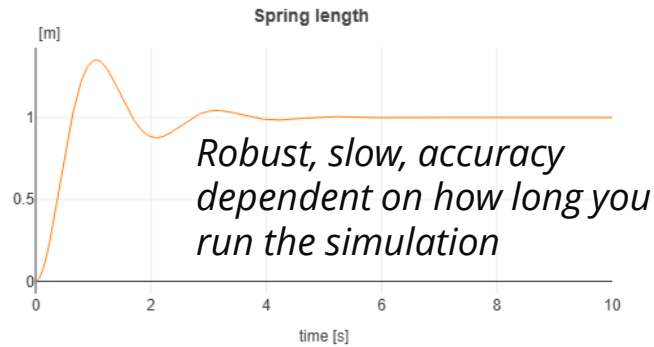

Suspension Analysis

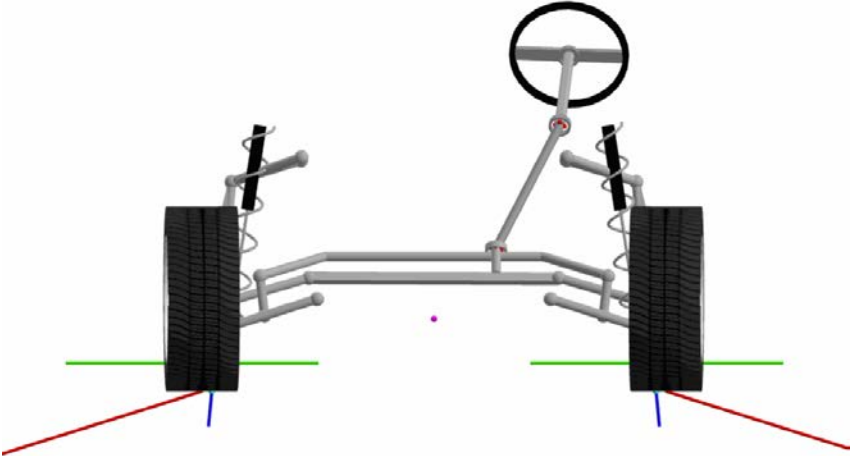
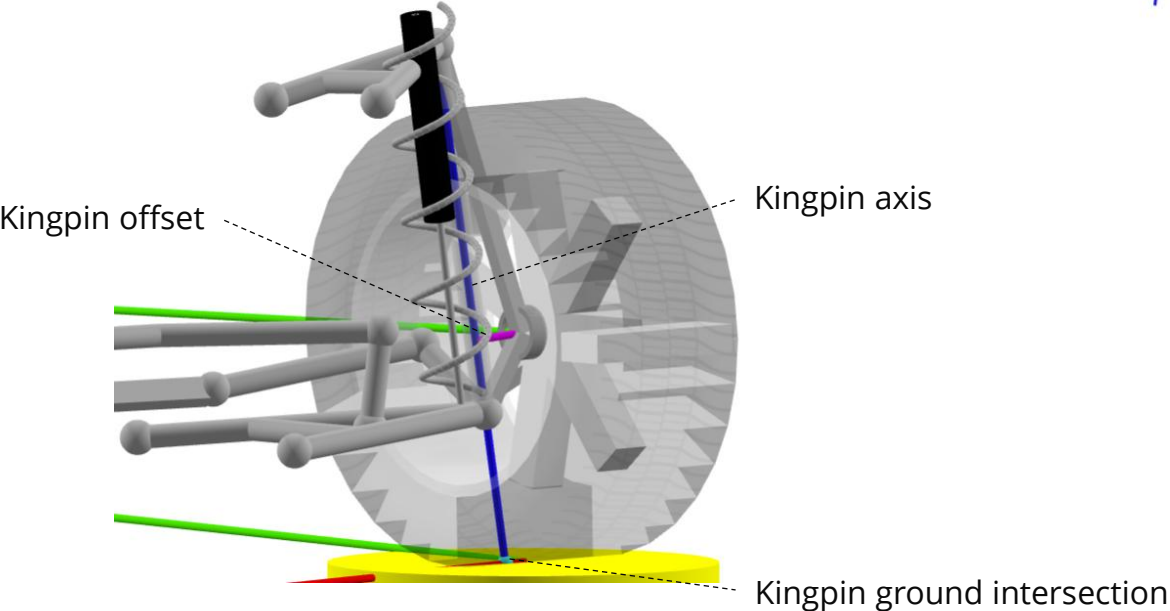
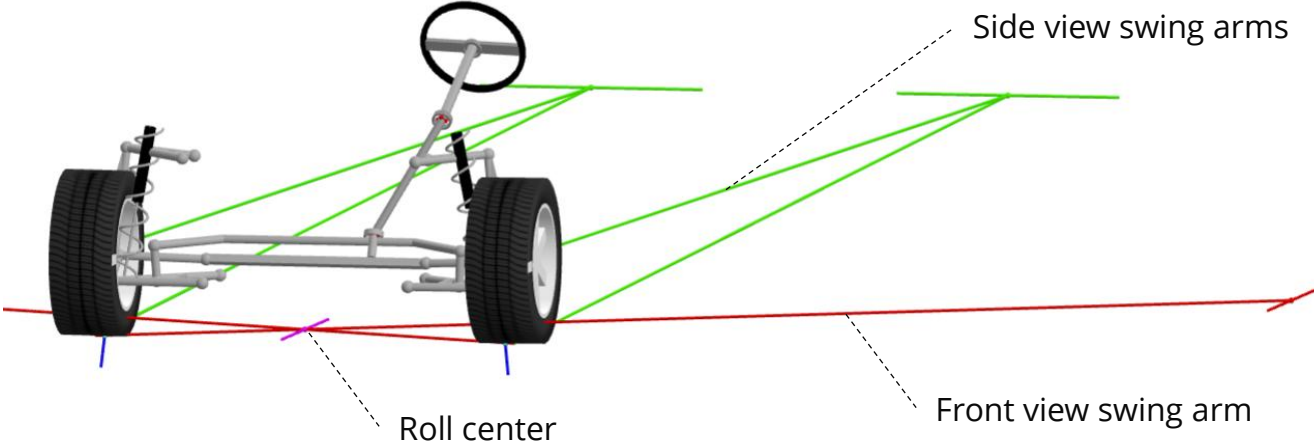

Chassis Analysis

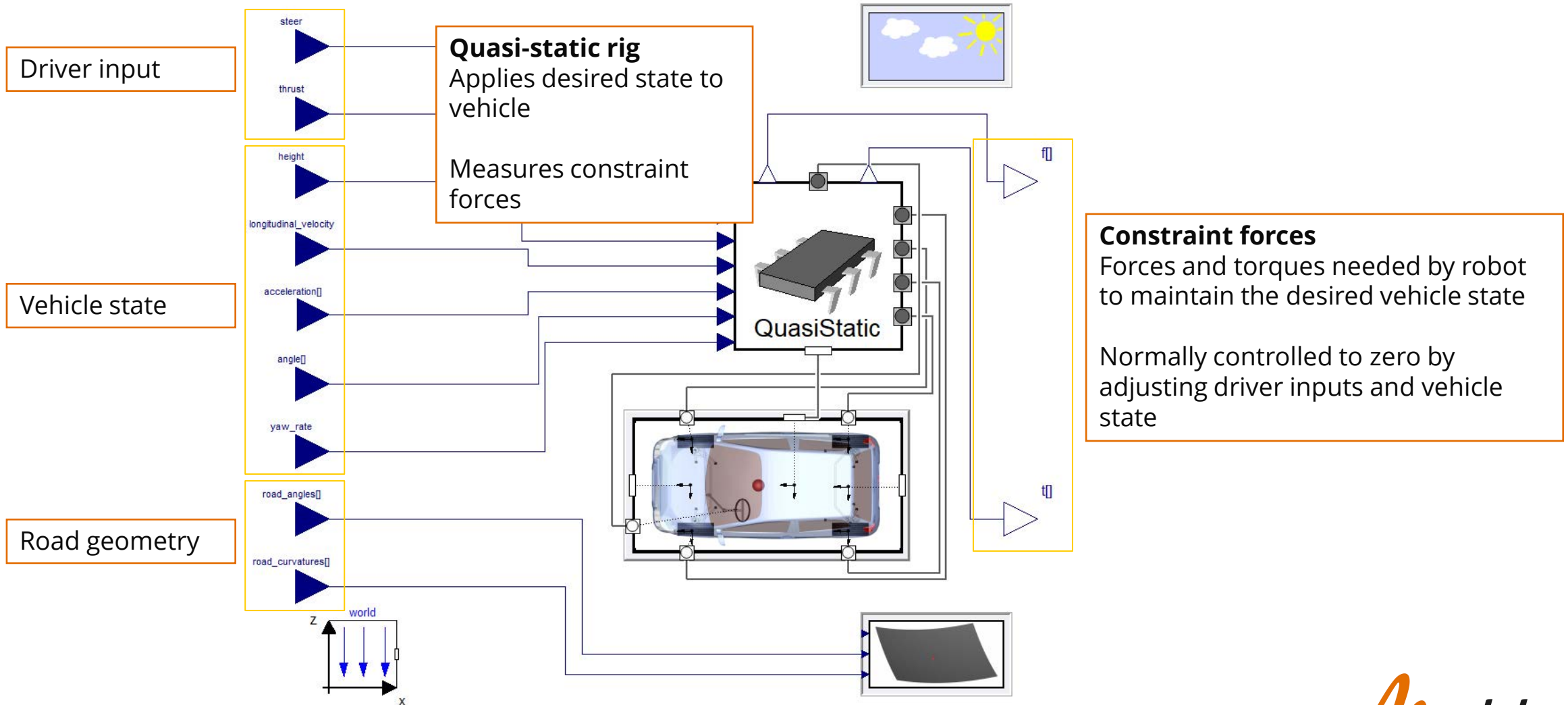

Chassis Analysis

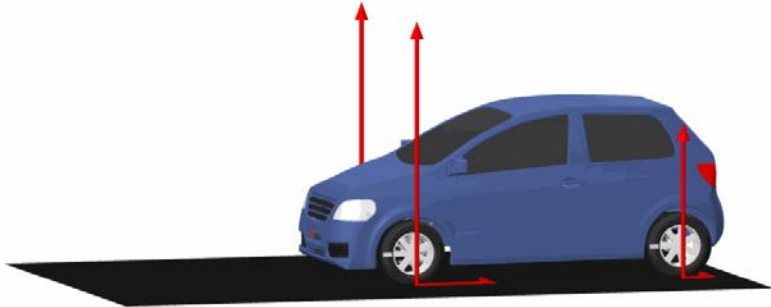
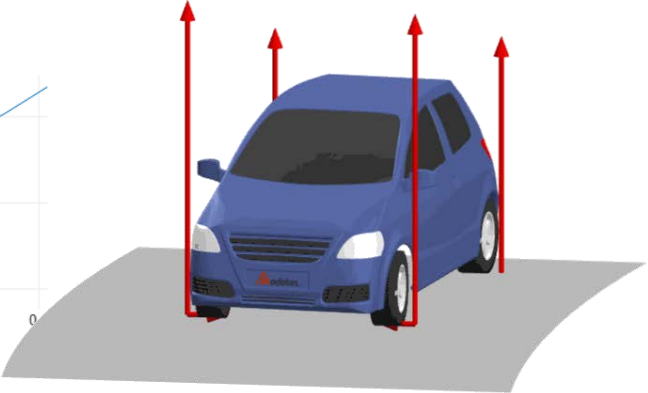
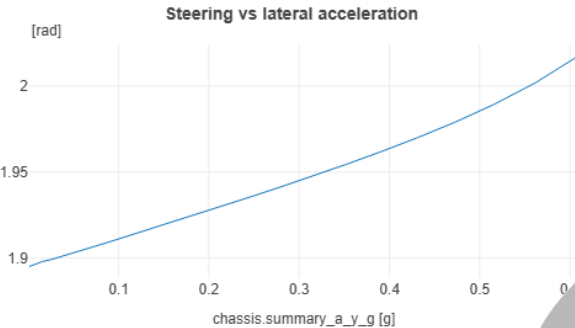
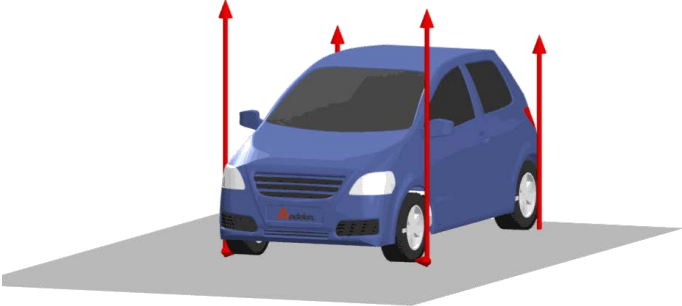
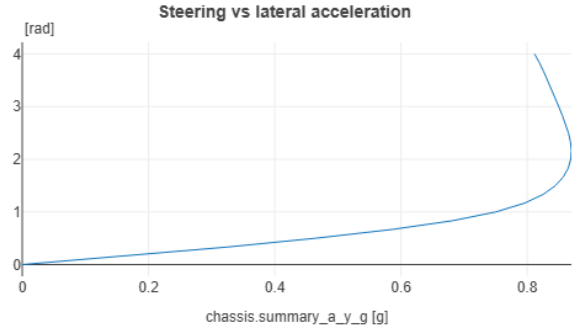

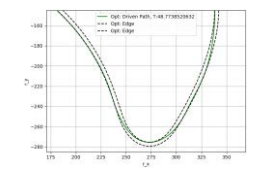
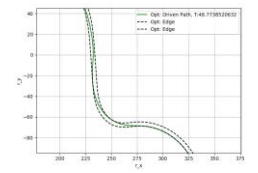
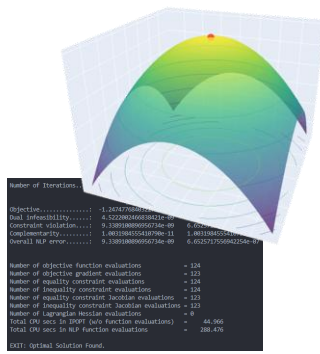

Optimization

Optimization

Derivative free optimization

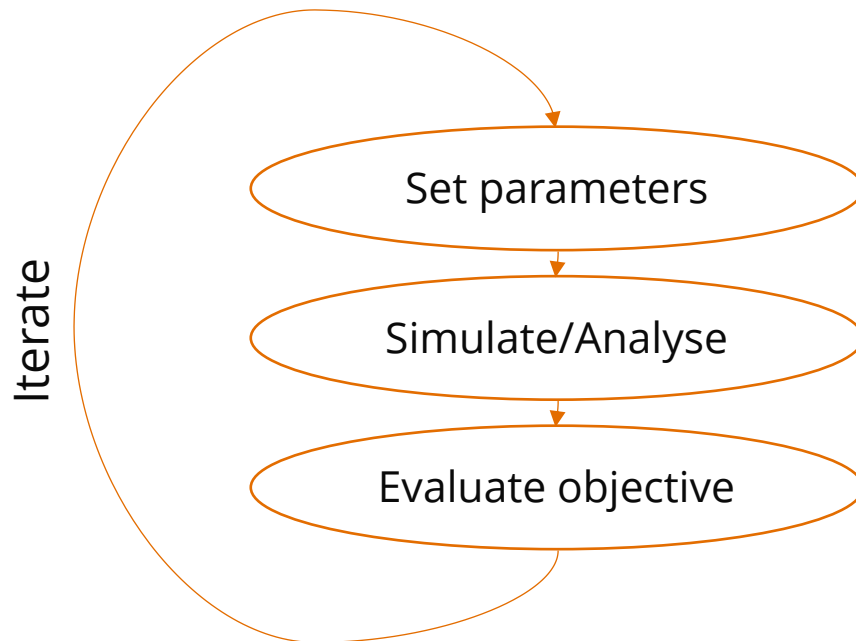

Gradient based/Trajectory optimization

Optimize trajectories using collocation

Need first and second order derivatives from inputs -> objective and constraints

Divide into time segments, optimize objective such that segments line up and constraints are fulfilled

Derivative free optimization

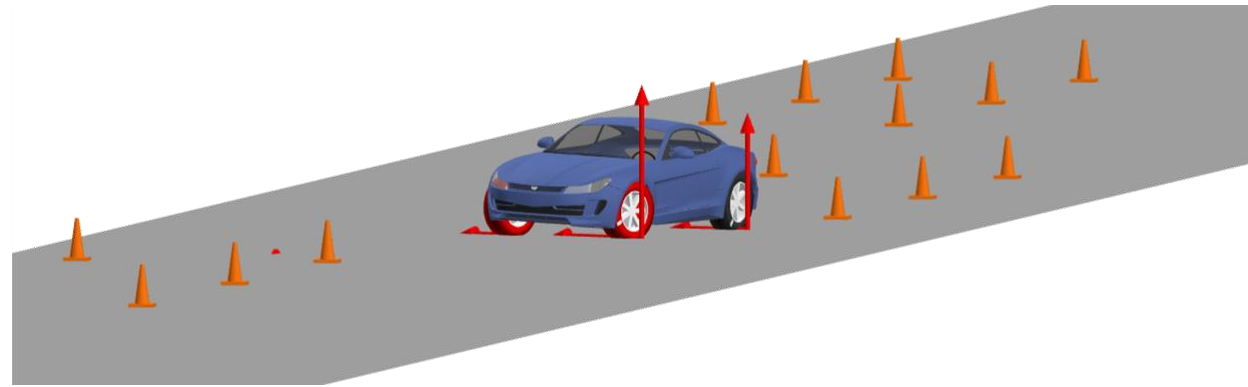
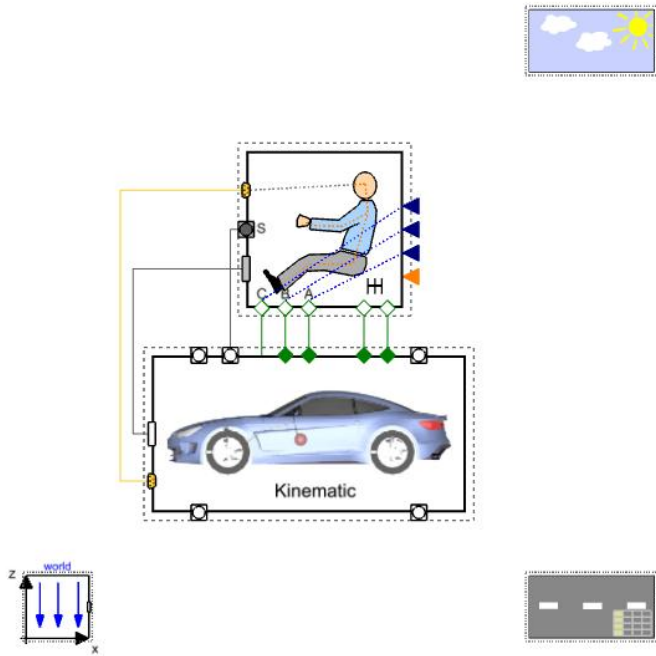

Driver model follows prescribed path
Condition to stay within cones

Use optimization algorithm (Nelder-Mead implementation in SciPy) to find highest initial velocity that doesn't violate constraints

For <5 parameters, this is robust and can handle many types of models, though it's not very fast

Trajectory optimization with Optimica and CasADi

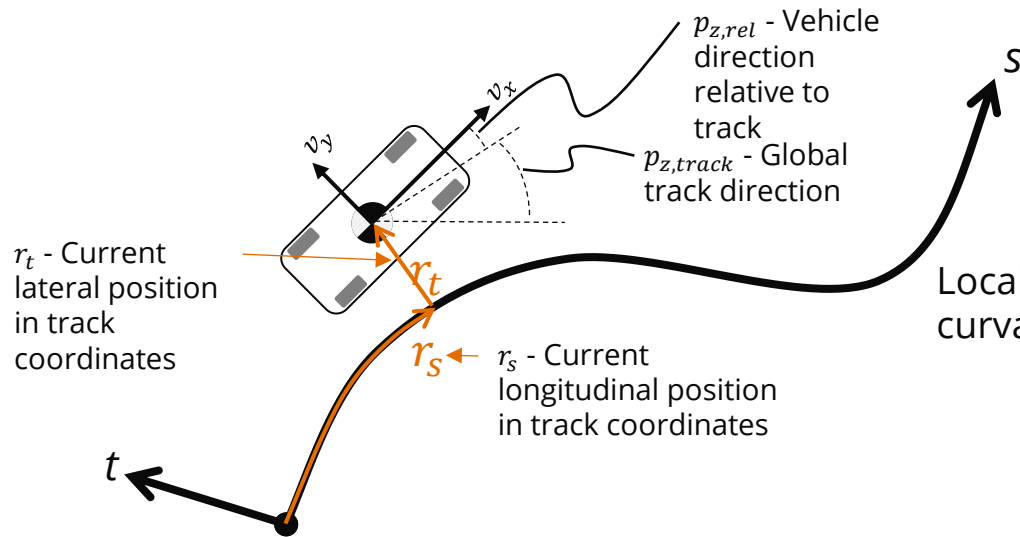

Local track coordinate system based on curvature and distance along track

Simple optimization formulation, cost on lap time + small cost on actuator usage

Two-track vehicle model with combined slip and relaxation dynamics
(not multibody based)

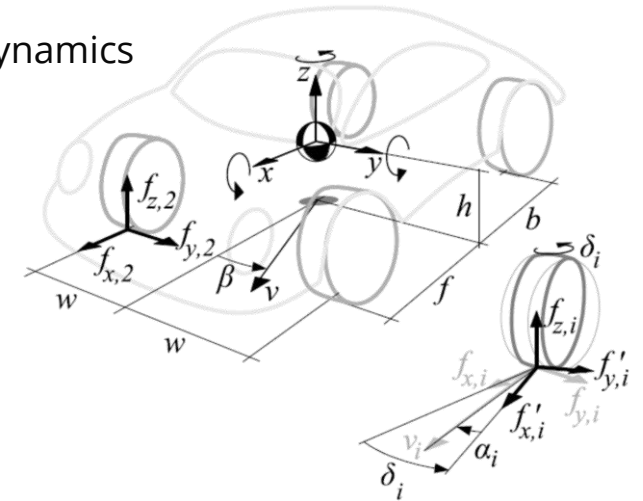

```

optimization LapTimeMinimization(
  objective=100*finalTime+1*icost(finalTime),
  startTime = 0,
  finalTime(free=true,max=160,min=10,initialGuess=122))
  
```

Trajectory optimization with Optimica and CasADi

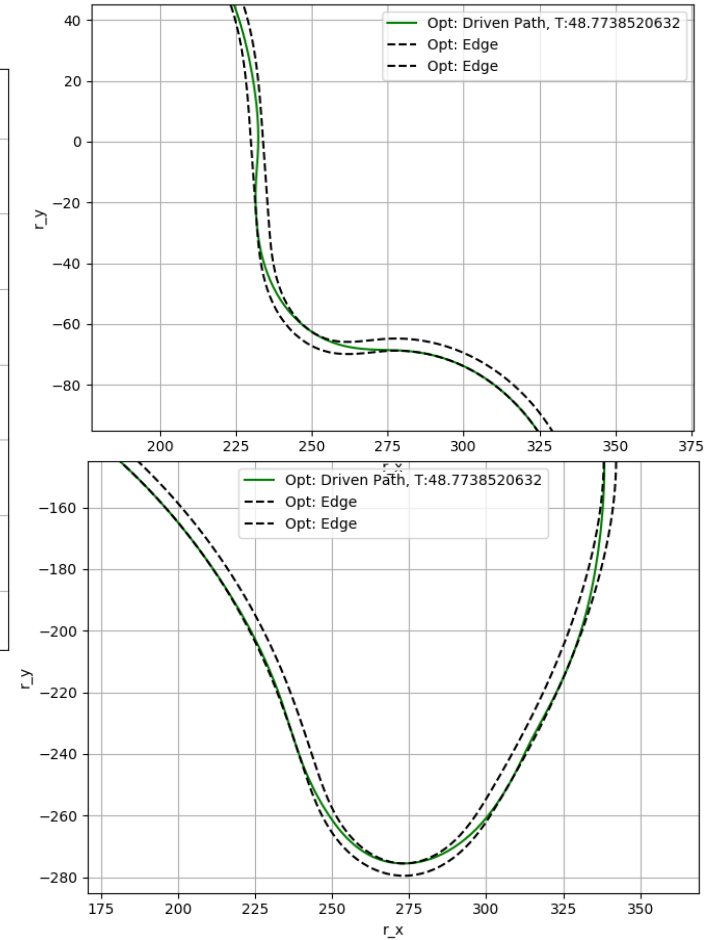
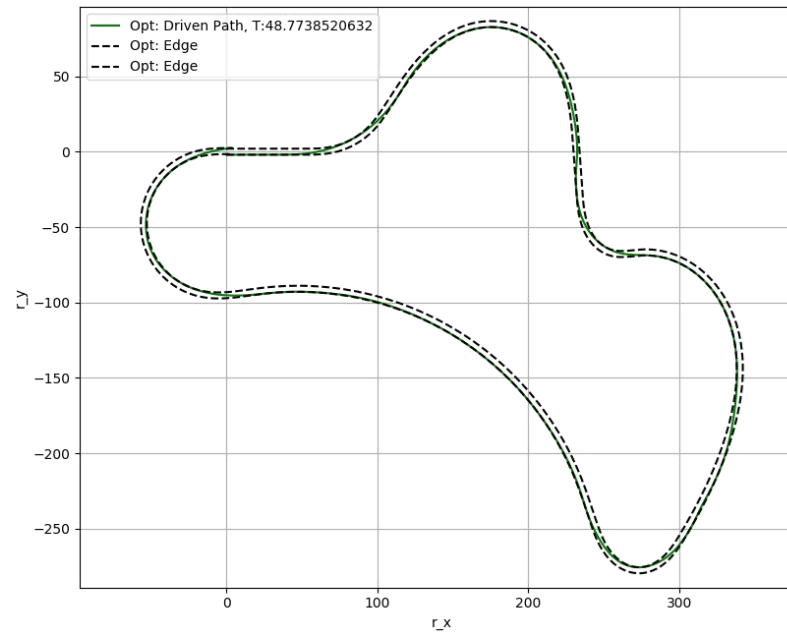
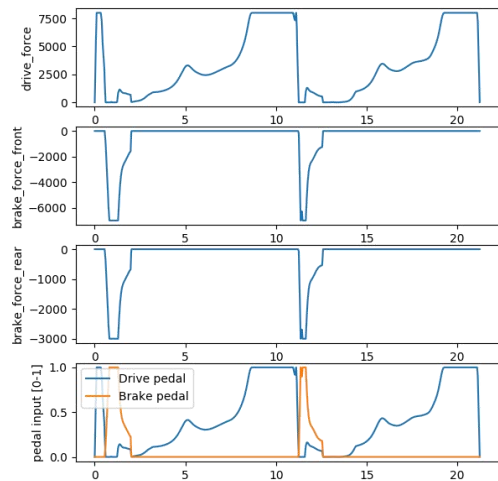
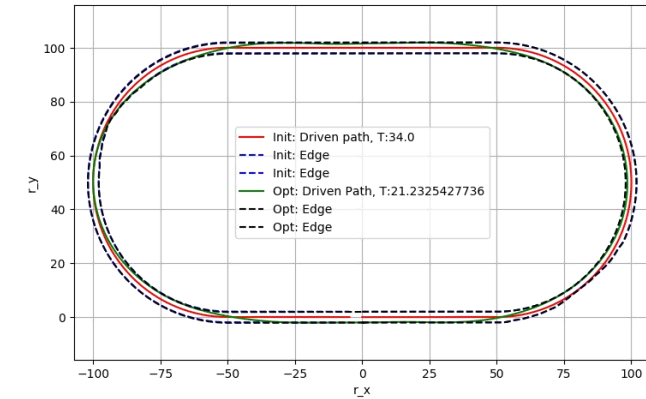

Very capable, but places high demands on model formulation (continuous derivatives, all Modelica constructs are not supported)

Trajectory optimization with Pyomo

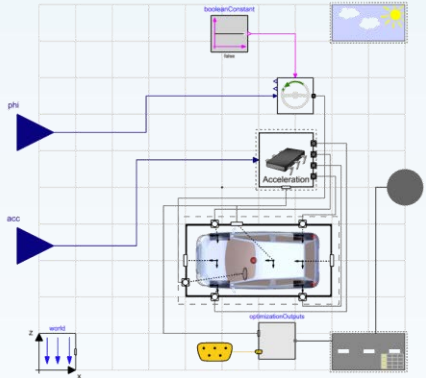
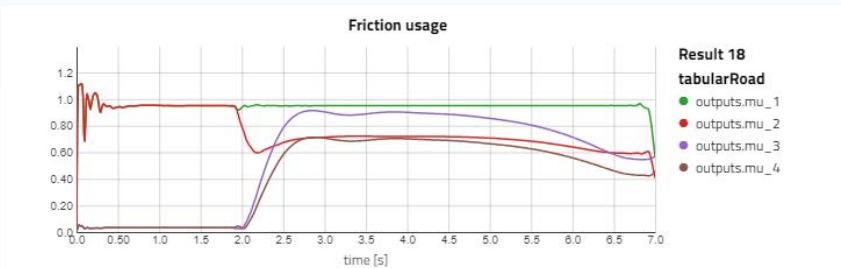
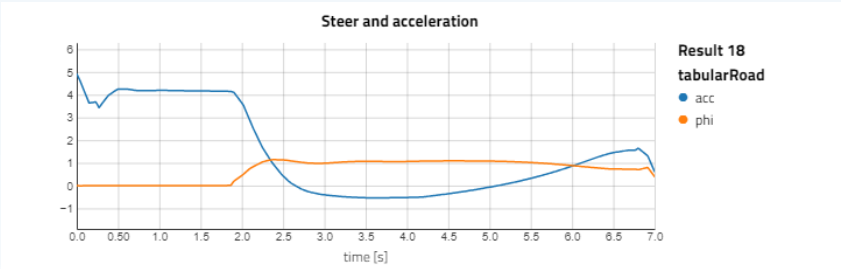

```

Number of Iterations.....: 122
Objective.....: (scaled) (unscaled)
Dual infeasibility.....: 4.5222802466838421e-09 4.5222802466838421e-09
Constraint violation.....: 9.3389100896956734e-09 6.6525717556942254e-07
Complementarity.....: 1.0031984555410790e-11 1.0031984555410790e-11
Overall NLP error.....: 9.3389100896956734e-09 6.6525717556942254e-07

Number of objective function evaluations = 124
Number of objective gradient evaluations = 123
Number of equality constraint evaluations = 124
Number of inequality constraint evaluations = 124
Number of equality constraint Jacobian evaluations = 123
Number of inequality constraint Jacobian evaluations = 123
Number of Lagrangian Hessian evaluations = 0
Total CPU secs in IPOPT (w/o function evaluations) = 44.966
Total CPU secs in NLP function evaluations = 288.476

EXIT: Optimal Solution Found.
    
```

Early development, FMU based workflow allows more types of models to be used at the cost of optimization performance

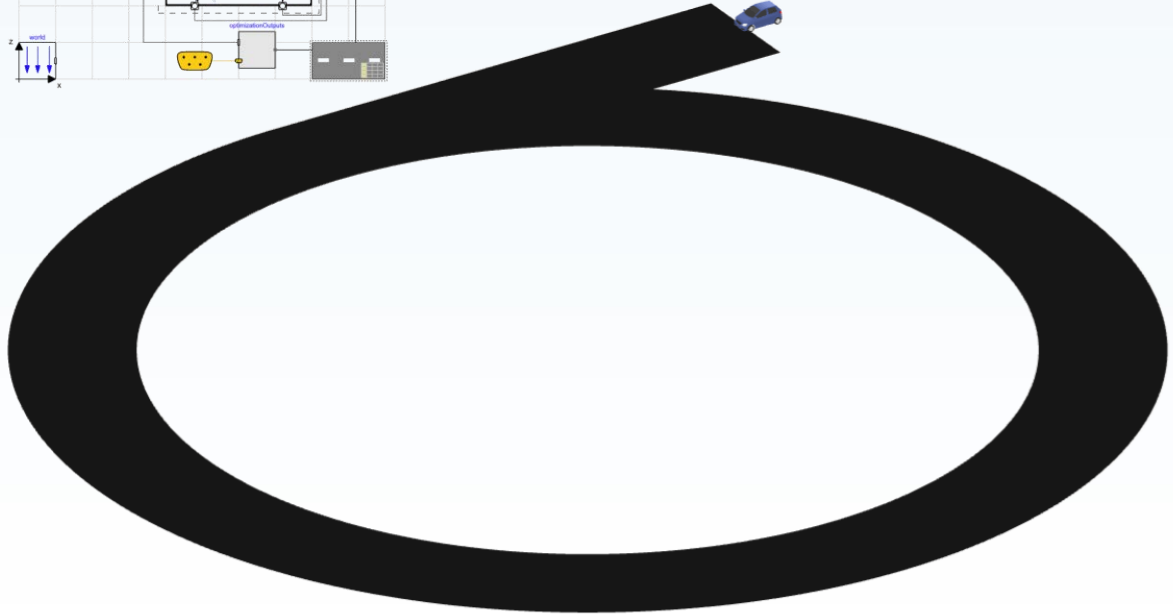

Dynamic Simulation

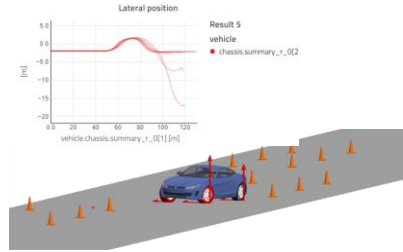

Frequency Analysis

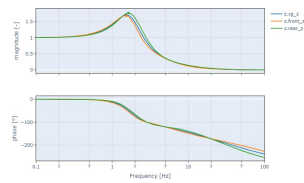

Steady State Analysis

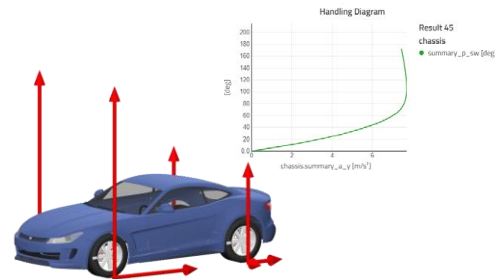

Optimization

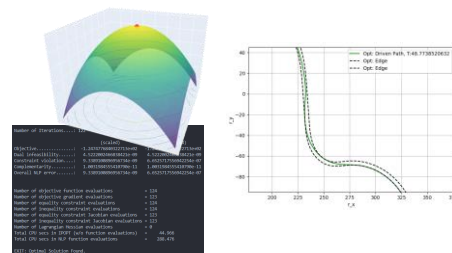

Modelon Impact



Accurate Simulations. Better Decisions.

Presentation 2:

FMU factory from CAE to SAE

Edo Drenth, Volvo Autonomous Solutions

V O L V O

FROM COMPUTER- TO SOFTWARE AIDED ENGINEERING

Quality, Traceability, and Speed

Volvo Autonomous Solutions

Vehicle Domain | Vehicle Models Team | Internal | ©2025

2025-05-07

The Purposes of Modelling

The promises of simulation

- Cost reduction
 - Reduced number of expensive physical prototypes
 - Cut development time
 - Quicker turn around on design changes
 - Measure the immeasurable
 - All signals are available
 - Create better understanding
- Virtual integration
 - Cost effective integration of multiple embedded systems
 - Virtual regression testing
 - Cost effective scaling for automation

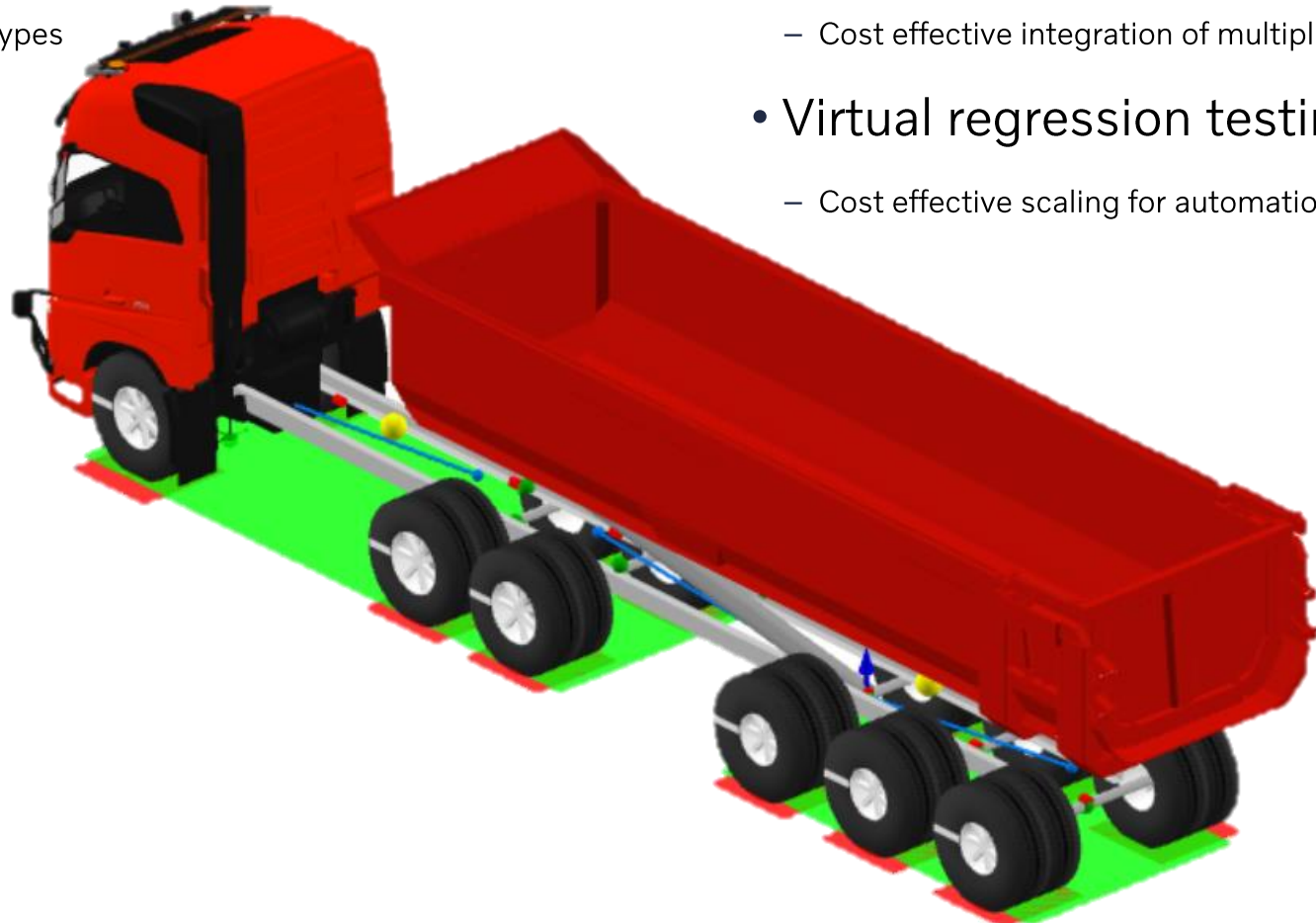

Purpose Driven Model Fidelity

Models may only answer questions you modelled in the first place

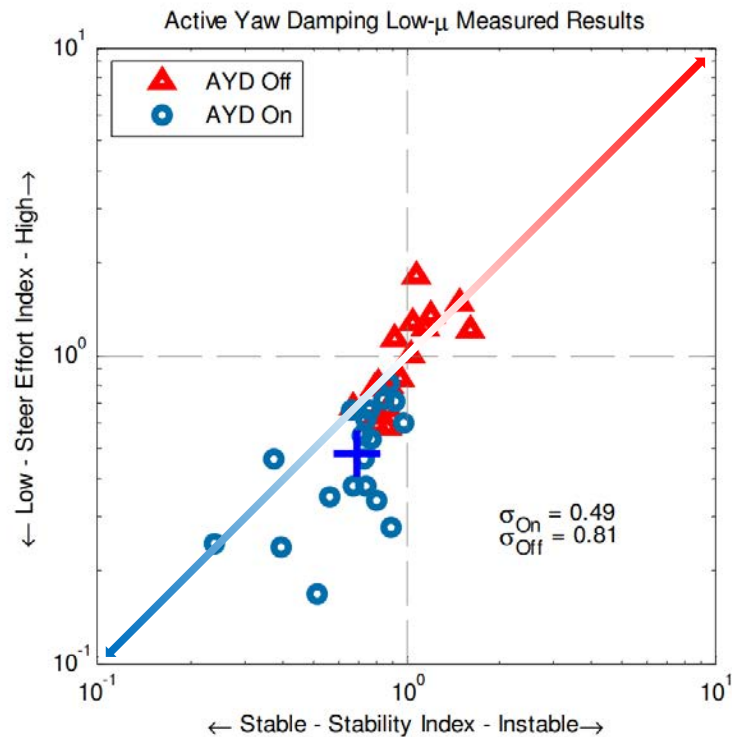

Source: Drenth, Haldex Cross Wheel Drive

“All models are wrong, but some are useful”

- George Box

Systems Engineering

- Verifiable Requirements
- Break down
- Iterations
- Implementation
- Integration
- Modelling & Simulation

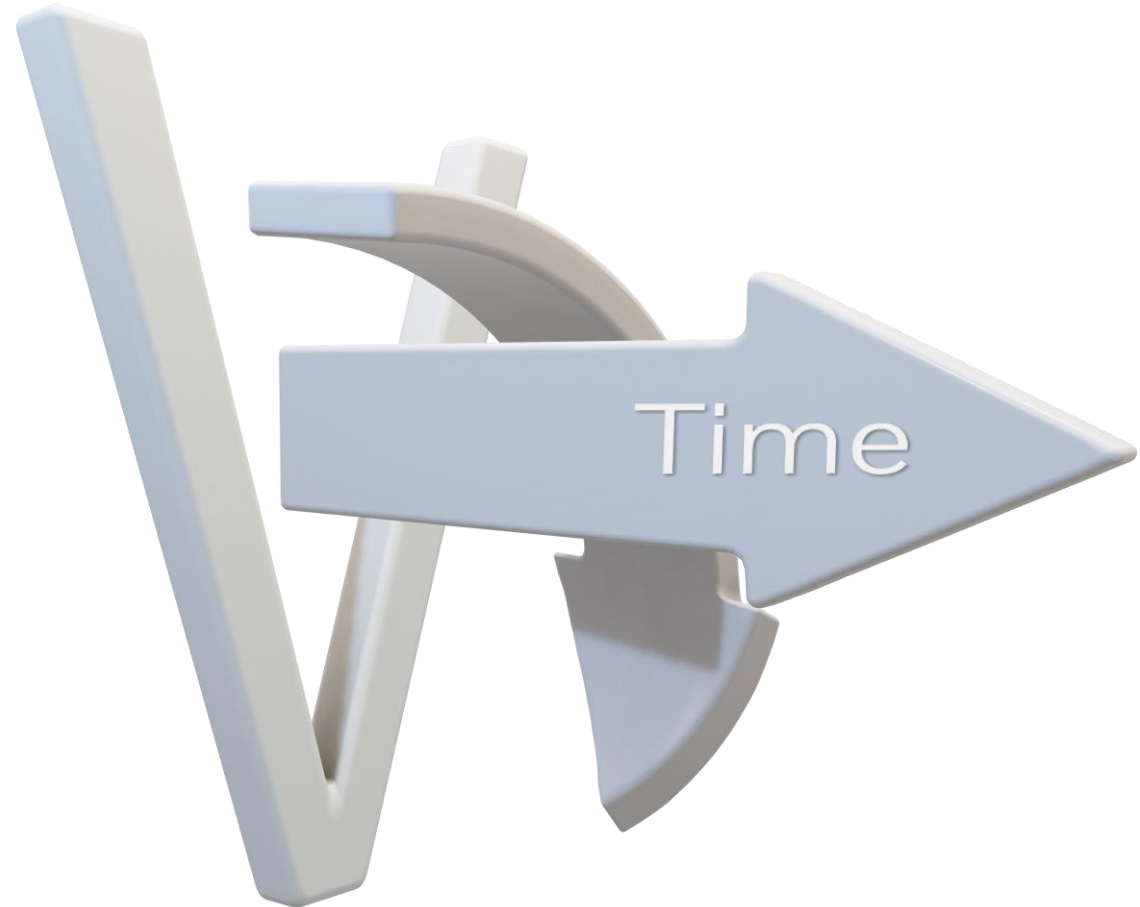

Automotive modelling and simulation historic view

Hardware in the Loop

- Vehicle Dynamics

- Multi-body simulation

- ABS standard

- Controllers

- Co-simulation

- Hardware in the Loop

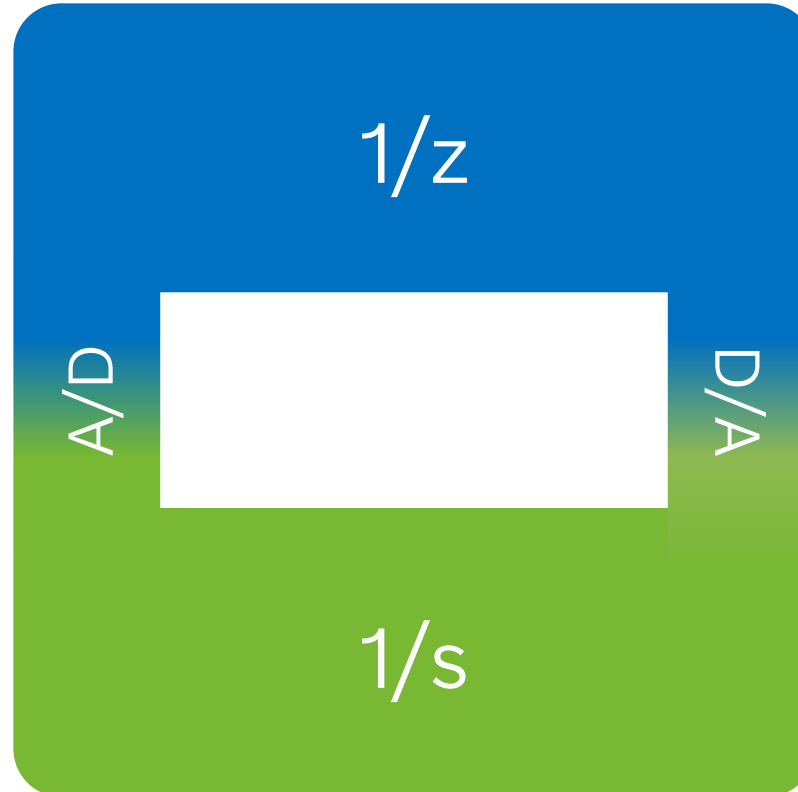

- A/D

- Anti-aliasing
- Sampling

- D/A

- Sampling
- Reconstruction

Automotive modelling and simulation historic view

Controls/actuators in the Loop

- Vehicle Dynamics

- Multi-body simulation

- ABS standard

- Controllers

- Co-simulation

- Software/Model in the Loop

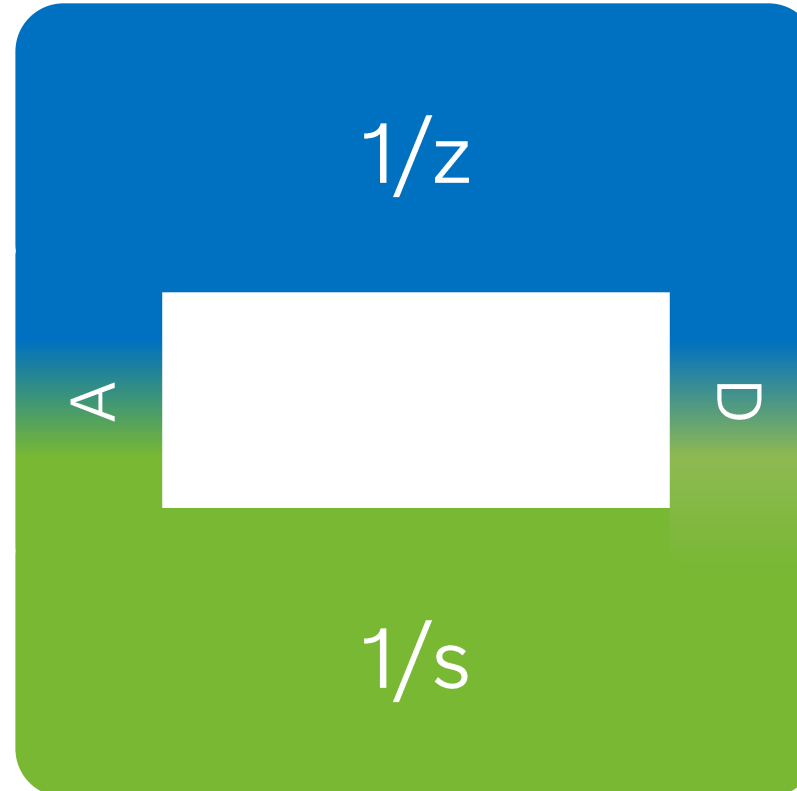

- D

- Sampling

- A

- Sampling

- Limited frequency content
- Mathematical ‘glue’

Automotive modelling and simulation historic view

Functional Mock-up Interface

Source: <https://fmi-standard.org/tools/>



[Tools](#) [Literature](#) [About](#) [FAQ](#)

- Functional Mock-Up Interface

- Open, non-proprietary, interface standard



FMI Version	Import	Export	Platform	License	Interface
1.0 2.0 3.0	CS ME	CS ME	Windows Linux Apple	\$ ©	File > Print

1.0 – 2010

2.0 – 2014

3.0 – 2022

- Good slow specification progression
- Maintains a small compatibility matrix
- Many vendors support standard

Co-Simulation - Stability Analysis

The Model

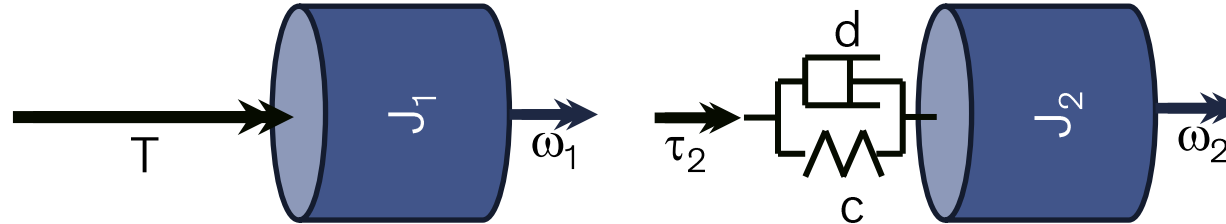

Transfer function with **ZOH Padé** approximants inserted

$$H_0 = \frac{J_2(ds + c)}{J_1 \left(\frac{h}{2}s + 1 \right)^2 (J_2s^2 + ds + c)}$$

Inertia ratio dominant factor of open-loop gain

$$H_0(0) = \frac{J_2}{J_1} = \frac{1}{\kappa}$$

Co-Simulation - Stability Analysis

Open-loop Nyquist

Stable

Unstable

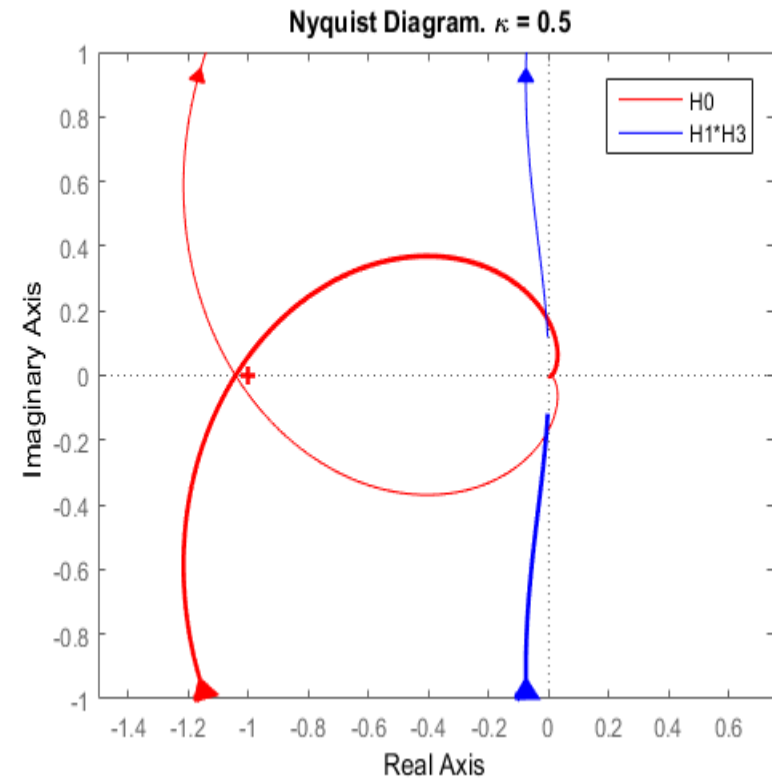
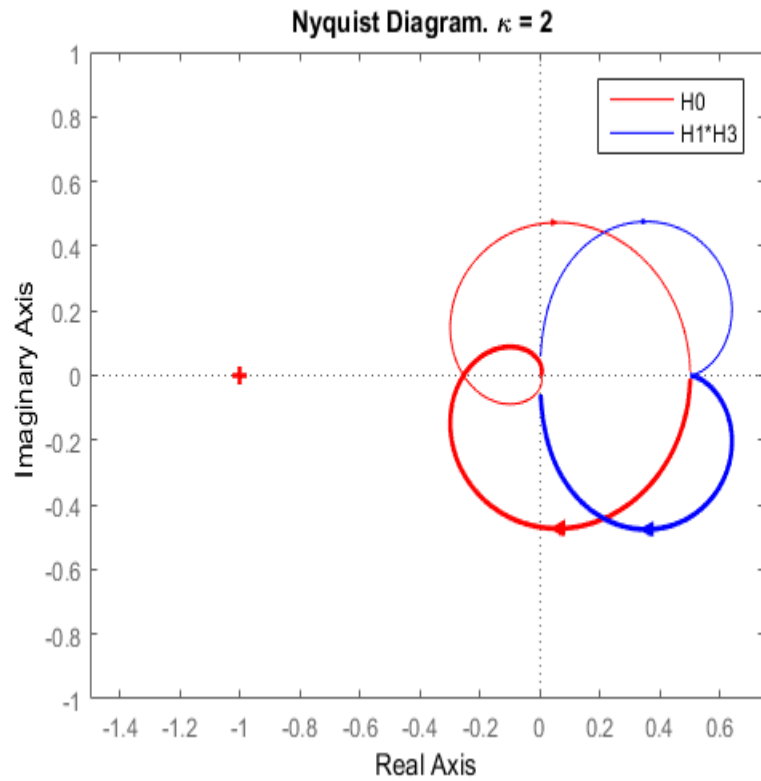

Inertia ratio to determine causality

Co-Simulation - Stability Analysis

Impulse Responses – Energy Preserving Connector Elements

Stable

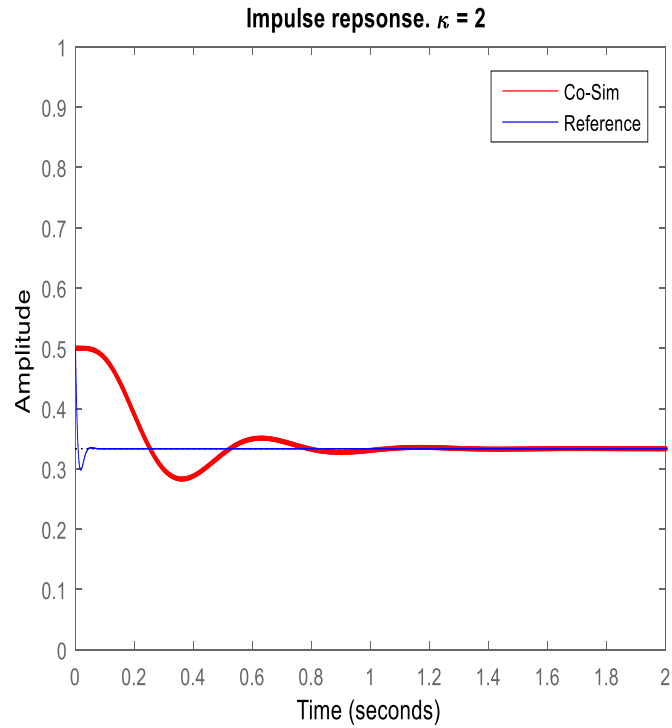

Unstable

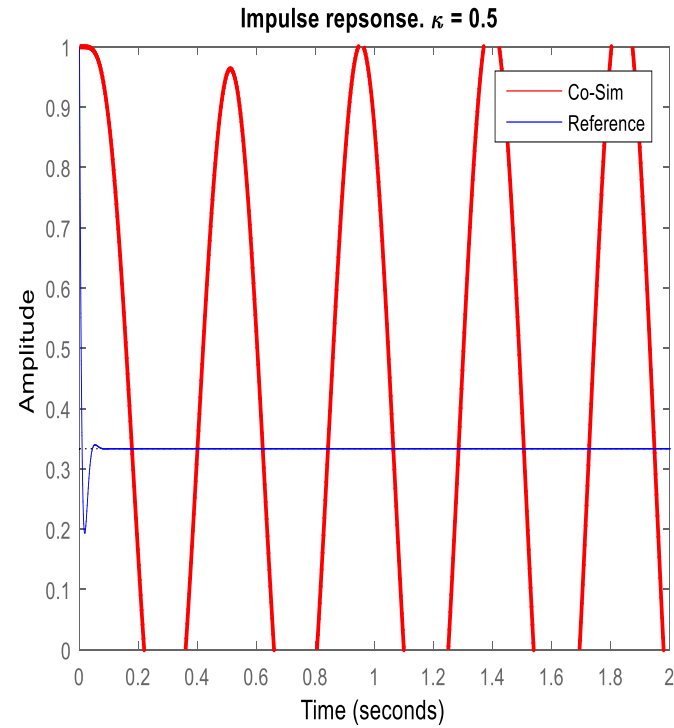

Co-Simulation - Architecture

Chained sub-systems - Energy Preserving Connector Elements

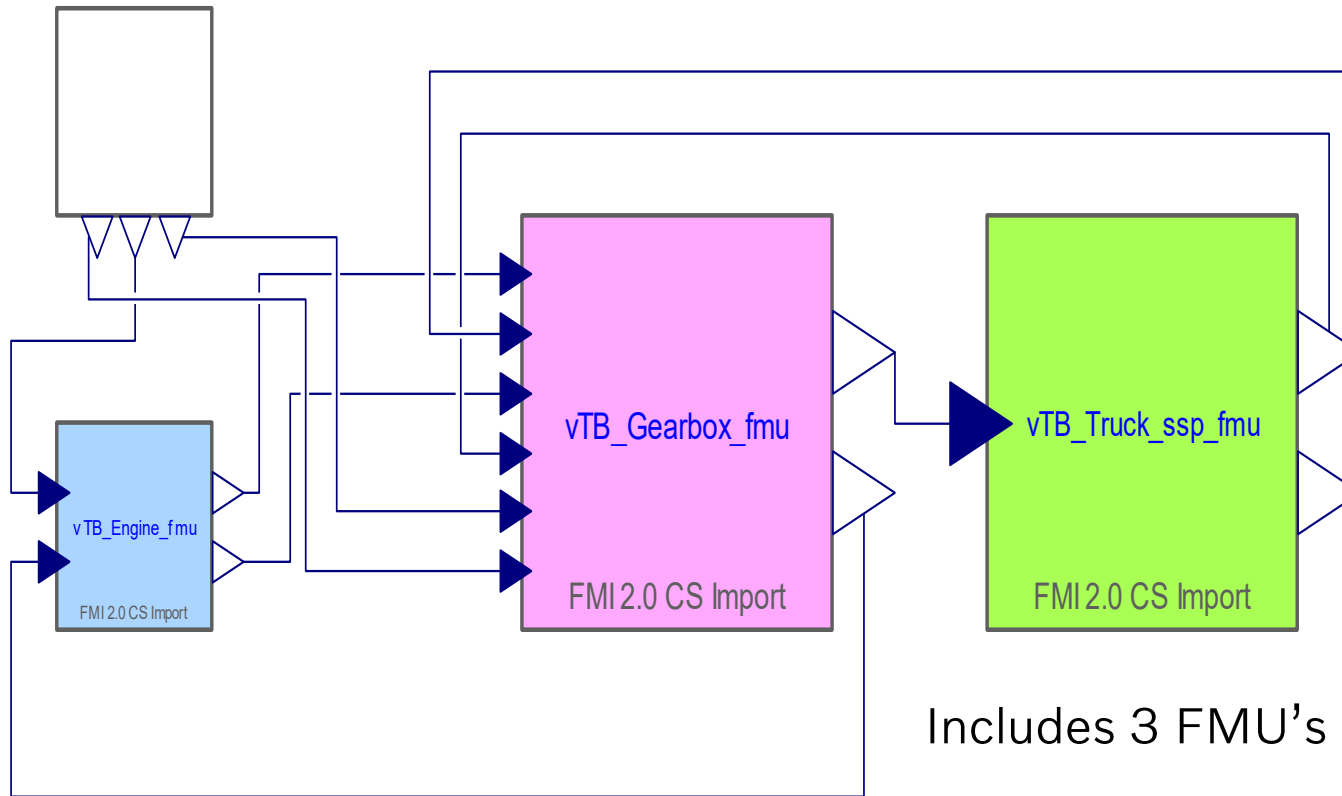

Source: "Virtual Truck & Bus" (2014- 007465)

Co-Simulation - Architecture

Aggregate FMUs - Energy Preserving Connector Elements

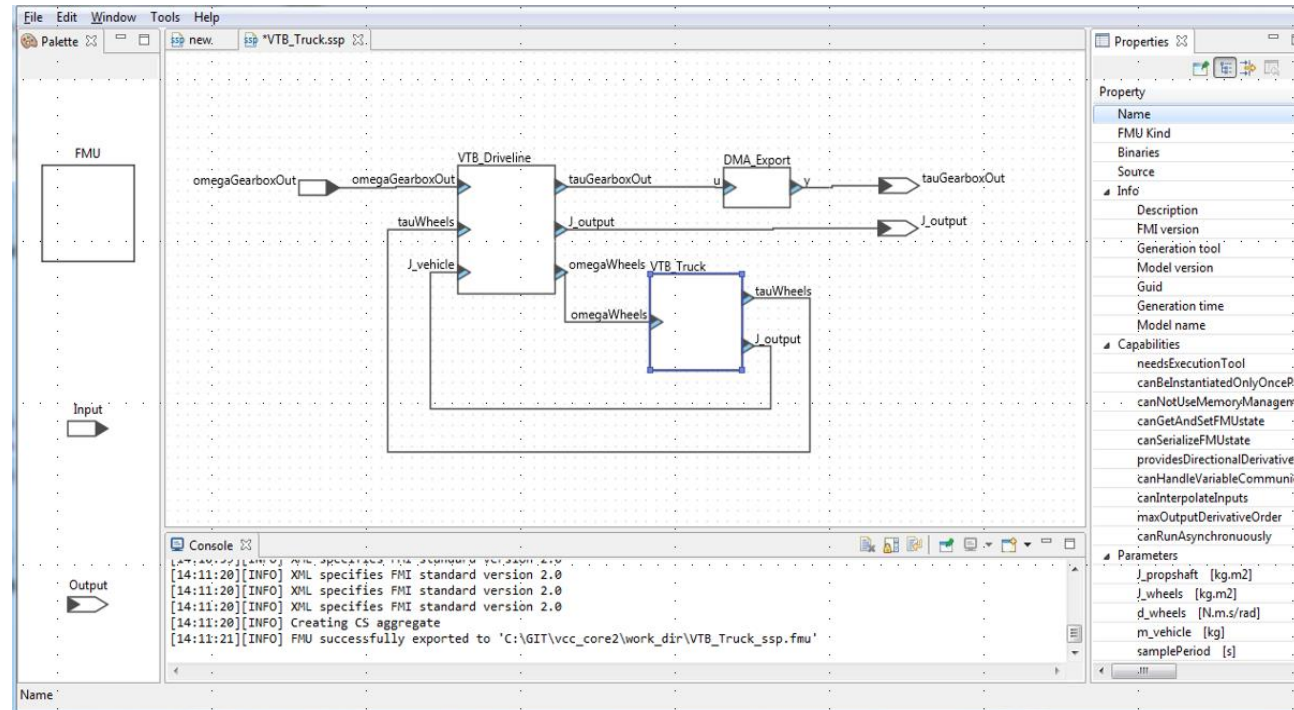

System Structure and Parameterization (SSP)

Source: "Virtual Truck & Bus" (2014- 007465)

Co-Simulation – Results

Acceleration Through Gears

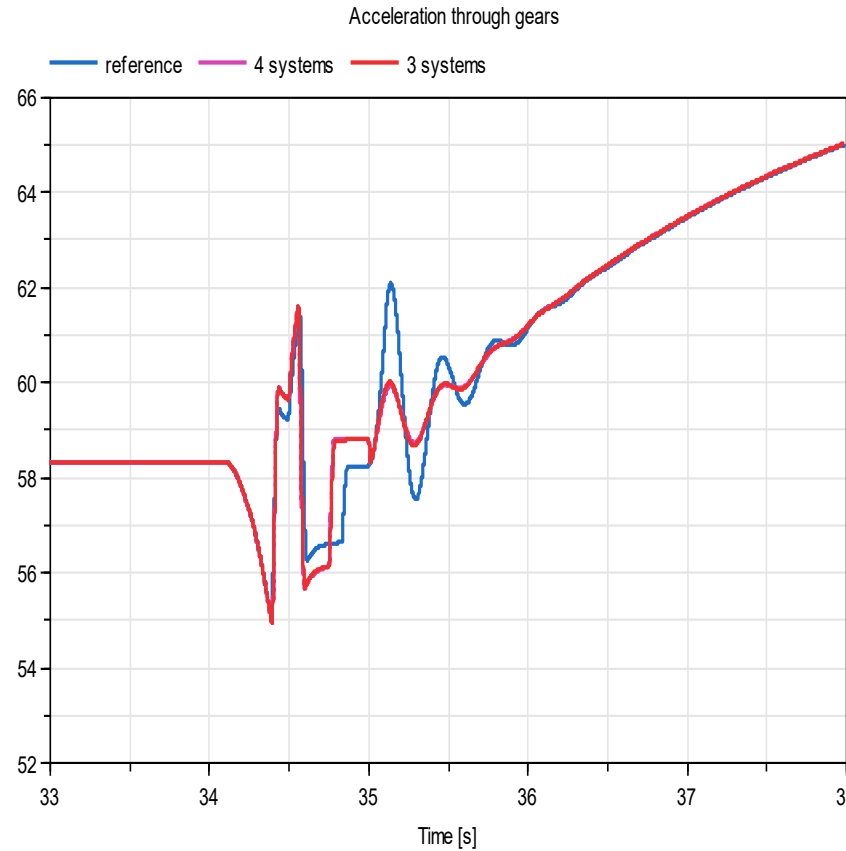
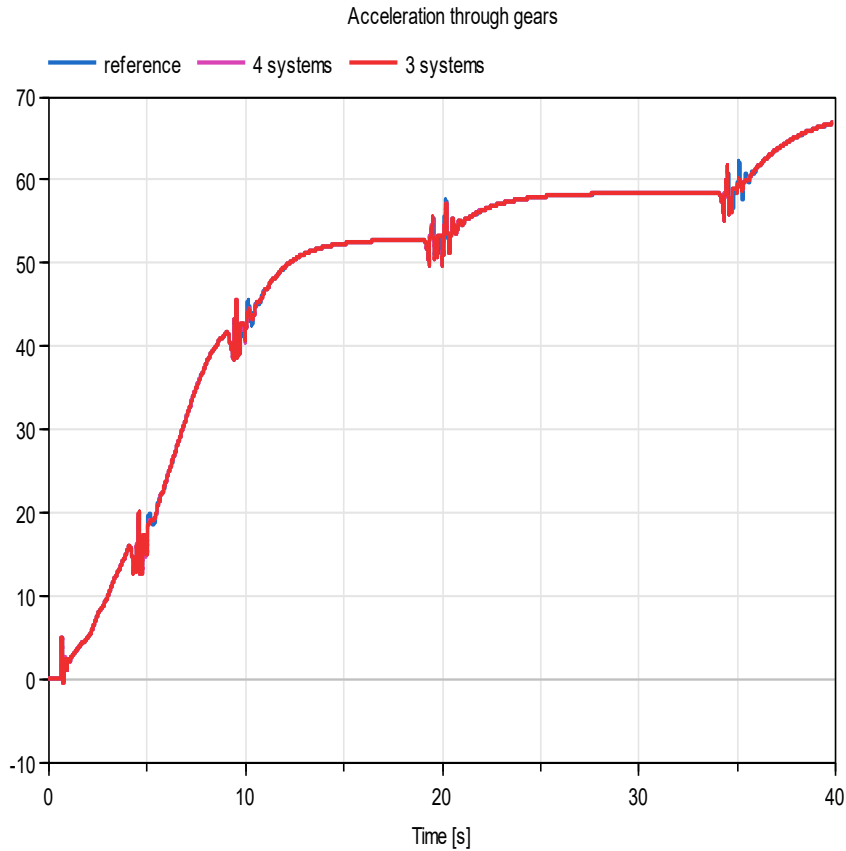

This is by no means trivial due to varying effective inertias

Transient signal distortion

Quick signal recovery

3- and 4-systems co-simulation basically identical results

4-systems has a performance penalty

Conclusions

Non-iterative co-simulation is control engineering

- Impedance ratio determines causality and stability
- One chained element determines flow
 - The remainder are effort loads
- System energy conservation required for asymptotic (steady-state) results
- Strict systems engineering required to design co-simulated plants

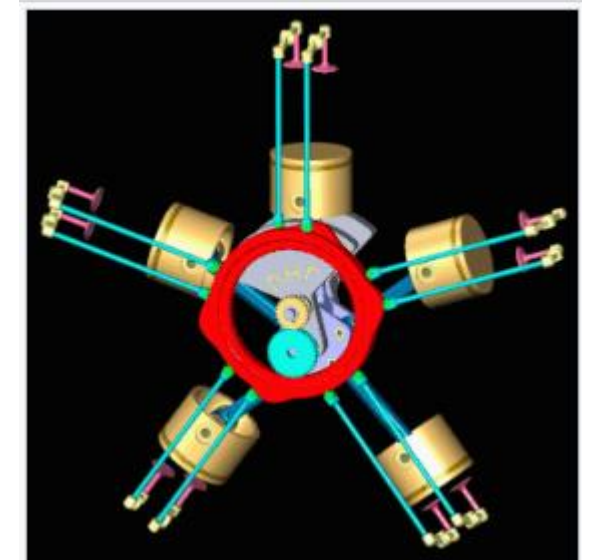

Source: Radial engine, Wikipedia

Software defined systems

Verification speed is key

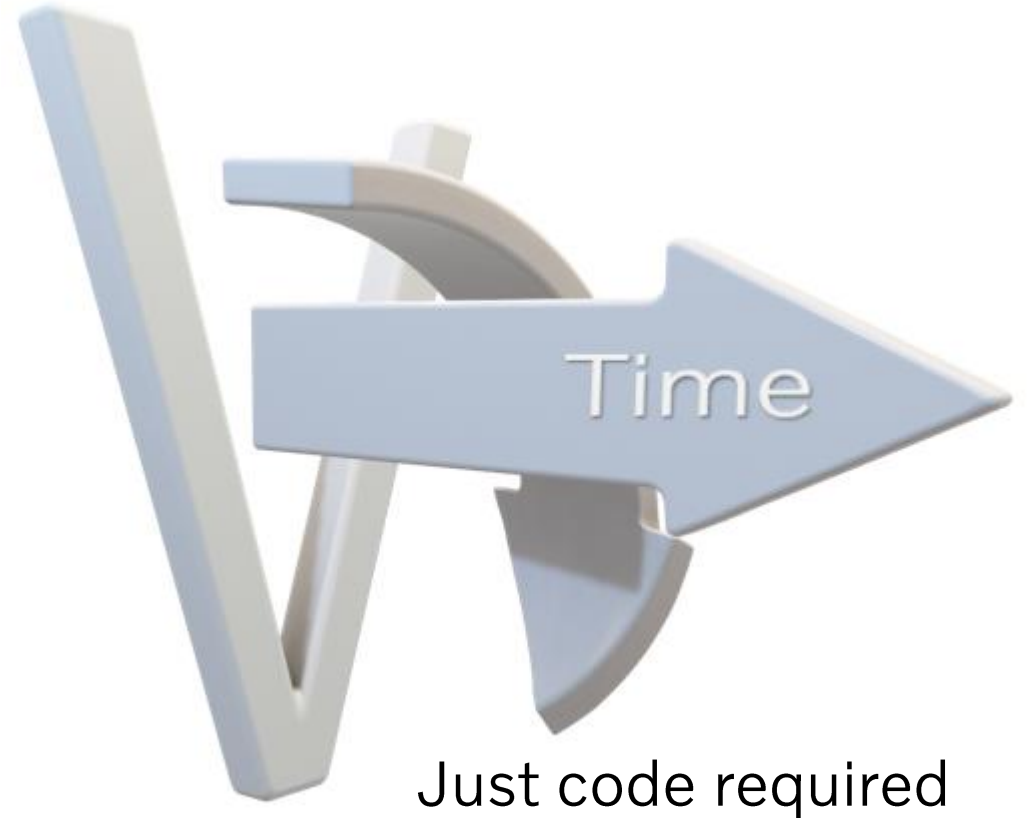
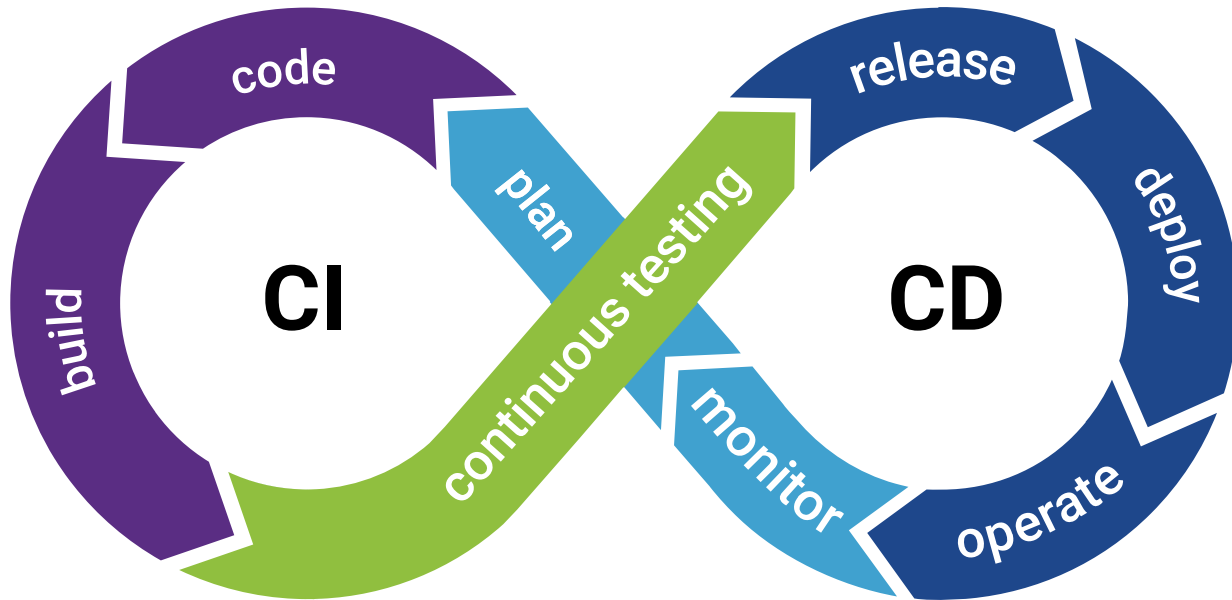

Just code required

Systems simulation in automation

FMU-factory

- Virtual development is a must for reaching vehicle/machine automation goals
- Physics modelling and co-simulation is not trivial. Conservation of energy!
- Model development requires regression and CI/CD for assured quality and robustness
- FMU-factory to govern model proliferation for virtual development in multiple integration platforms



Mileage is everything

Acausal paradigm

- Plant model (code) re-use
- Incremental changes with regression
- Declarative (acausal) models are reusable assets in multiple load/test cases
- Imperative (causal) models may require substantial rework even with minor updates

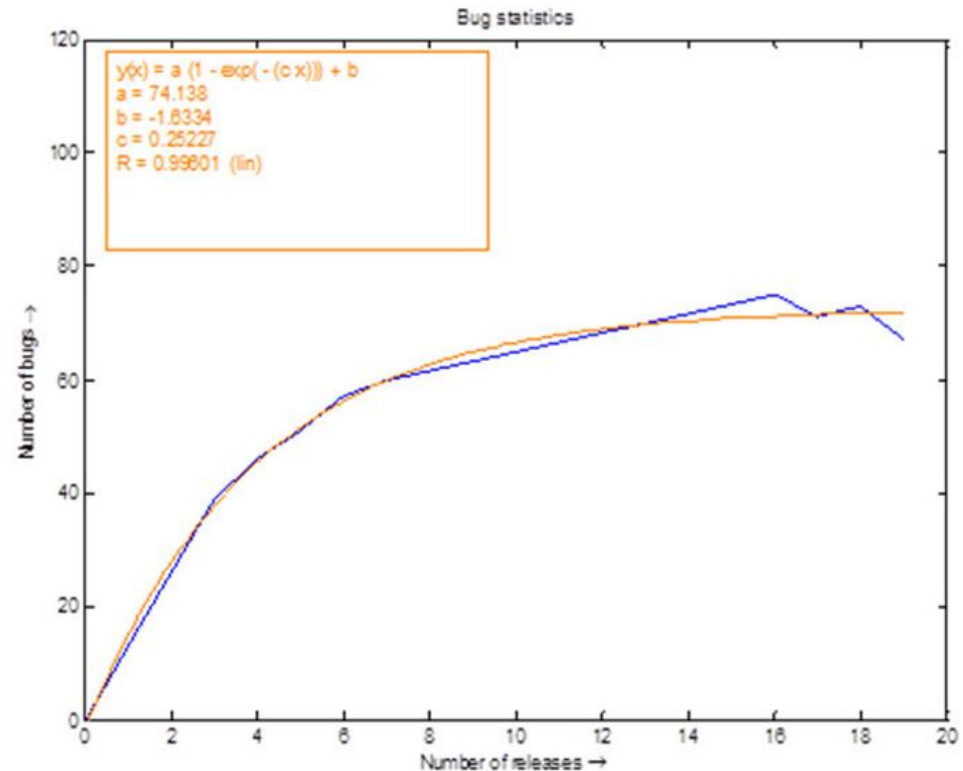

Source: <https://www.linkedin.com/pulse/heterogeneous-robust-design-edo-drenth>

Plant model requirements

Robust models

- Whatever happens, the simulation needs to carry on
 - A roll-over or a “physical” crash is a possible simulation outcome
 - It may not lead to a premature simulation execution failure
- Model requirements
 - First principles physics
 - Sound extrapolation
 - No use of tables
- Execution requirements
 - Faster than real-time

PHYSICAL MODELLING PRINCIPLES

- Effort – flow
 - Bond graph theory
- Never ever use a derivative operation
 - All (!) problems can be rewritten to have integrators only
 - Modelica’s **der()** is an operator, not an operation
- An algebraic loop is a ‘bug’
 - ... and treat it as such; no memory block!
- Do not extrapolate tables nor polynomials
 - Aim for natural functions
- Follow Style & Coding guidelines

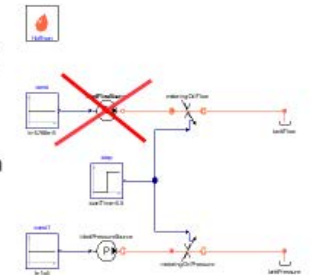

Vehicle/machine model definition

Dynamic agent

- Mathematical description of the real-world vehicle behavior.

Constructed of:

- Plant model: Differential-algebraic equations
- Base vehicle control logic
- Base vehicle control functionality
- Signal/message interfaces
- Simulation interfaces

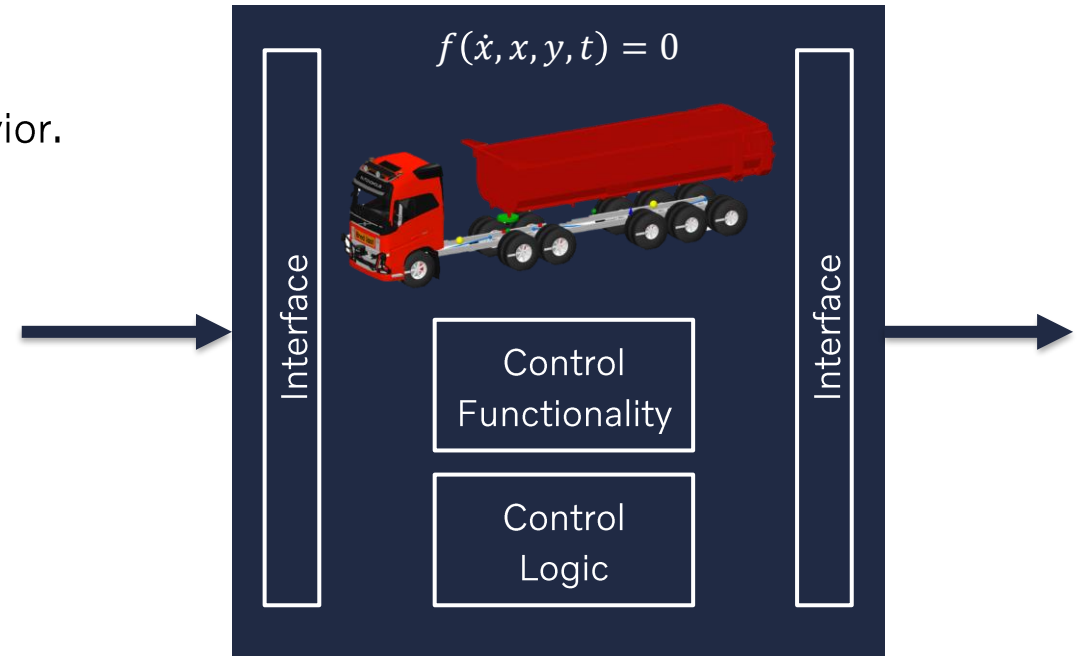

- Single executable: non-iterative co-simulation

Library regression

Controlling model evolution

- Reference results
- No commits on master
- Automatic pipelines per branch
- Merge requires approved
 - Code review
 - Regression

- Just code → Version control → Incremental quality control

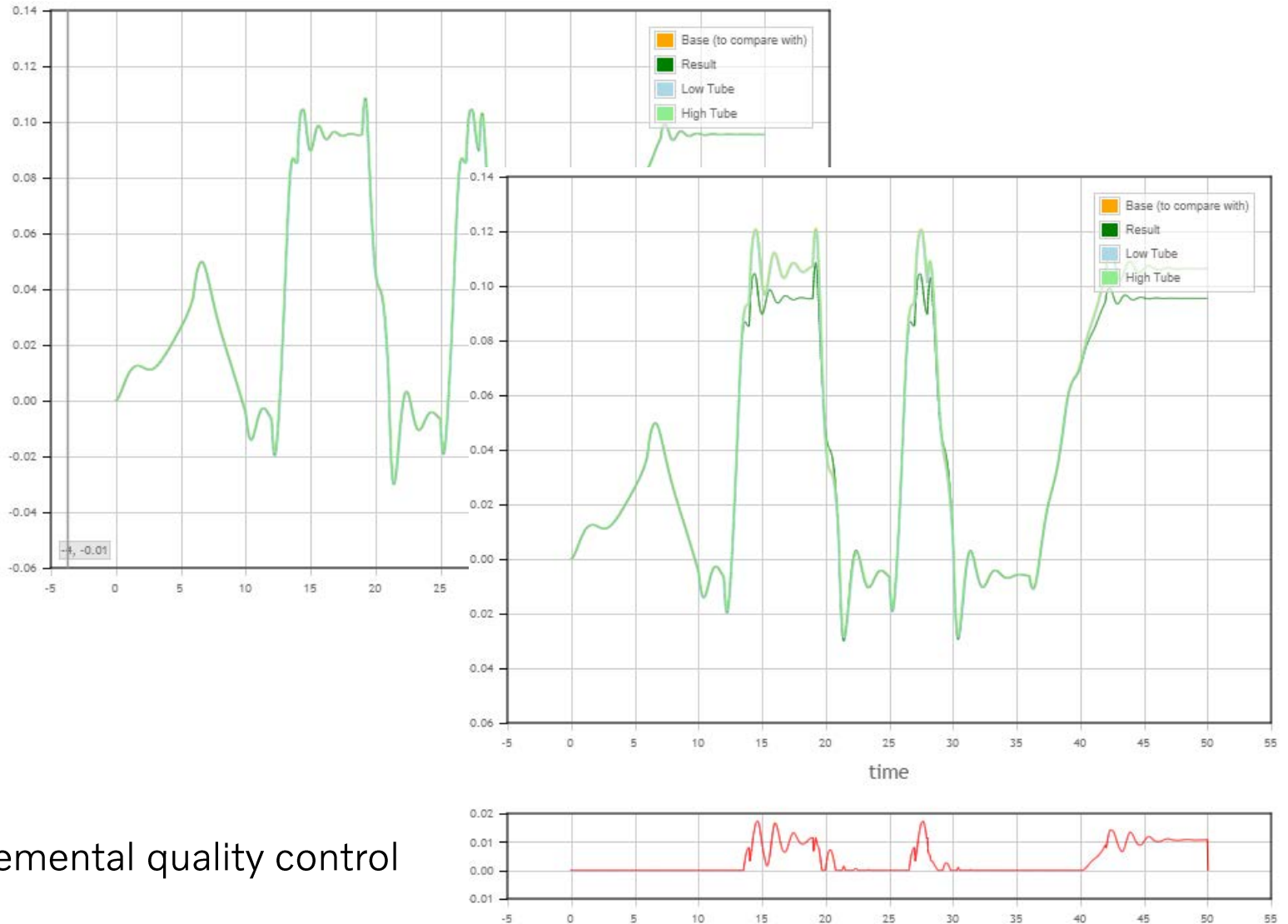

It's just code



V.A.S FMU-Factory

Software Aided Engineering

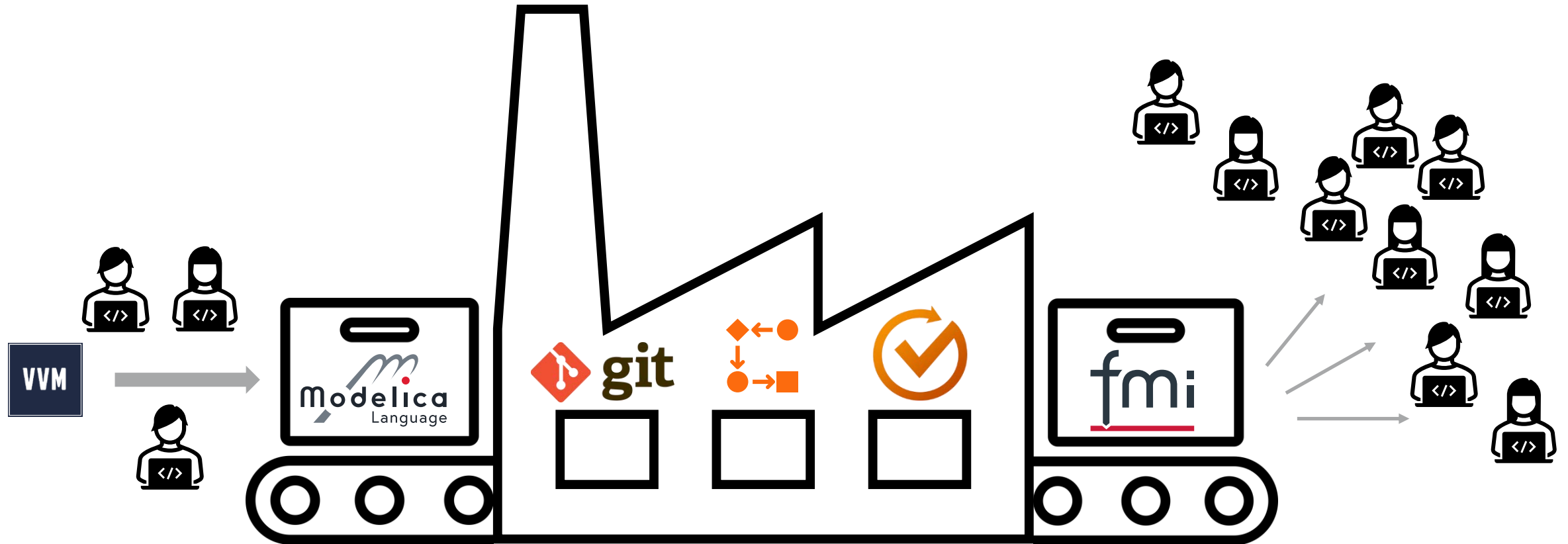

Where do we go from here?

Augmented model automation

- Purpose driven fidelity models
- First principal physics is combined ancestors' intelligence
- ML/AI to find fidelity discrepancies

The model at hand
represents
a possible outcome of a real system

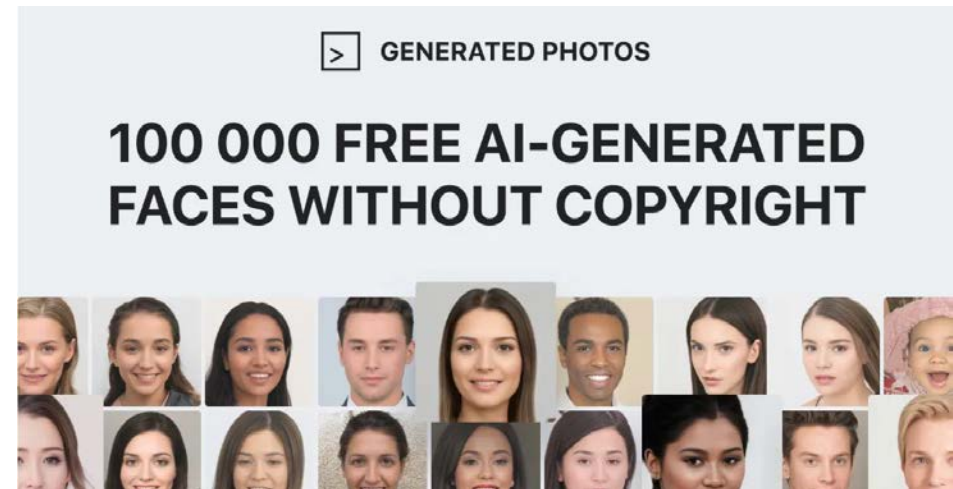

Systems simulation

The essence

“If you want to find the secrets of the universe, think in terms of energy, frequency and vibration.”

— Nikola Tesla

“If you want to find the secrets of *systems simulation*, think in terms of energy, frequency and vibration.”

V O L V O

Presentation 3:
***Target Cascading from Full Vehicle Dynamics
Targets to System & Subsystem Vehicle
Requirements***

Axel Villandseie, Volvo Cars

VOLVO

Target Cascading from Full Vehicle Dynamics Targets to System & Subsystem Vehicle Requirements



Target Cascading from Full Vehicle Dynamics Targets to System & Subsystem Vehicle Requirements,
Axel Villandseie, Volvo Cars

2025.05.07

About the project

Systematic design process for the concept phase that asserts fulfillment of overall vehicle dynamics targets.

- Eliminates the need for complex (MBS) models for concept design
- Removes the need of component parametrization in early phases
- Cascade full vehicle targets into system & subsystem requirements

Developed together with FKFS in Stuttgart, based on the dissertation *Entwicklung einer fahrwerksauslegungsmethode für pkw zur anwendung in der konzeptphase* (Hendrik Abel, 2019) (*Development of a chassis design method for cars in the concept phase*)

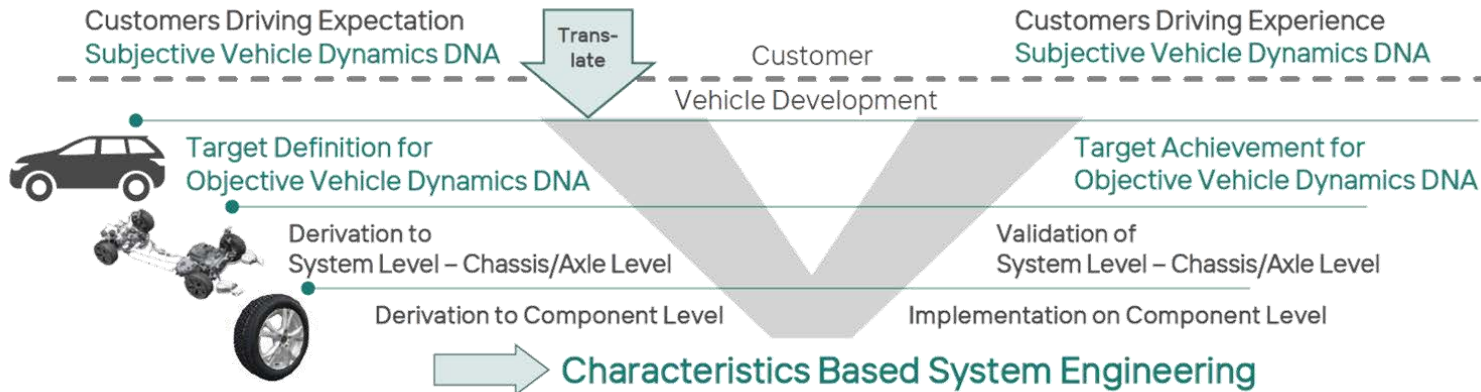

About the project

1. Objective full vehicle criteria

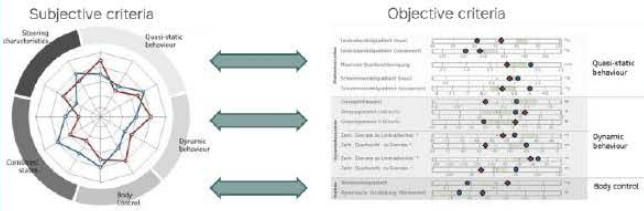

2. Efficient vehicle models with reduced complexity

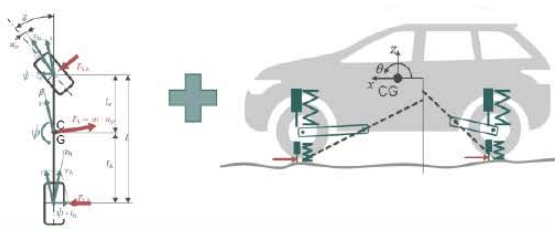

3. Target cascading + solution space

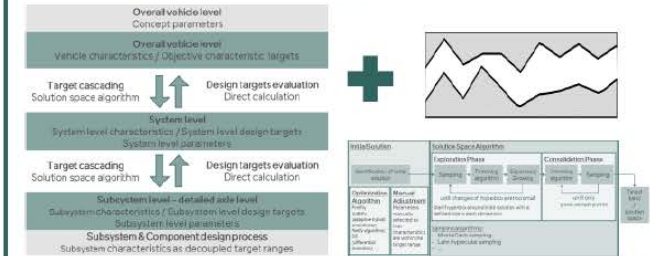

Tool developed in Python



Enhanced Single track model

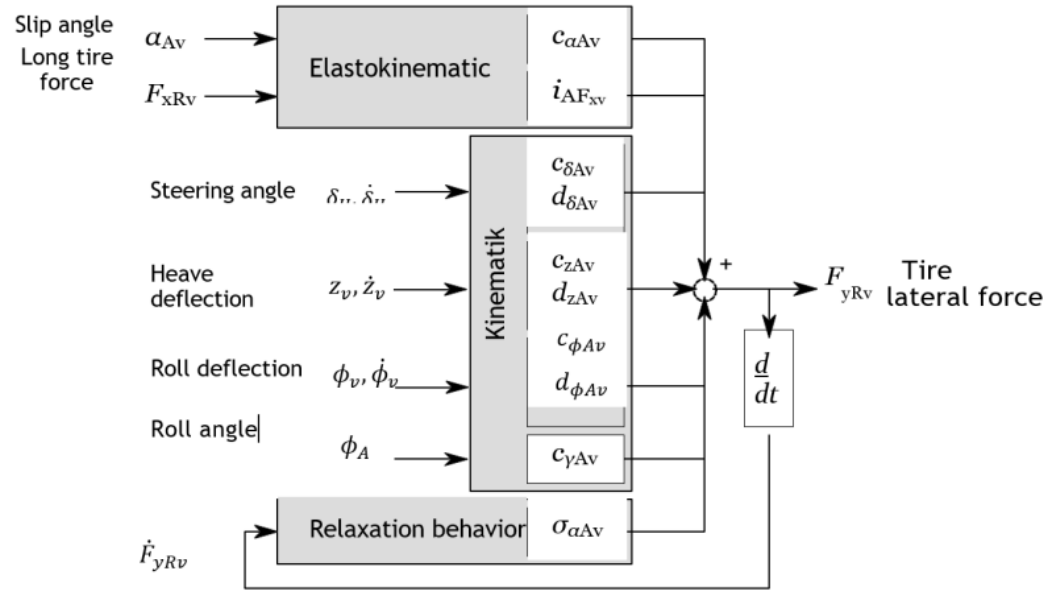

System to subsystem (effective axle characteristics)

$$c_{\alpha A} = c_{\alpha R} \left(1 - \frac{c_{\alpha R}}{C_{\delta F_{y,Di}}} - \frac{c_{\alpha R}}{C_{\delta F_{y,In}}} - \frac{c_{\alpha R} n_R}{C_{\delta M_{z,Di}}} - \frac{c_{\alpha R} n_R}{C_{\delta M_{z,In}}} - \frac{c_{\gamma R}}{C_{\gamma F_{y,Di}}} - \frac{c_{\gamma R}}{C_{\gamma F_{y,In}}} - \frac{c_{\gamma R} n_R}{C_{\gamma M_{z,Di}}} - \frac{c_{\gamma R} n_R}{C_{\gamma M_{z,In}}} + \frac{c_{\alpha R} i_{F_y}}{C_L i_{\delta^*}} + \frac{c_{\gamma R} i_{F_y}}{C_L i_{\gamma^*}} \right)^{-1}$$

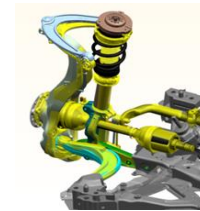
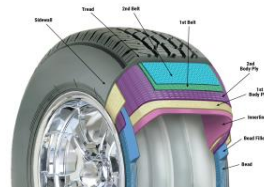
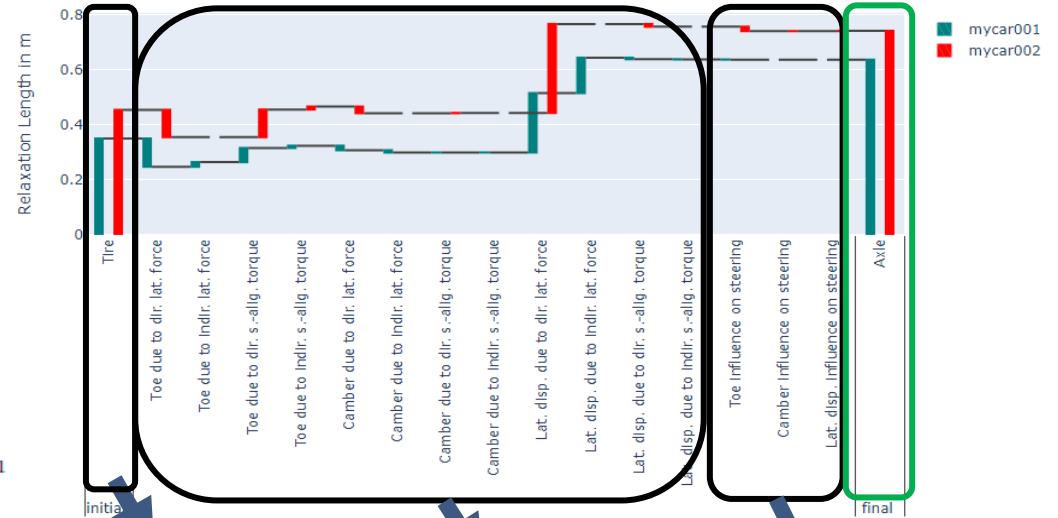

Solution space algorithm

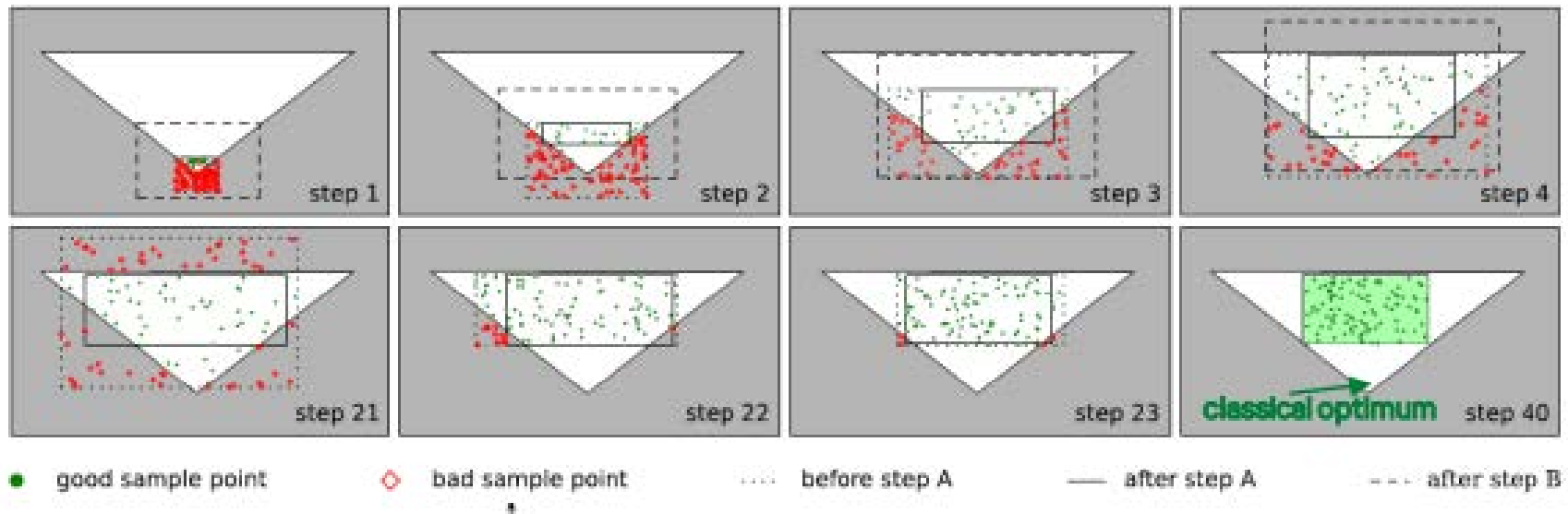

Visualization



super system level



system level



subsystem level



Concept level: Overall vehicle parameters, such as mass, wheelbase, inertias, cog-height etc.

System level: Overall system characteristics, such as vertical stiffness, roll stiffness, damping, roll center height, steering ratio

Subsystem level: Linearized suspension characteristics, such as tire cornering stiffness, tire relaxation length, bump steer, compliance steer, EPAS assist, etc.

Effective axle characteristics: Input to the vehicle model. Calculated based on subsystem parameters. For example, axle cornering stiffness, axle relaxation length, axle camber stiffness, axle roll kinematic stiffness + damping

Objective requirements: Can be calculated as a result from the vehicle model. If the solution space algorithm is to be used, the objective requirements act as the cost function.

A silver Volvo SUV is shown from a rear perspective, driving on a winding asphalt road that curves along a body of water. The scene is set during sunset or sunrise, with a warm, golden glow in the sky. The car's license plate reads "MLB 060". The background features a rocky shoreline with trees and a clear sky. The overall mood is serene and scenic.

V O L V O

Thank you for your attention!
Questions?

Presentation 4:

***Rolling resistance on roads with various
weather and surface conditions***

Mikael Askerdal, Volvo LV and Chalmers

Rolling resistance on roads with various weather and surface conditions

Mikael Askerdal, AB Volvo

Content

- Rolling resistance model overview
 - static and dynamic
- Tire temperature measurements in different weathers and road conditions
- Implications of a linear heat dissipation model
- Conclusions

Overview and definitions of rolling resistance

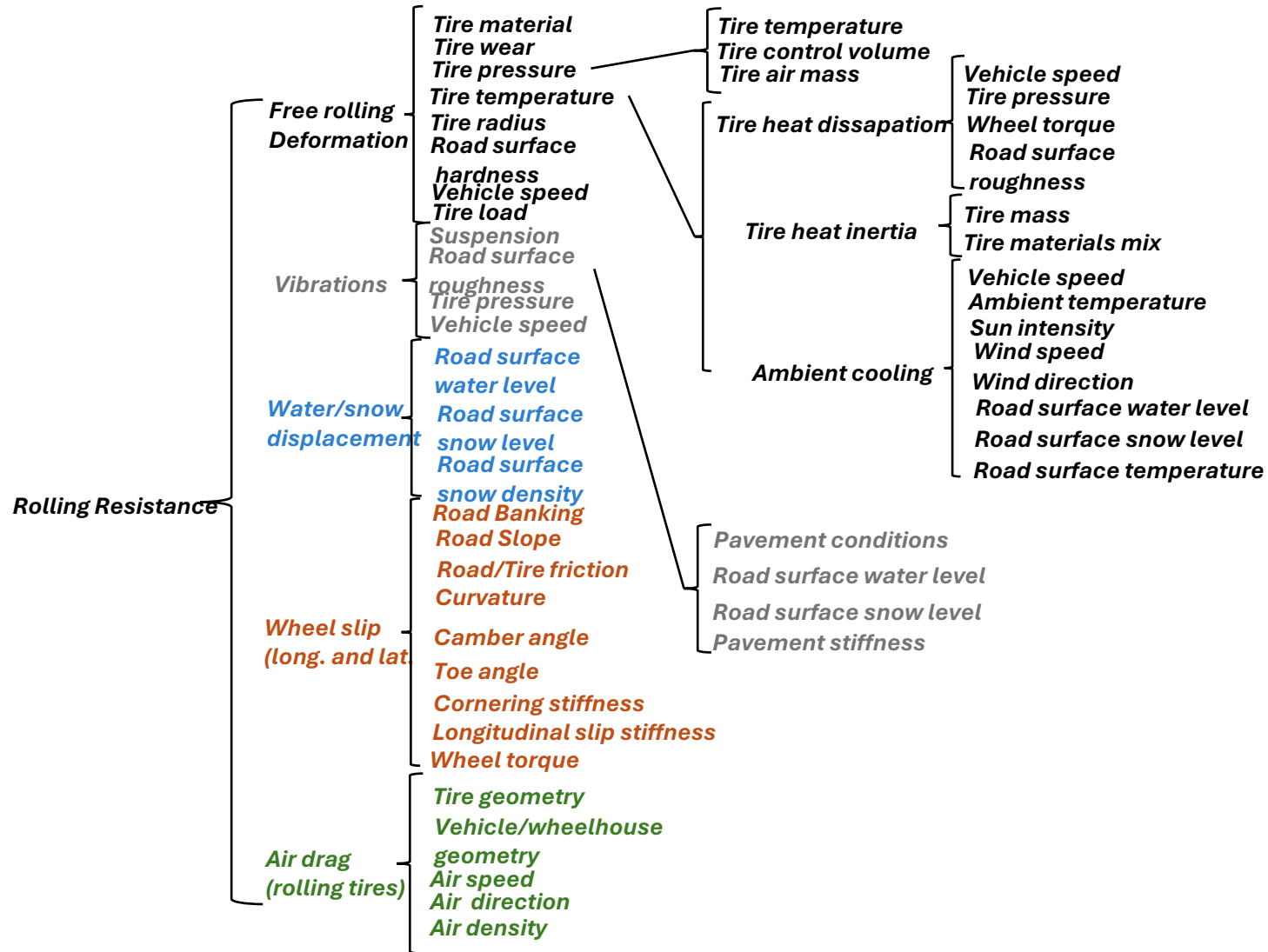

Overview and definitions of rolling resistance

How is rolling resistance defined?

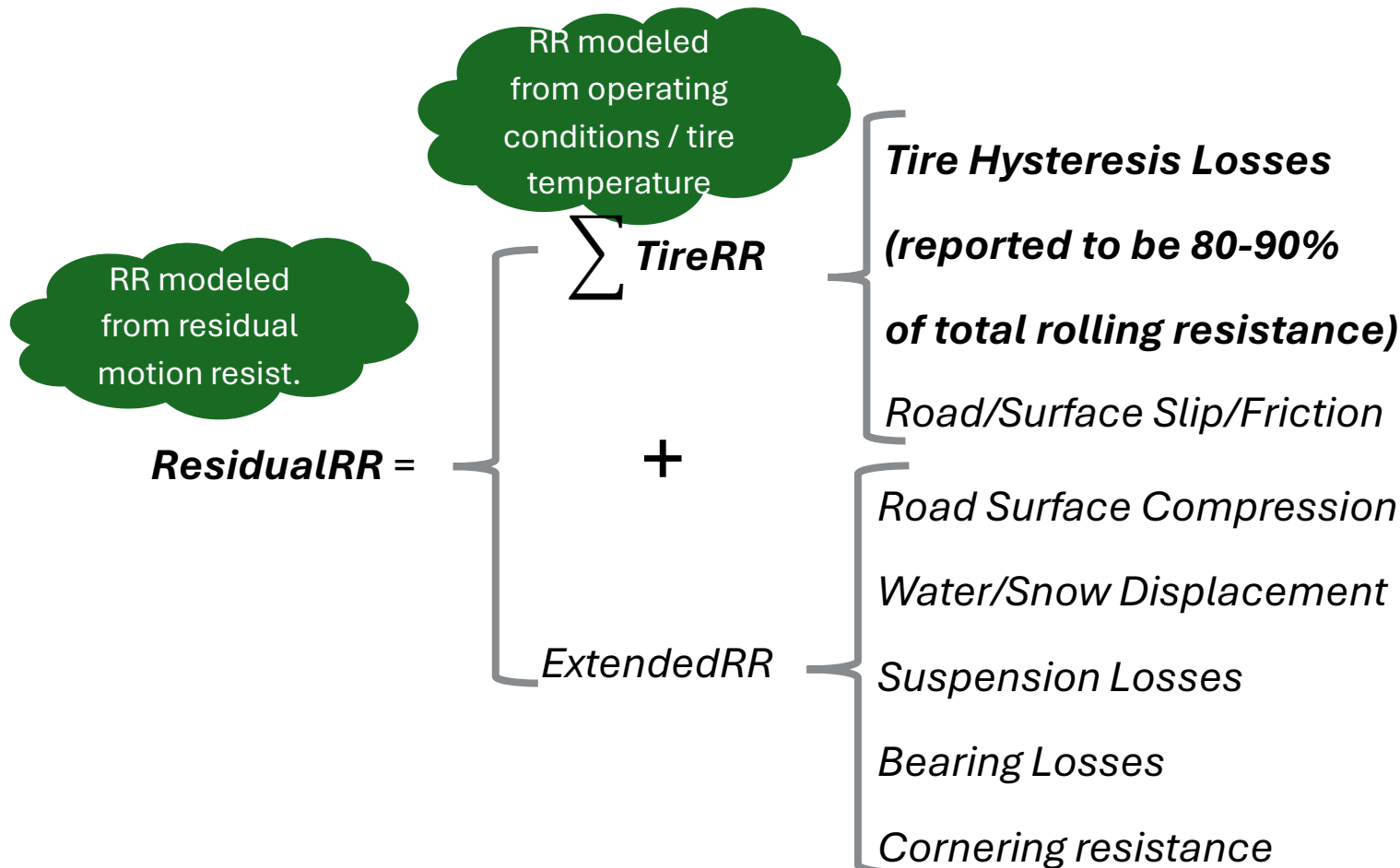

(Hyttinen et. al (Scania))

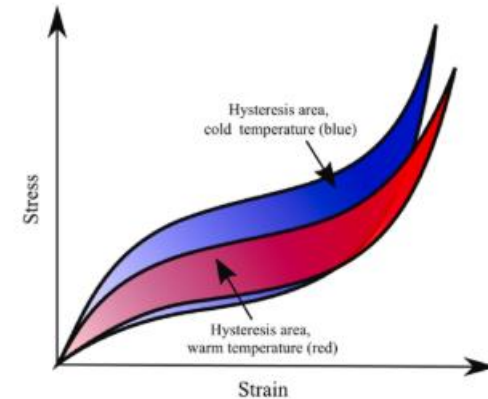

Fig. 2. Filled rubber hysteresis at different temperatures. The increase in temperature causes a decrease in hysteresis area and stiffness.

“the mechanical energy converted into heat by a tire moving for a unit distance on the roadway”

Tire rolling resistance model development

RR as a function of operating conditions / tire temperature

(Hyttinen et. al (Scania))

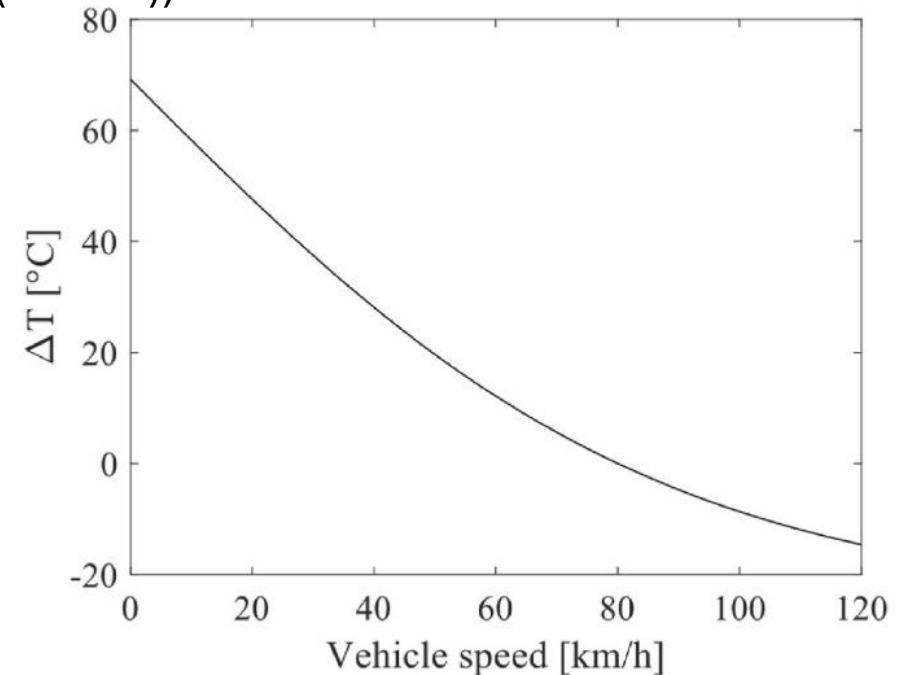
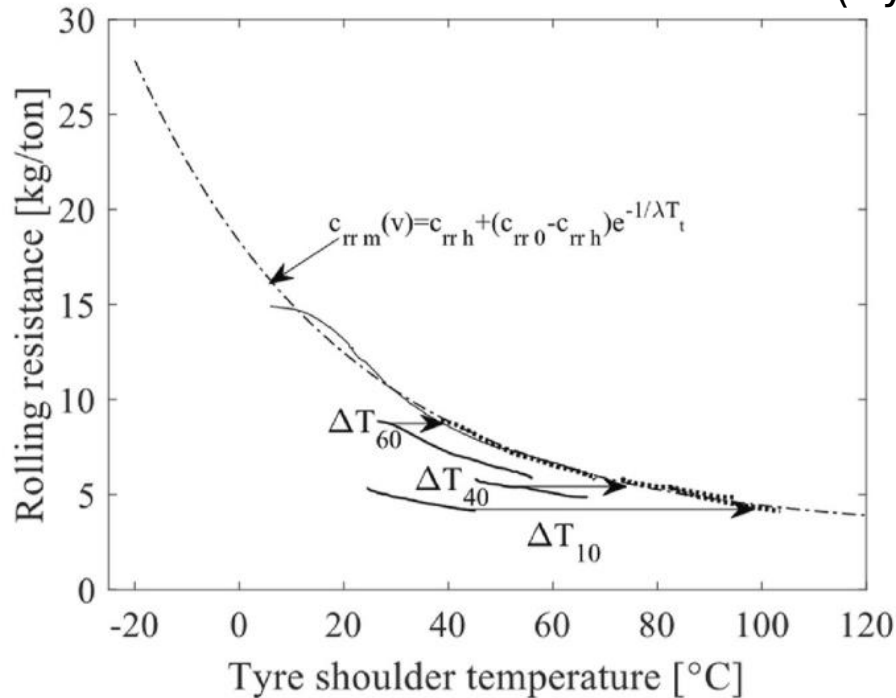

Fig. 27. The shift temperature (ΔT) at different speed levels.

$$c_{rr}(T_t, P_t, v) = \frac{\|F\| (c_0 + c_1 e^{-c_2 T_t} + c_3 e^{-c_2 T_t} \log(v + 1)) P_t^{-0.5}}{F_Z}$$

Ongoing work

Create a dynamic rolling resistance and tire temperature model taking road weather into account

Tests at "långa banan", VTI, Linköping, to find a model on how rolling resistance depend on operating conditions, i.e.

- Tire temperature
- Tire pressure
- Vehicle speed (5-36 km/h)



RR vs tire temperature

- Black - 6.8 °C
- Red – 16.7 °C
- Green – 20.3 °C
- Blue – 20.6 °C

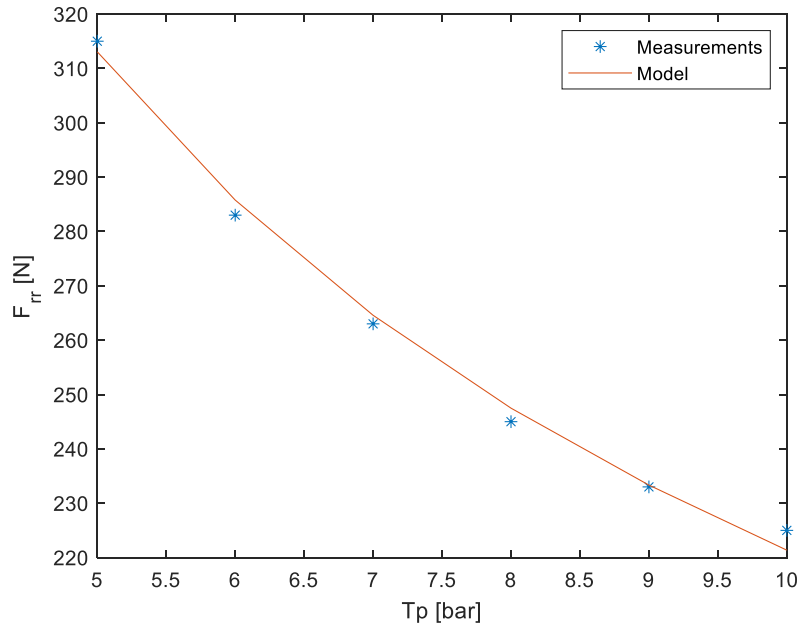

$$C_{rr} \approx C * P_t^{-0.5}$$

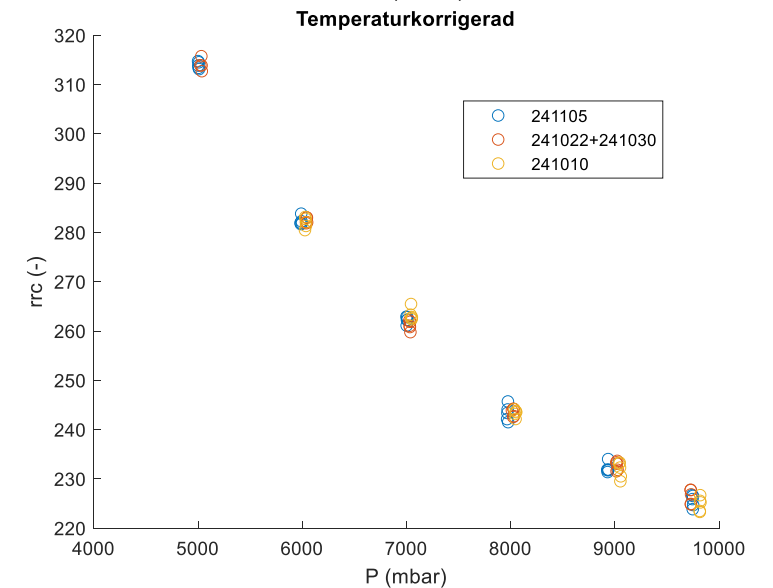
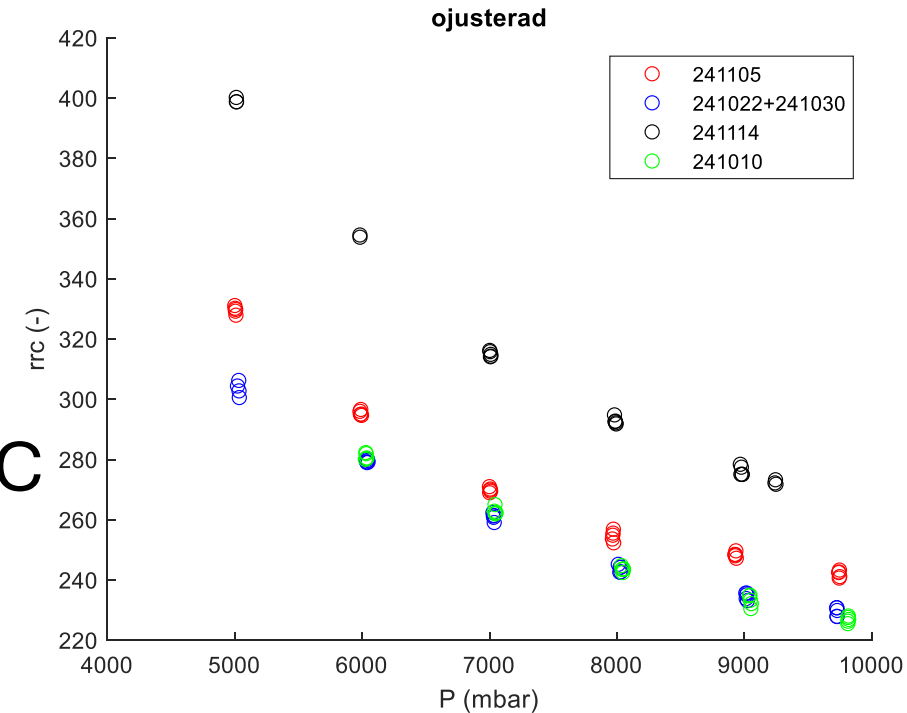

Vehicle speed

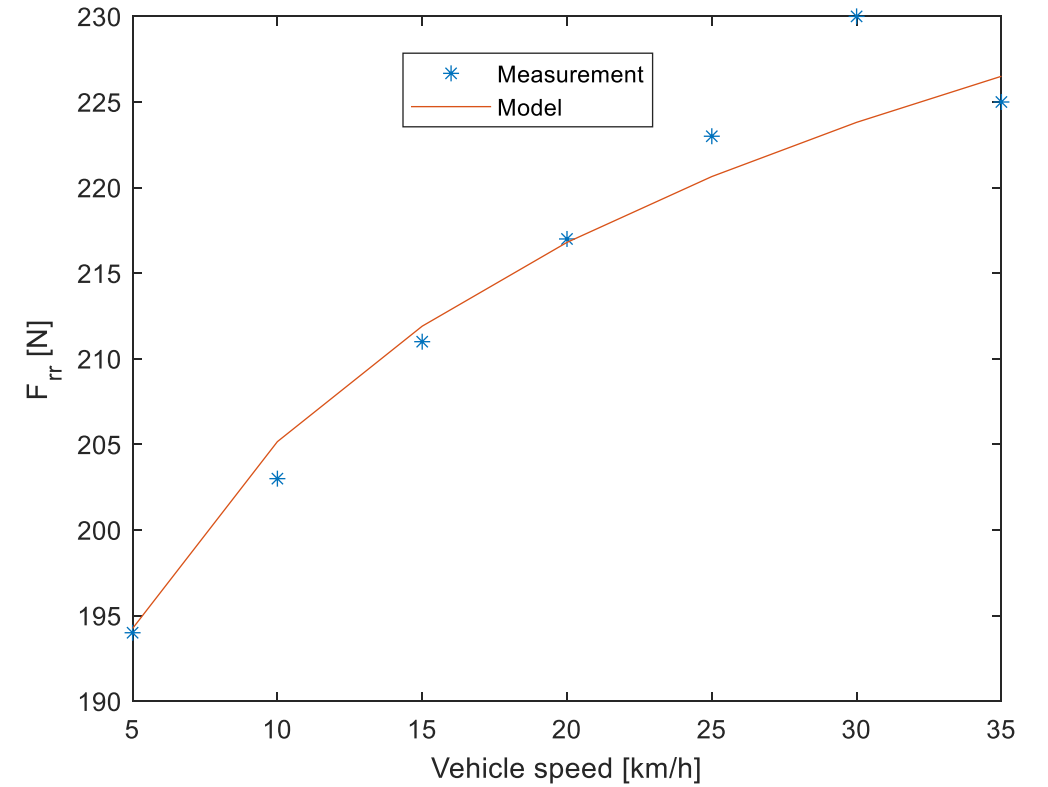
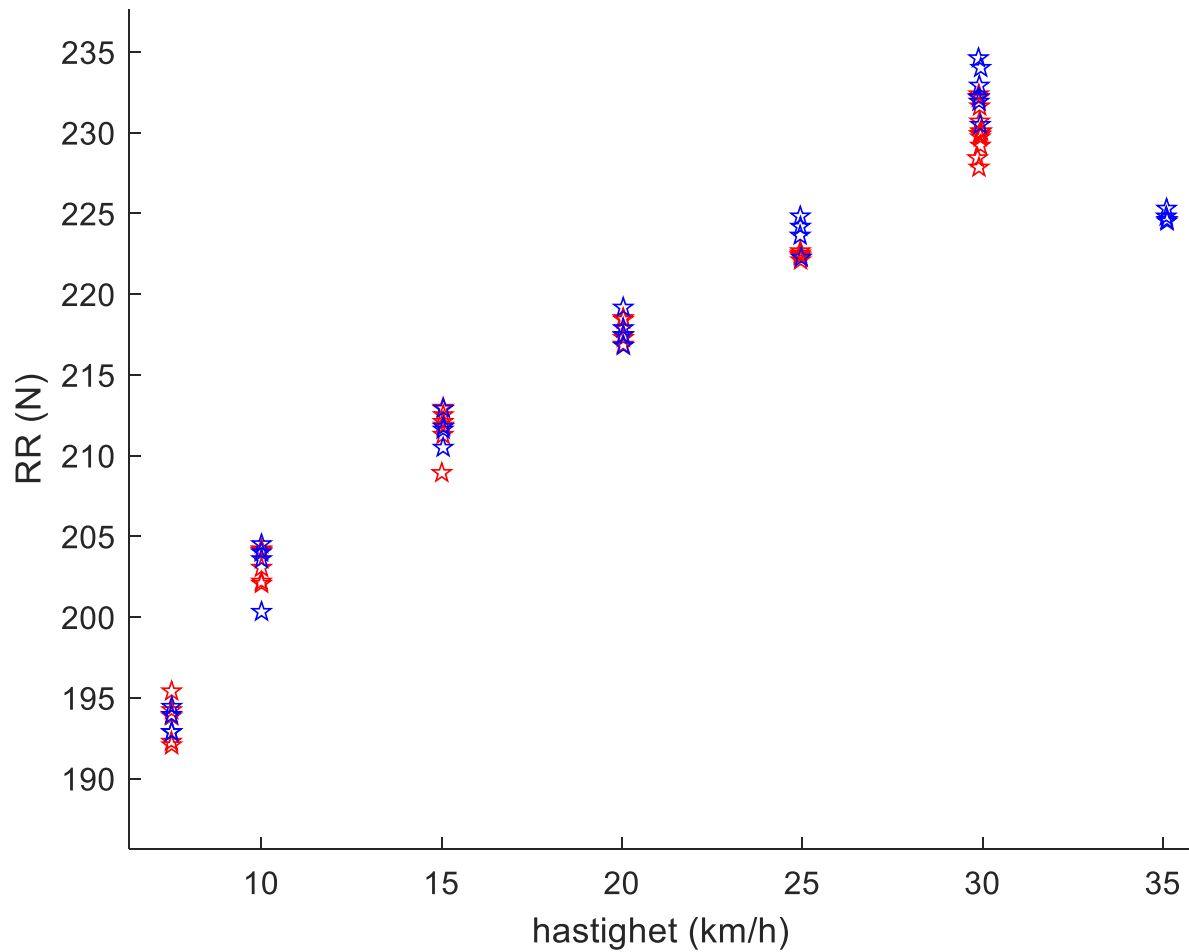

$$c_{rr} \approx C * \log(v + 1)$$

Next steps

Create a dynamic rolling resistance model and a rolling resistance observer that take various road weather into account

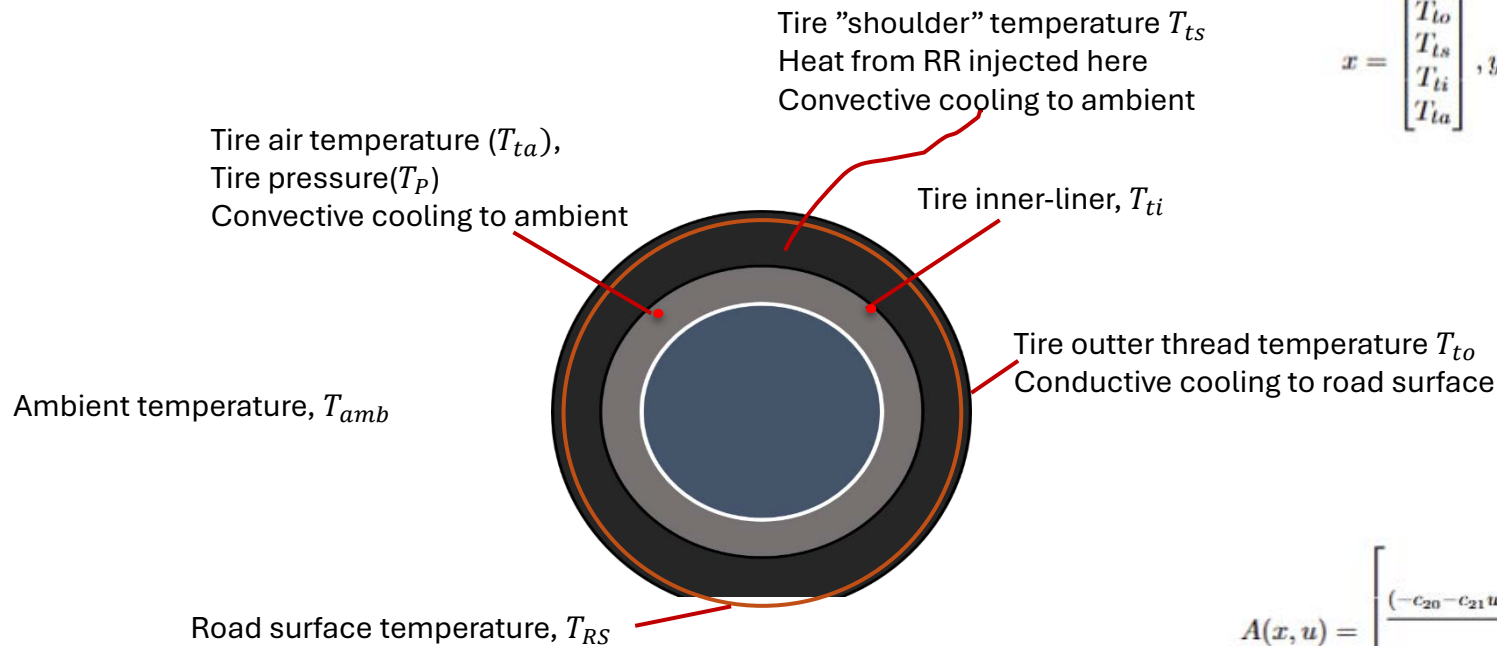

Conductive heat transfer between different parts of tire

$$x = \begin{bmatrix} T_{to} \\ T_{ts} \\ T_{ti} \\ T_{ta} \end{bmatrix}, y = Cx + D; C = \begin{bmatrix} 1 & 0 & 0 & 0 \\ 0 & 0 & 1 & 0 \\ 0 & 0 & 0 & n_{air} \end{bmatrix}, D = \begin{bmatrix} 0 \\ 0 \\ n_{air} * 273.15 \end{bmatrix} \quad (1)$$

$$u = \begin{bmatrix} v_v \\ F_{tot} \\ T_{rs} \\ T_a \end{bmatrix} \quad (2)$$

$$\dot{x} = A(x, u); \quad (3)$$

$$A(x, u) = \begin{bmatrix} \frac{(-c_{10} - c_{11}u_1 + c_{13}u_1^2)(u_3 - x_1) + c_{12}(x_2 - x_1)}{mc_{11}} \\ \frac{(-c_{20} - c_{21}u_1)(u_4 - x_2) + c_{12}(x_1 - x_2) + c_{22}(x_3 - x_2) + u_1u_2(c_0 + c_1e^{-c_2x_2} + c_3 \log(u_1 + 1)e^{-c_2x_2}) \frac{P_a}{P_b}^{-0.5}}{mc_{12}} \\ \frac{c_{22}(x_2 - x_3) + c_{30}(x_4 - x_3)}{mc_{13}} \\ \frac{c_{30}(x_3 - x_4) + (c_{40} + c_{41}u_1)(u_4 - x_4)}{mc_{14}} \end{bmatrix} \quad (4)$$

Temperature measurements

Test vehicle

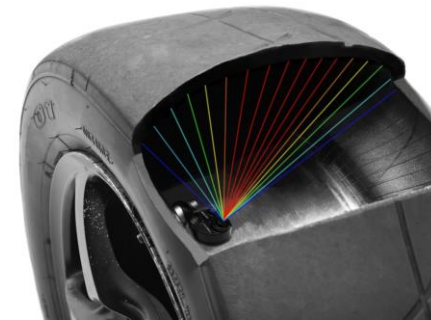

Temperature measurements

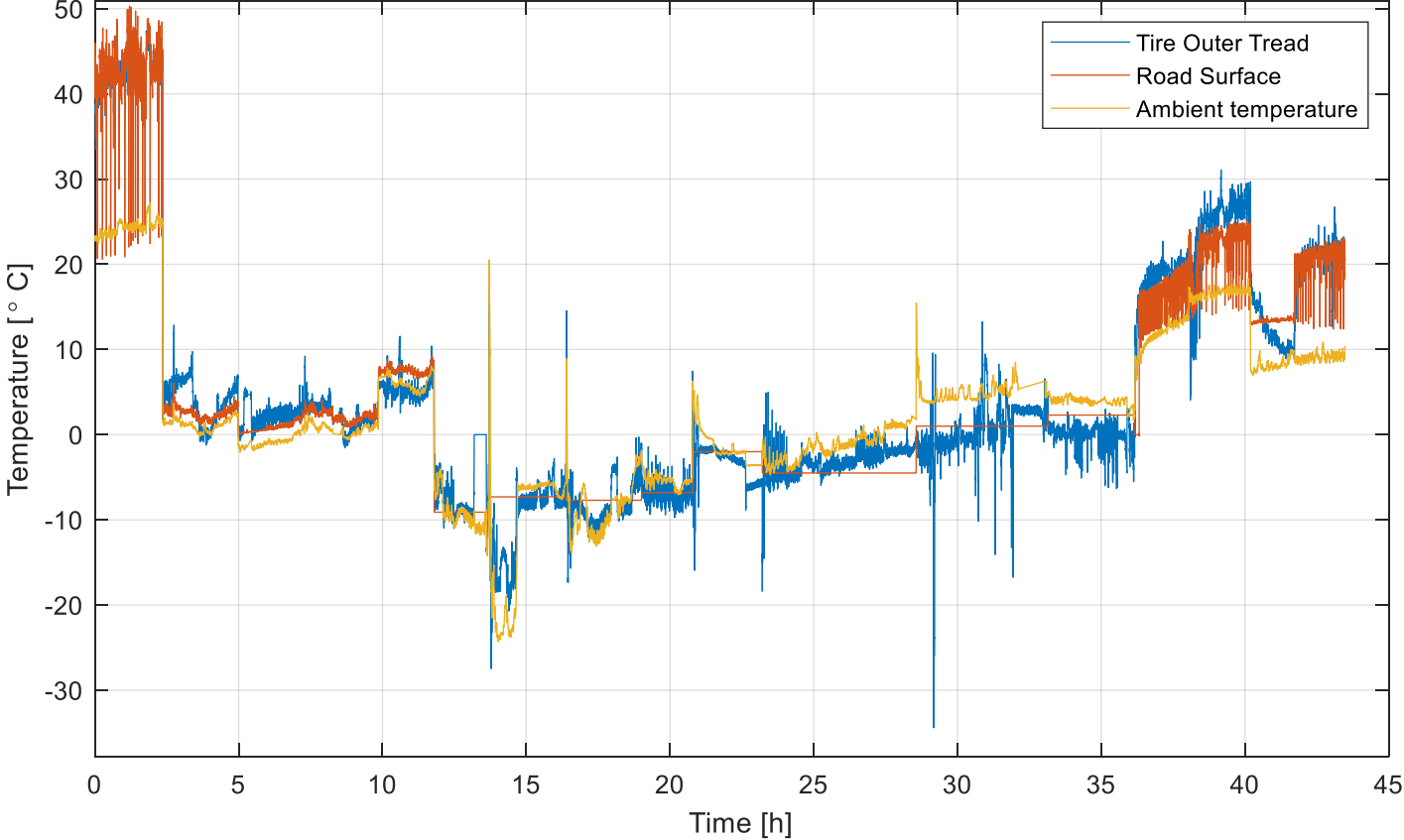

Tire outer tread and road surface temperature

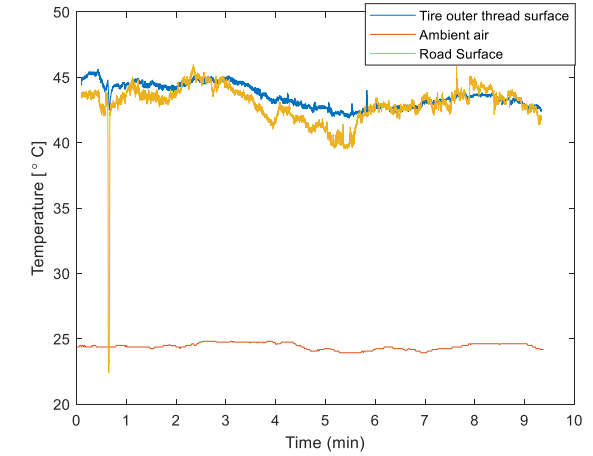
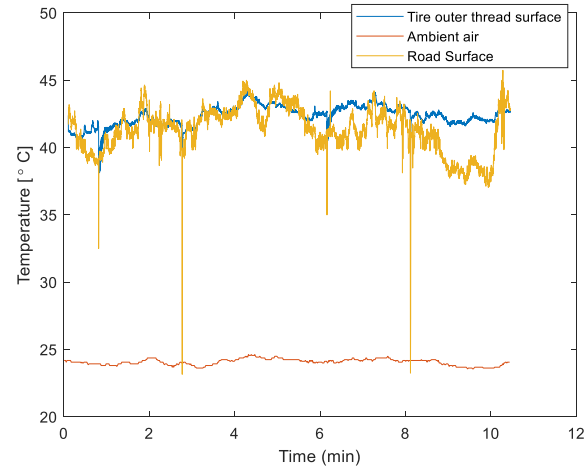
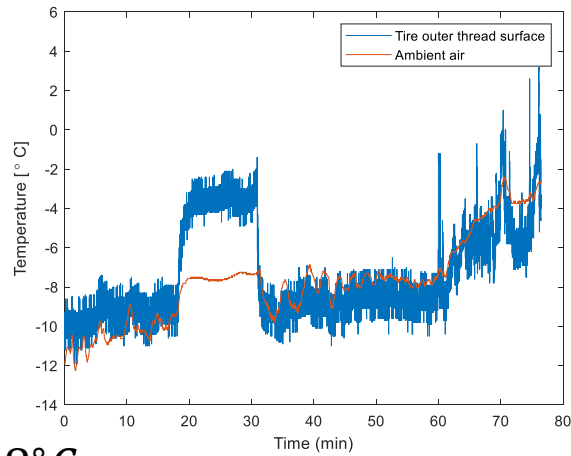

$$T_{RS} \approx -8^{\circ}\text{C}$$

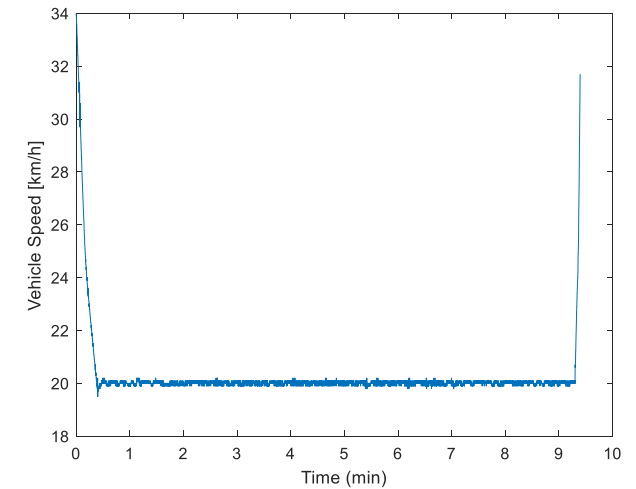
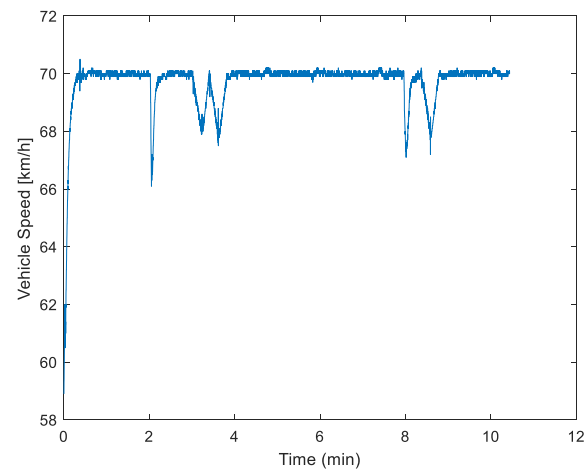
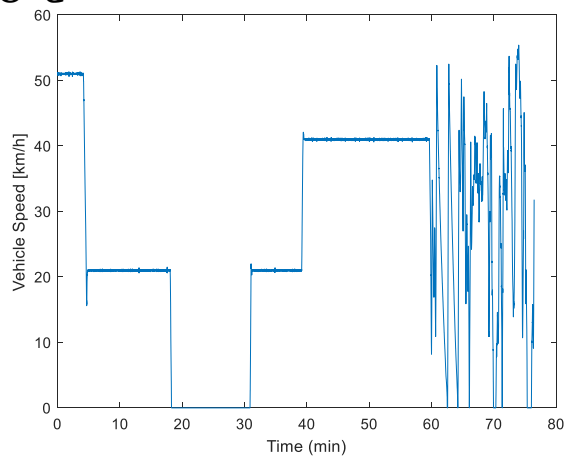

Temperature measurements

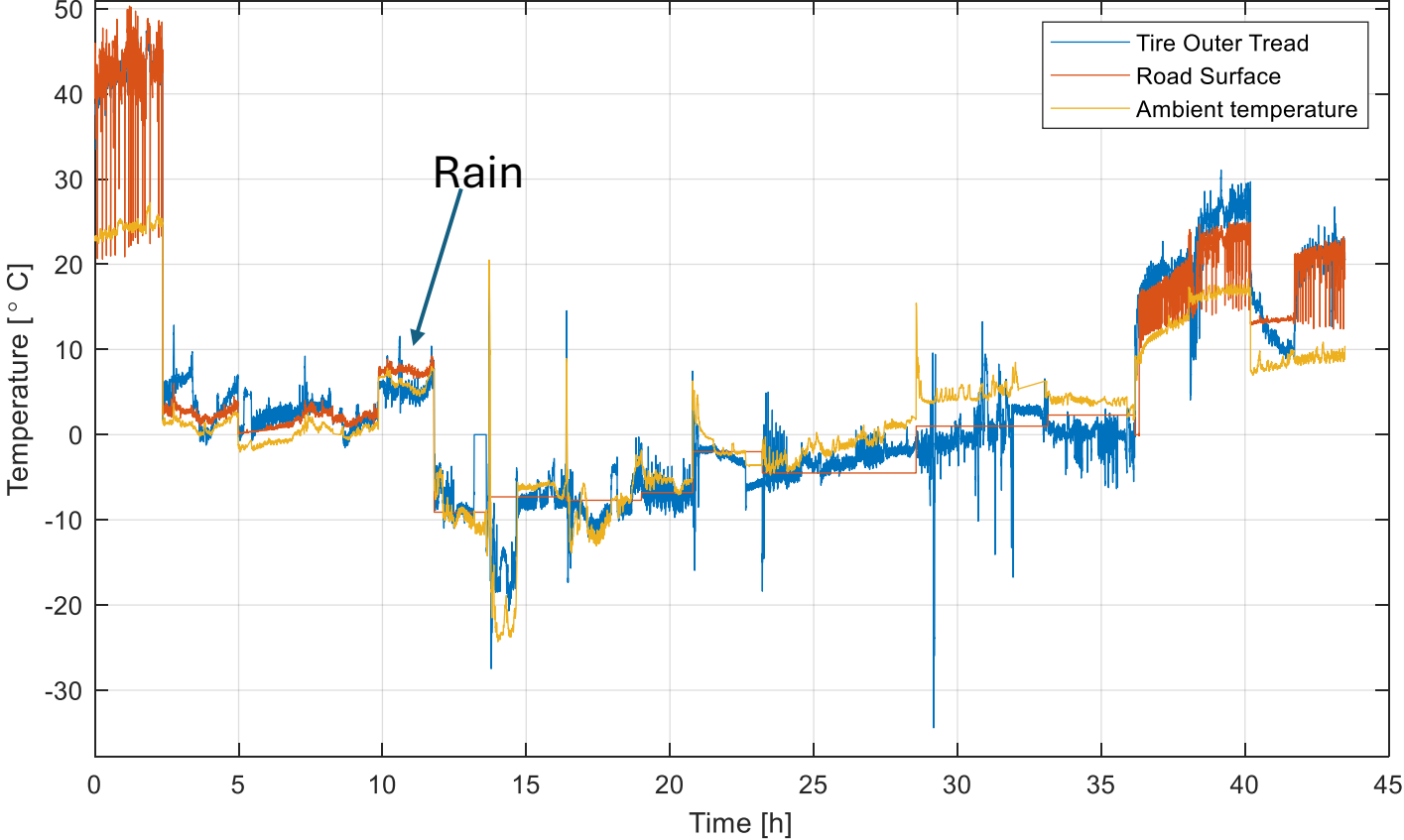

Temperature measurements - Rain

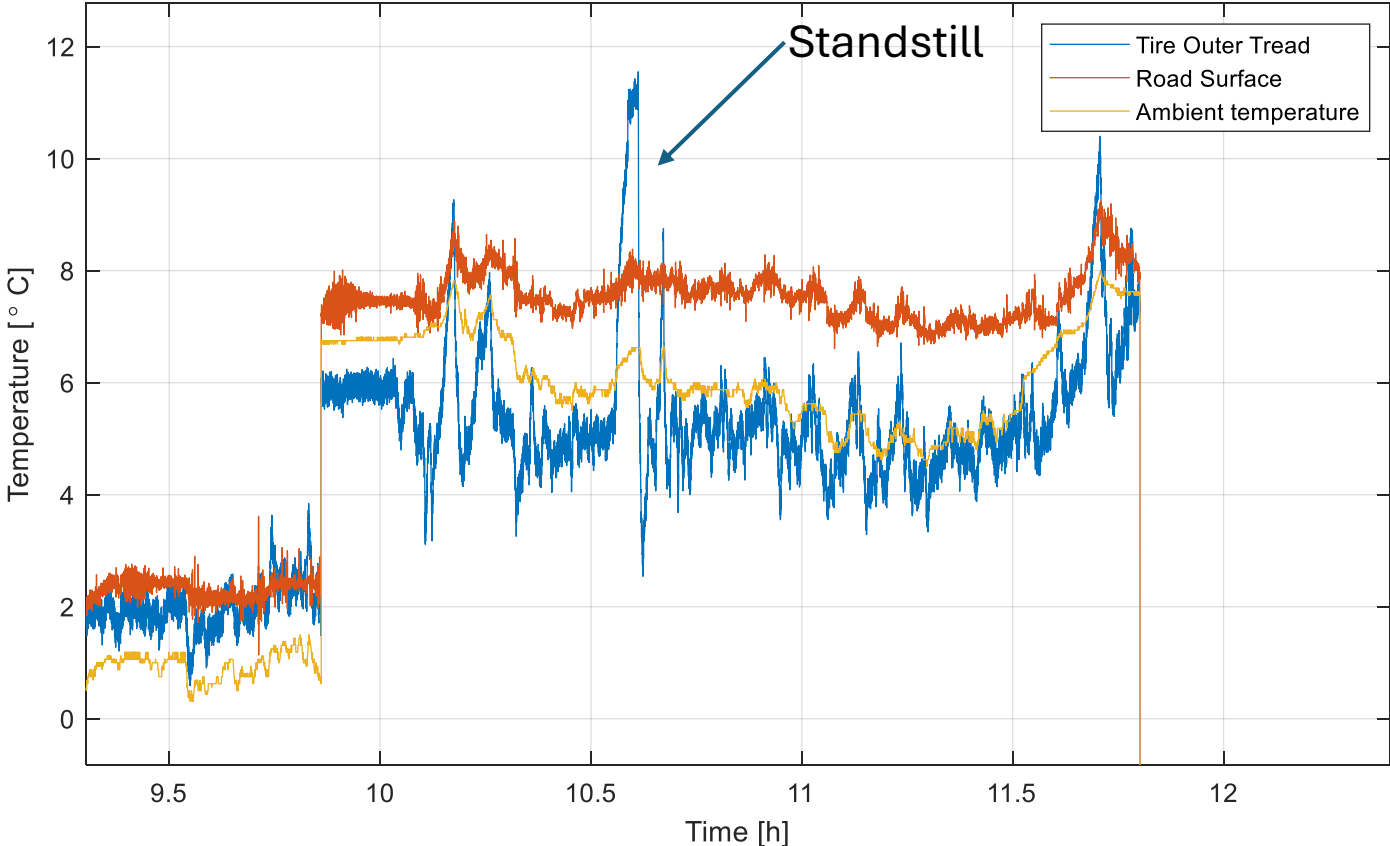

Temperature measurements

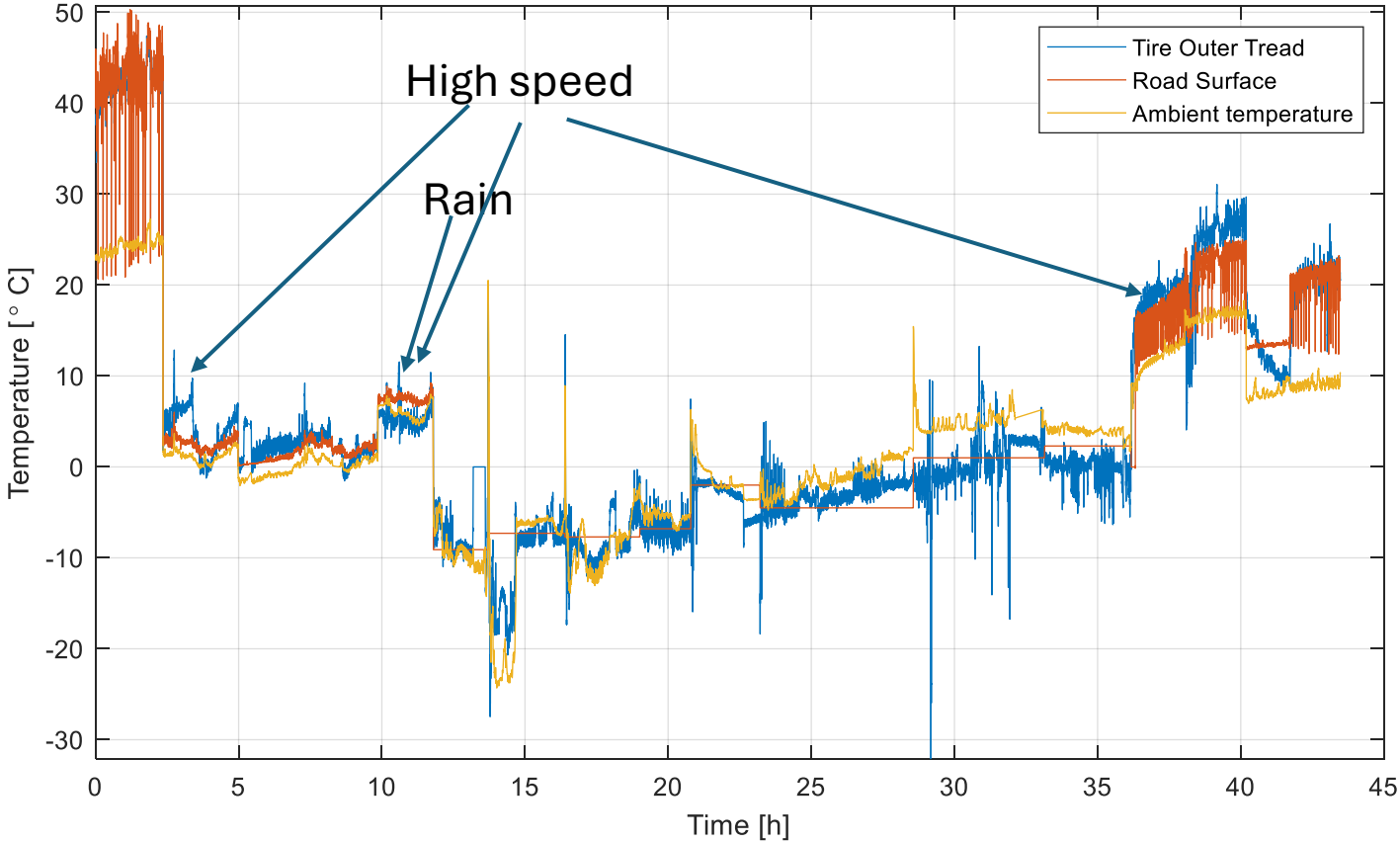

Temperature measurements – High speed

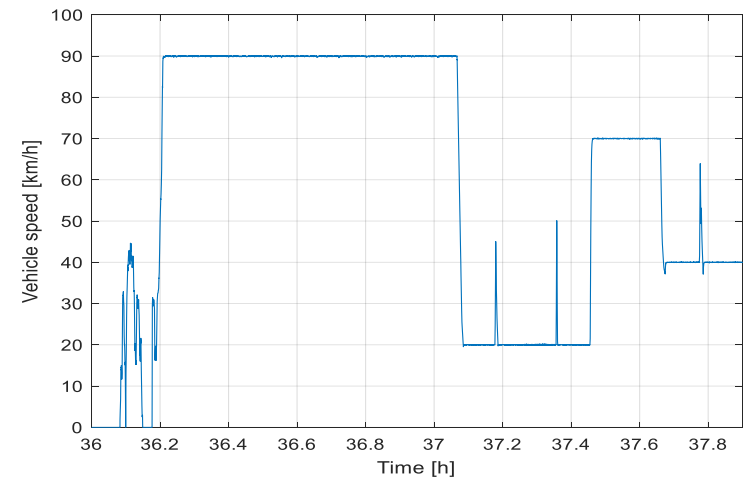
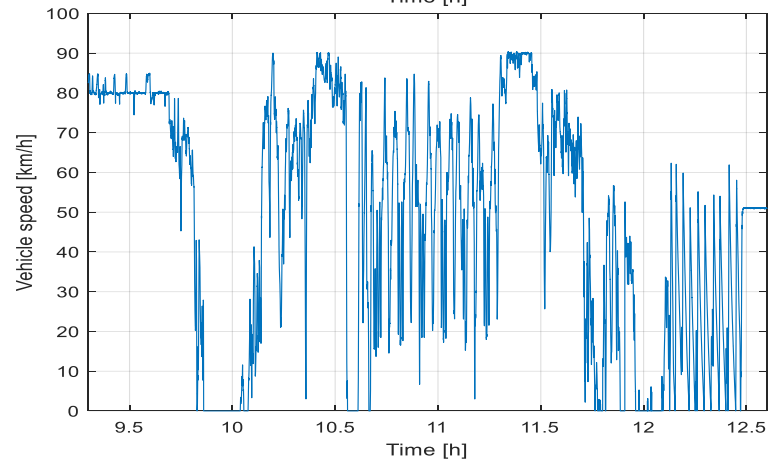
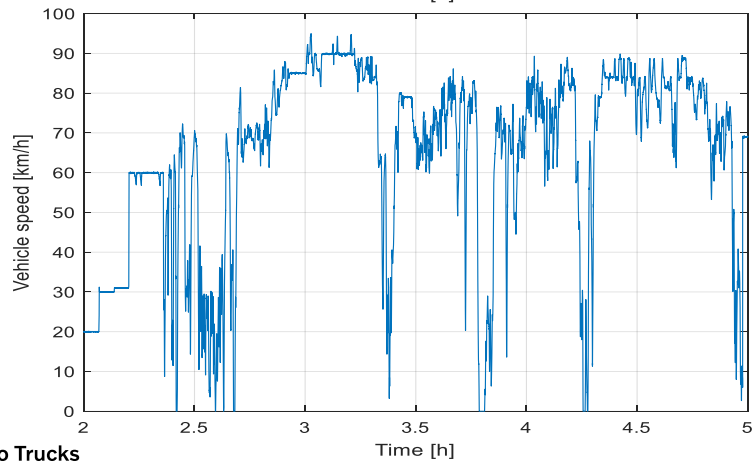
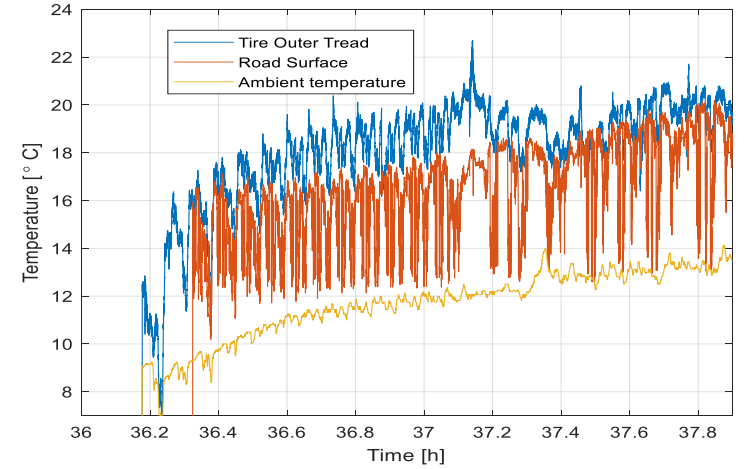
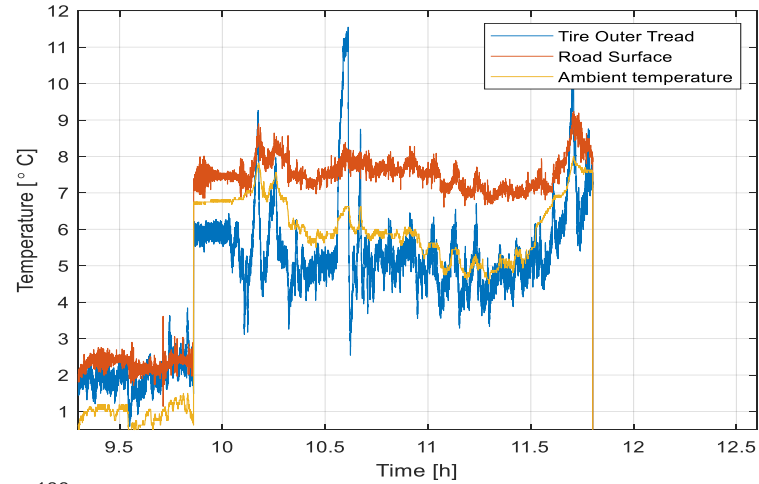
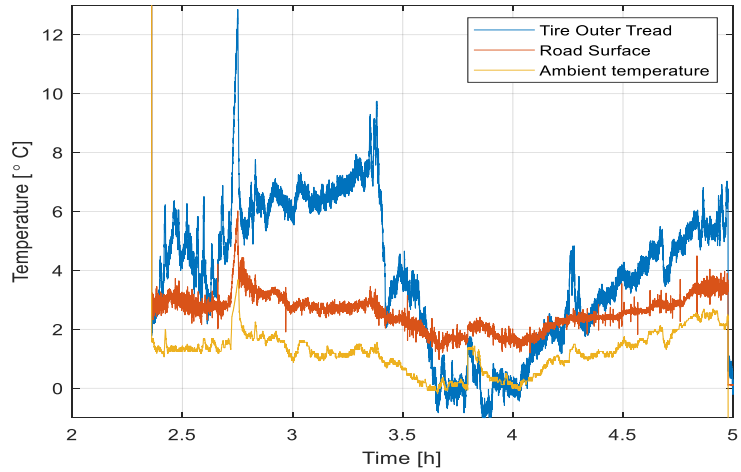

Temperature measurements

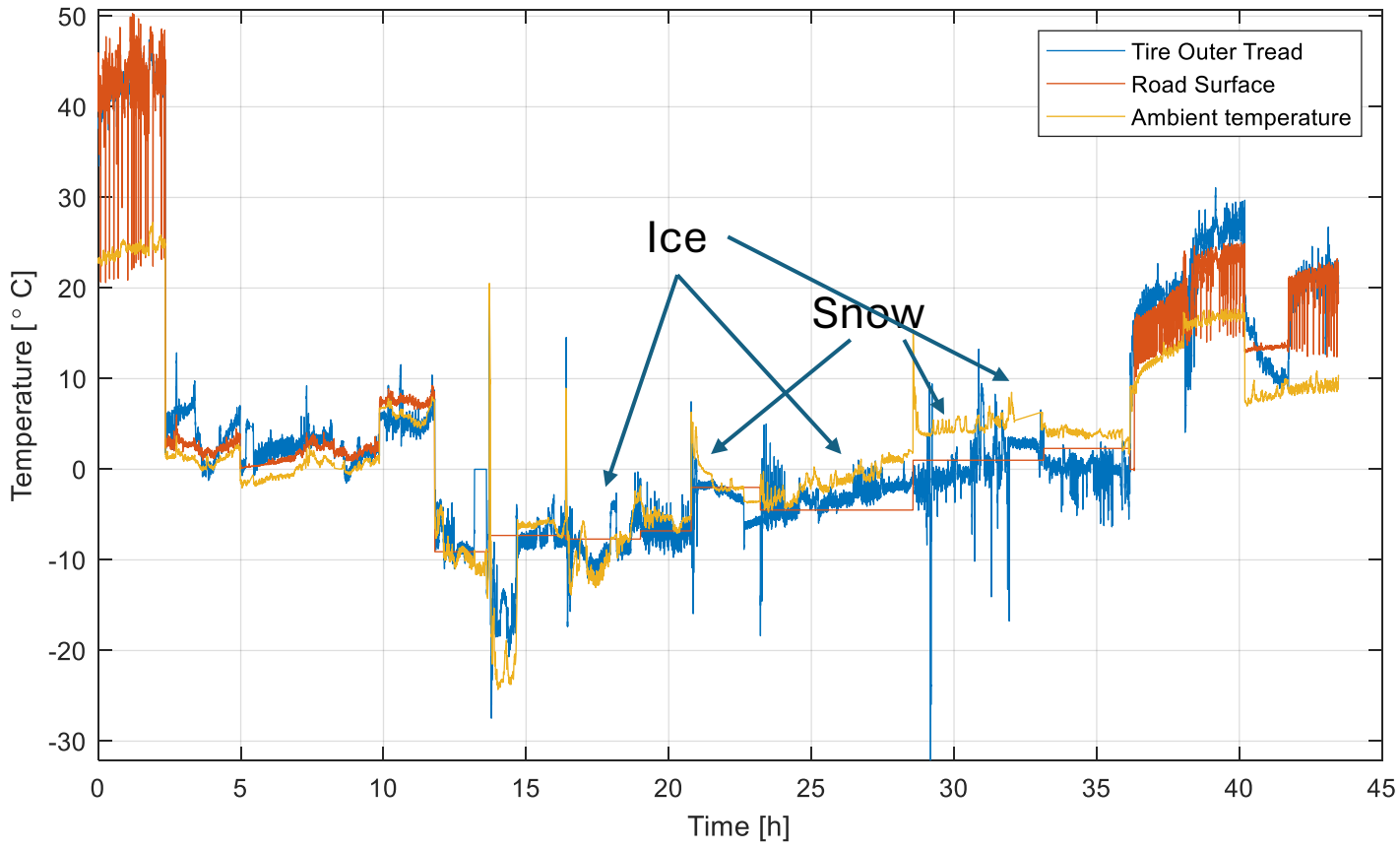

Temperature measurements - Snow

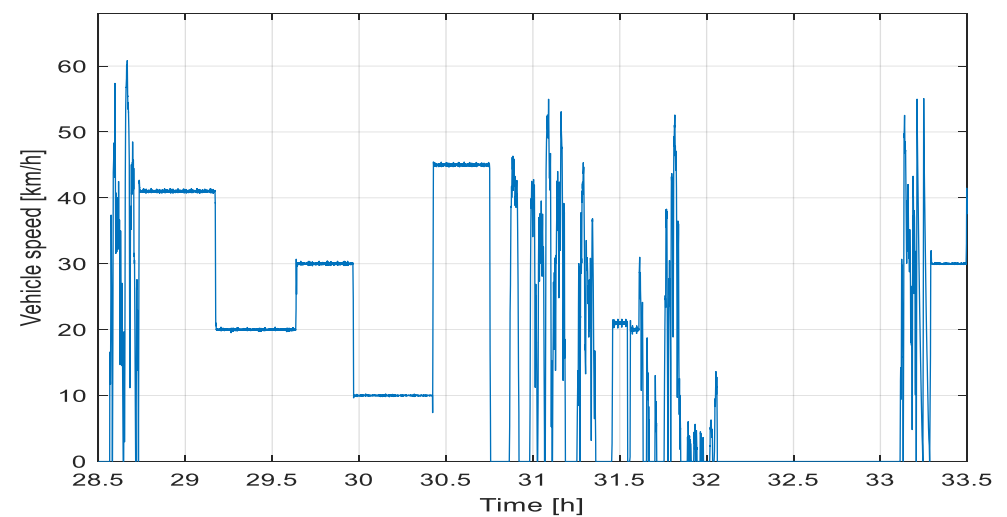
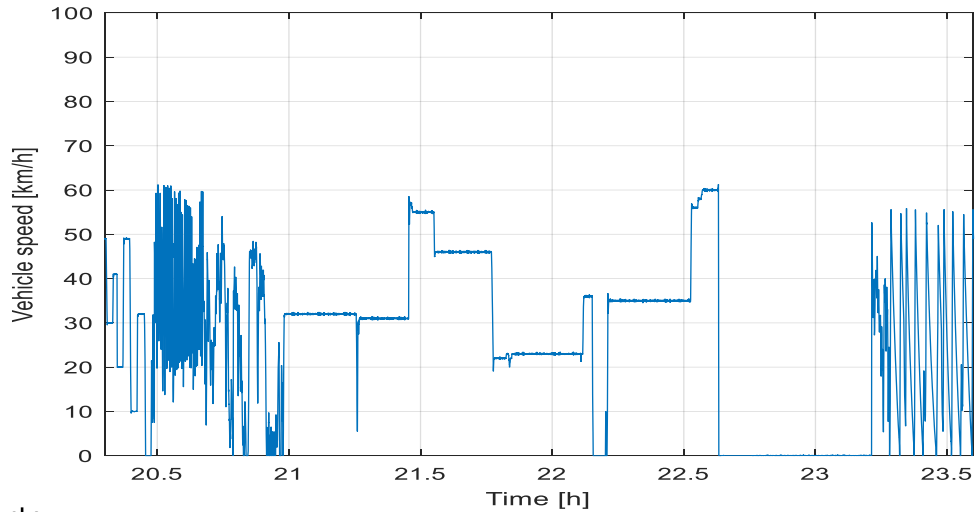
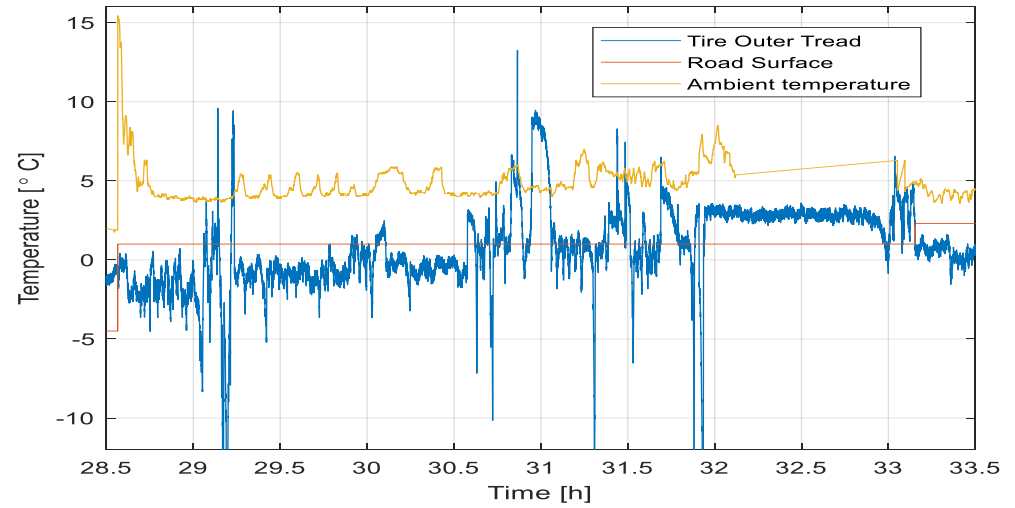
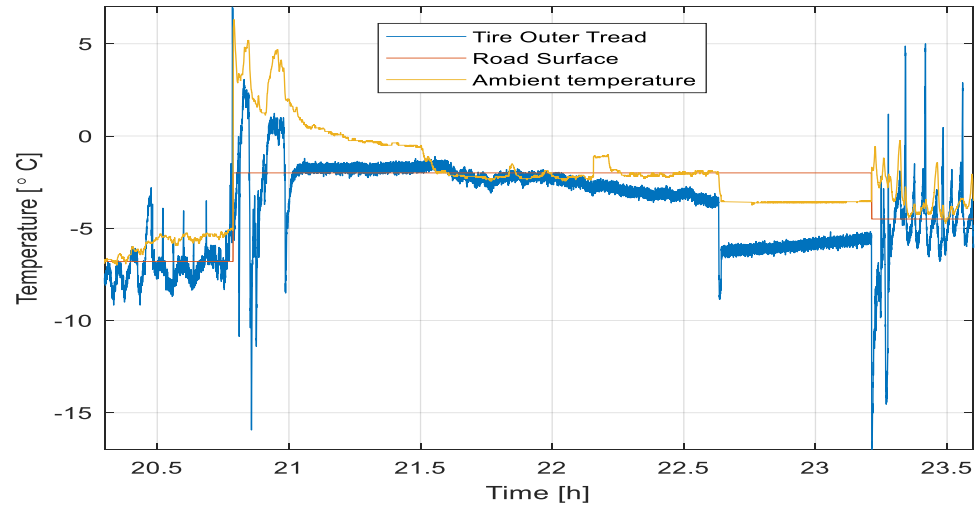

Temperature measurements - Ice

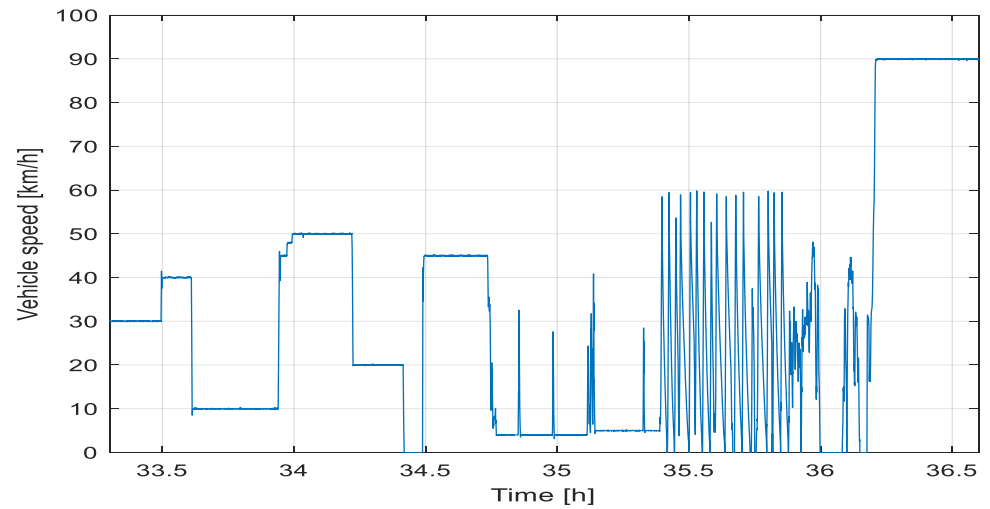
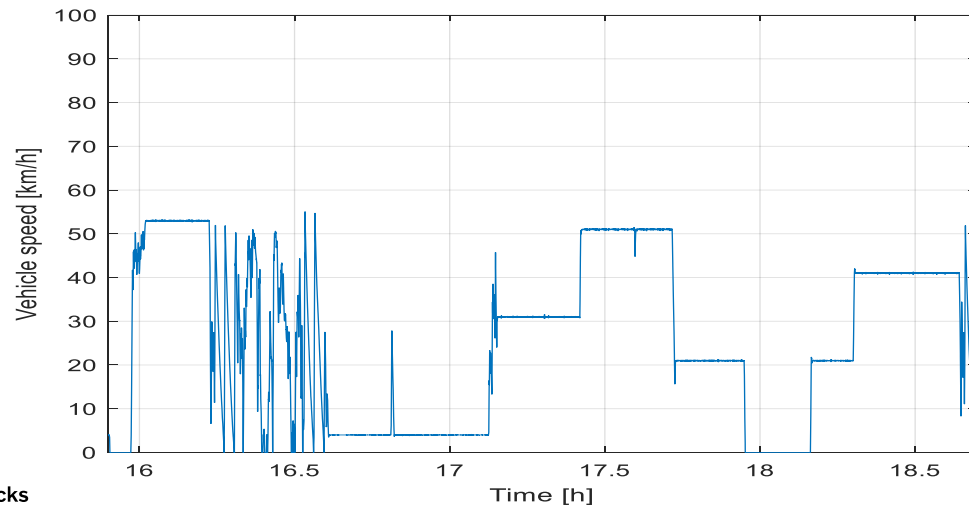
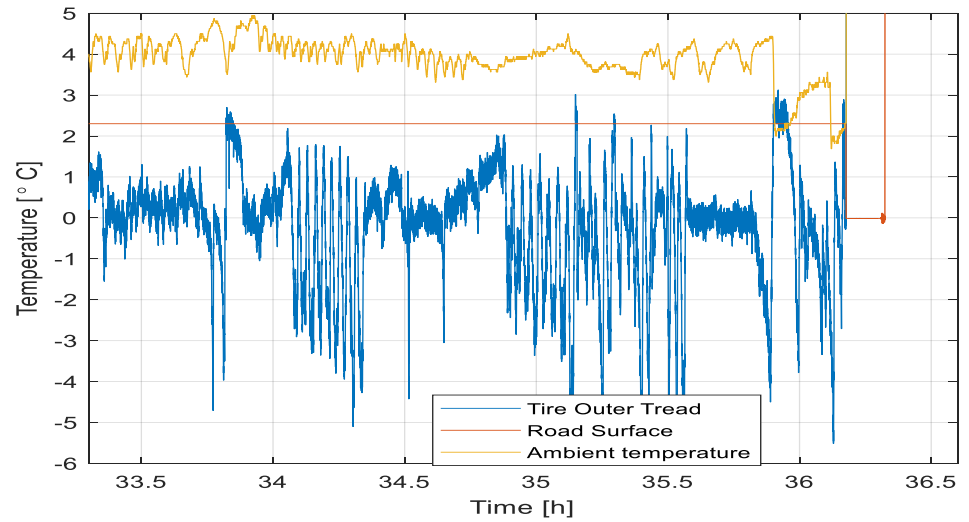
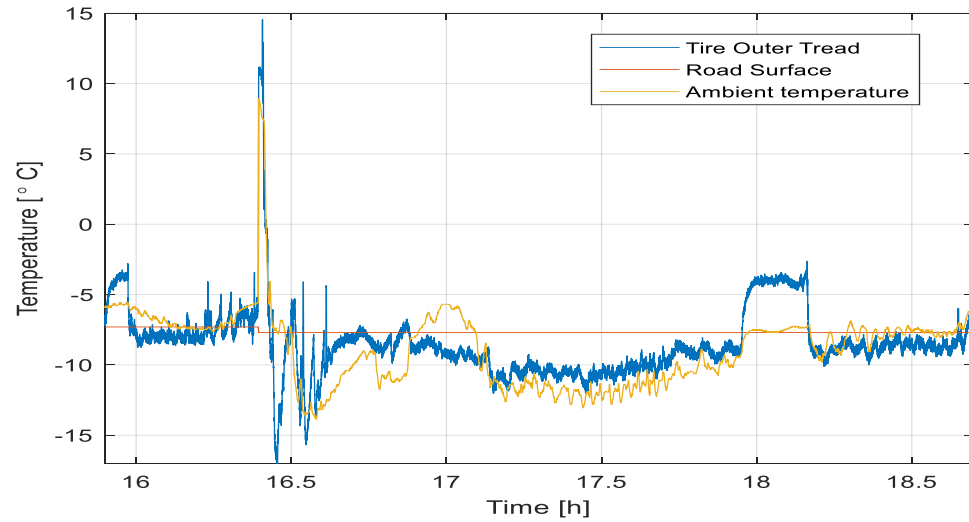

Temperature measurements - Ice

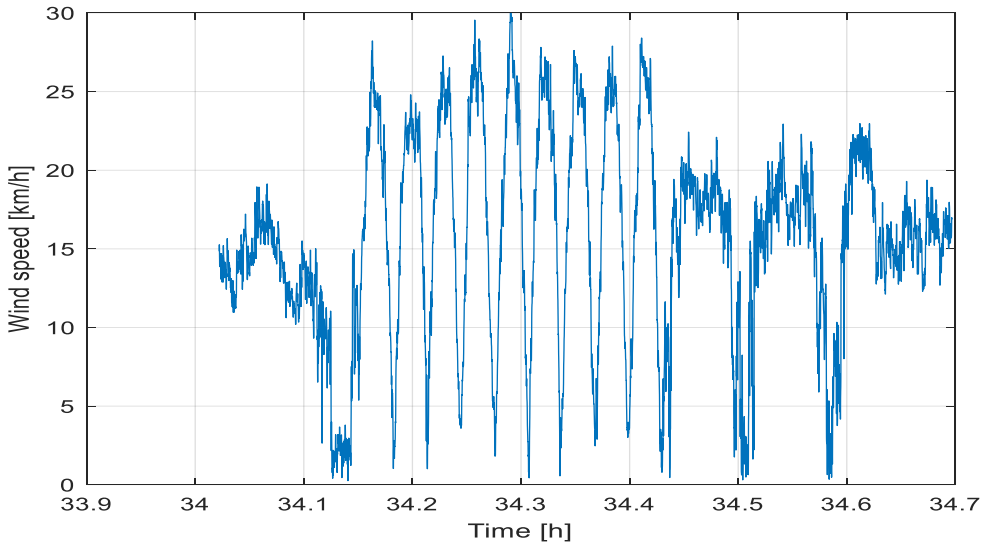
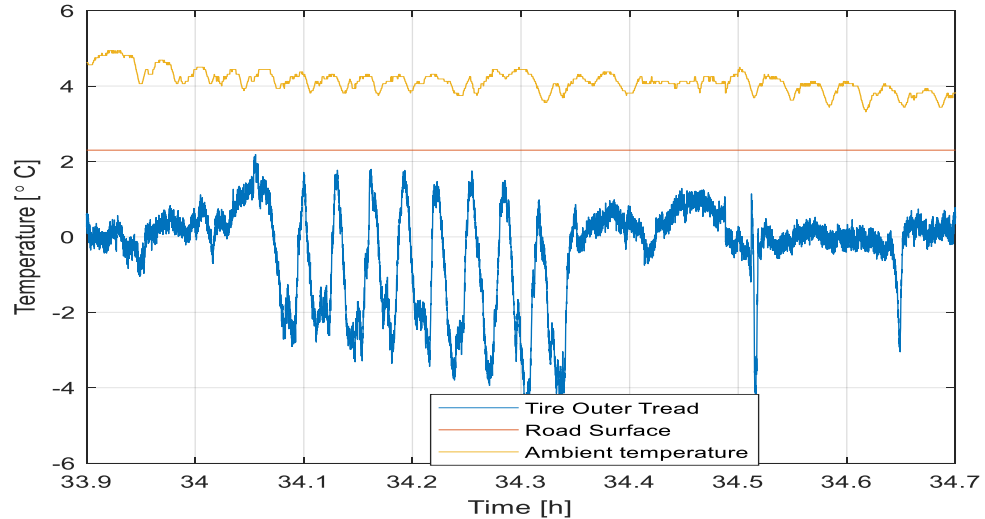

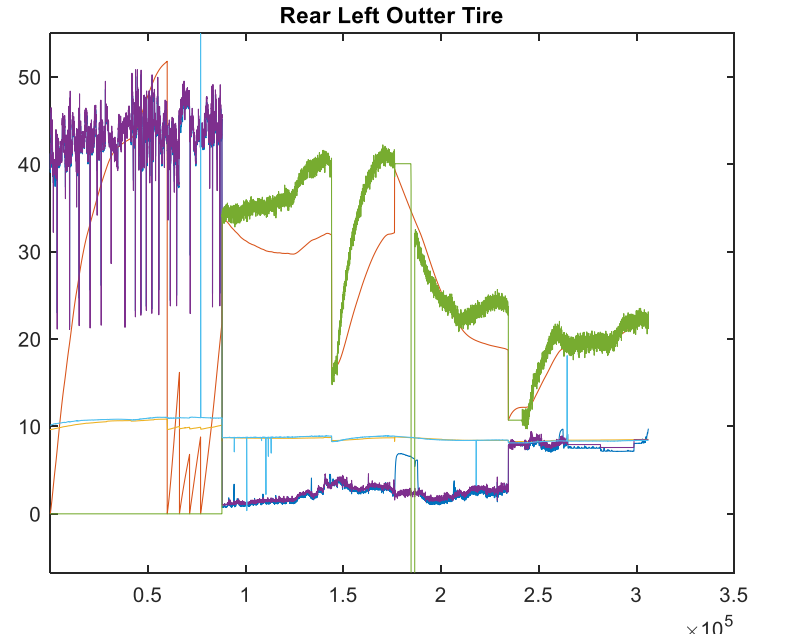
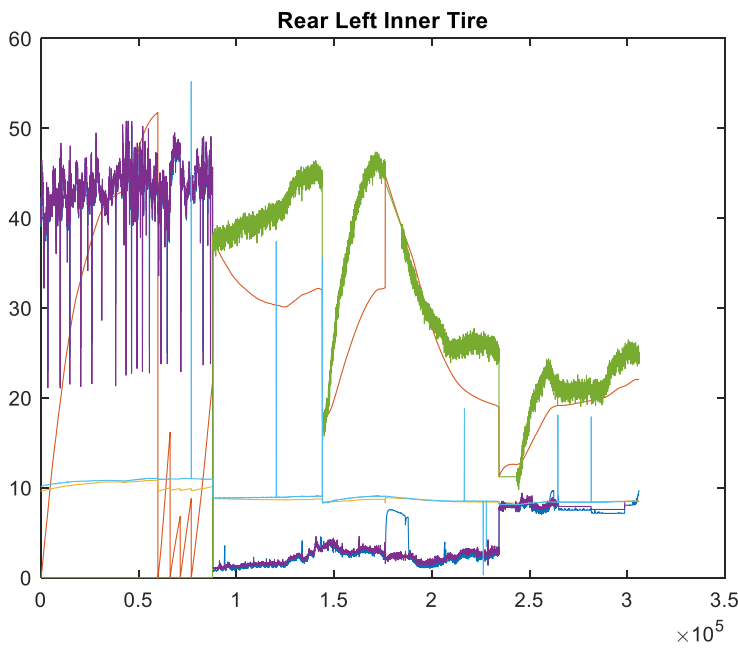
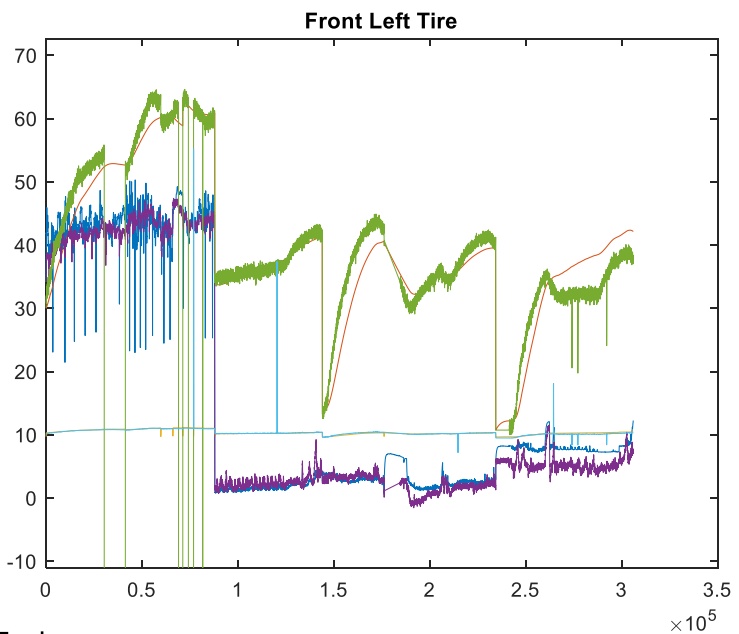
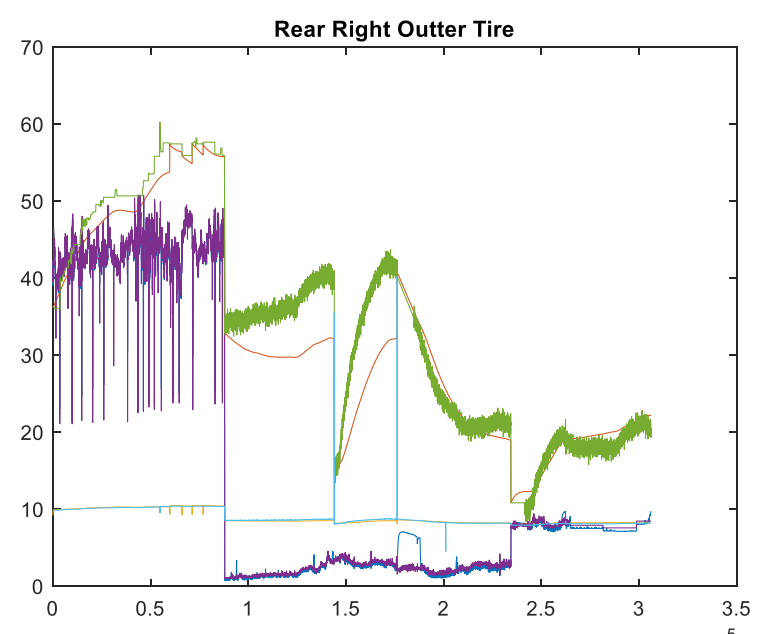
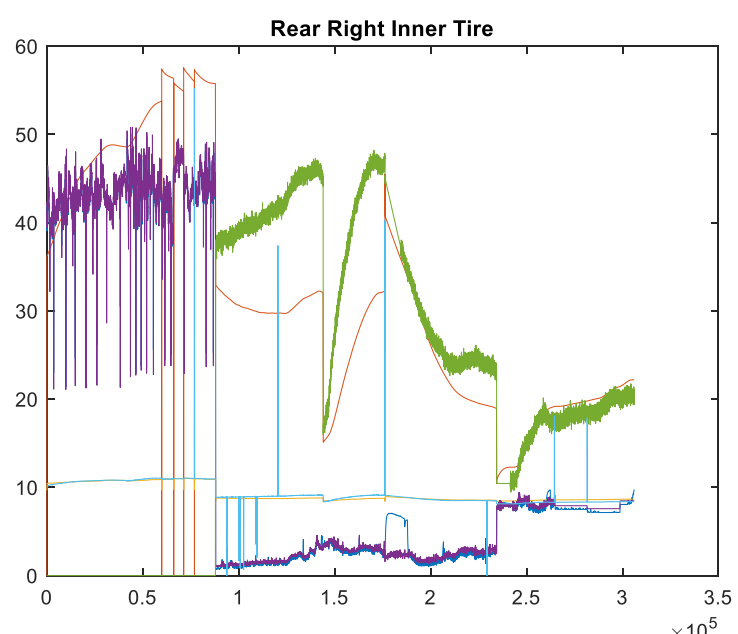
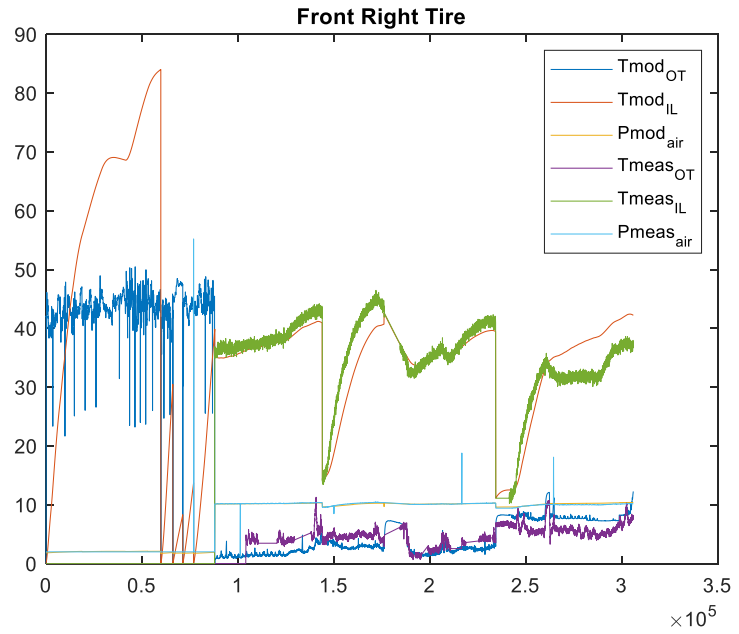

Implications of a linear heat dissipation model

Outer tread temperature model

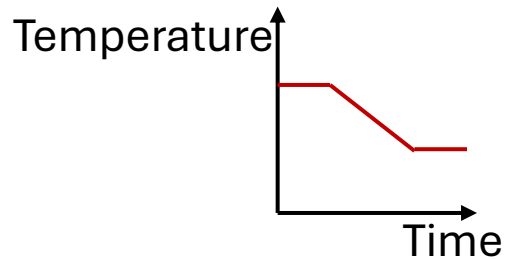
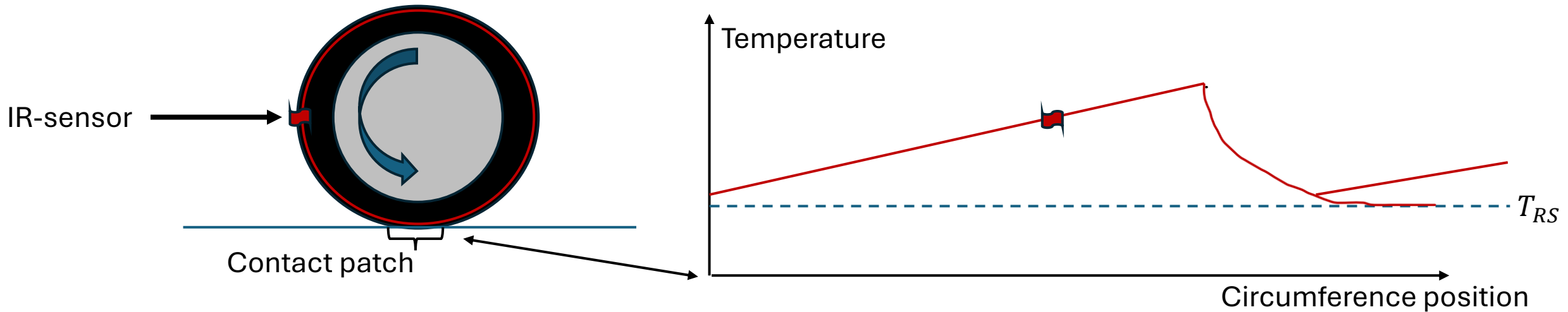

Heat loss in contact patch linear in time ->
 P_{HD} independent of speed

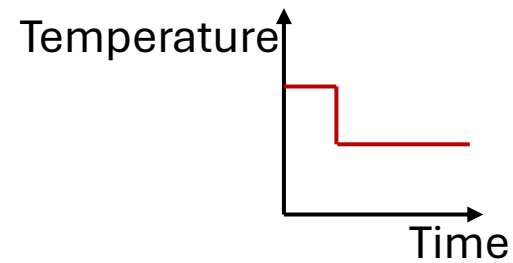

Heat loss in contact patch as step function ->
 P_{HD} linear in speed

A linear heat dissipation model!?

Assumptions based on findings

- Majority of heat is dissipated through contact patch
- Outer tread temperature is independent of (low and moderate) speed and close to road surface temperature
- Tire heat dissipation increases linearly with vehicle speed, i.e. $P_{HD} = f(RS, RSC, \dots)(T_{RS} - T_{OT})v$

A linear heat dissipation model!?

- $P_{in} = F_z c_{rr}(T_t, P_t, v)v$
- Stationary conditions: $P_{in} = P_{HD} \rightarrow$
 $F_z c_{rr} v = f(RS, RSC, \dots)(T_{RS} - T_{OT})v \rightarrow$
$$c_{rr}(T_t, P_t, v) = \frac{f(RS, RSC, \dots)(T_{RS} - T_{OT})}{F_z}$$
- c_{rr} is independent of speed in stationary conditions!
- or equally, if c_{rr} is independent of speed in stationary conditions, then heat dissipation is linear in speed.

Conclusions

- For low and moderate vehicle speeds, tire outer tread temperature tend to be close to road surface temperature
- At high speeds, tread temperature $>$ road surface
- When raining tread temperature $<$ road surface (!)
- A working road surface temperature sensor is needed to understand if above is true when running on snow or ice
- Strong wind may affect tire outer tread temperature
- Stationary rolling resistance independent of speed suggests linear heat dissipation

Thank you!

Presentation 5:
*FMU-based co-simulation for autonomous
vehicle dynamics control*
Wenliang Zhang, KTH



FMU-based co-simulation for autonomous vehicle dynamics control

Wenliang Zhang
Postdoc Researcher
KTH Vehicle Dynamics

May 7, 2025
@SVEA Seminar 2025

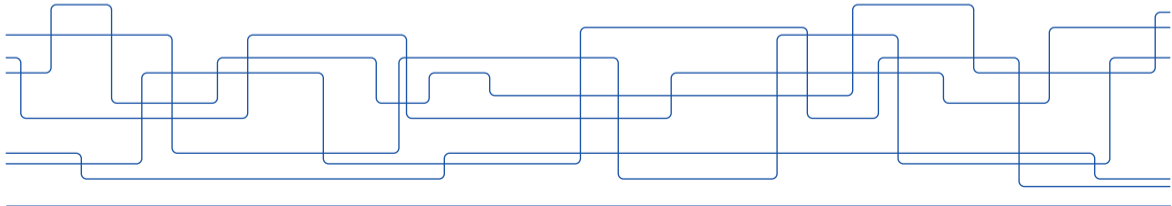



Outline

Background

FMU export

FMU import

Co-simulation

Dynamics control

Conclusions

FMI & FMU

Functional Mock-up Interface (FMI)¹

- ▶ A free standard that defines a container and an interface to exchange dynamic simulation models
- ▶ Uses a combination of XML files, binaries and C code, distributed as a ZIP file



Functional Mock-up Unit (FMU)²

- ▶ A file that contains a simulation model that adheres to the FMI standard

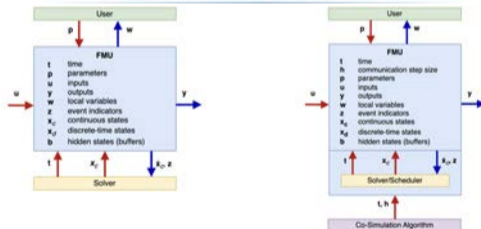

FMI & FMU illustrations. Source: FMI Standard.

¹<https://fmi-standard.org/>.

²<https://modelon.com/blog/functional-mock-up-interface-fmi/>.



FMI tools

Supported by 230+ tools¹

Vehicle	Simulation	Optimisation
CarMaker	Simulink	CasADi
CarSim	Dymola	OPTIMICA Compiler Toolkit
CRUISE	OpenModelica	Optimization Suite

- ▶ Maintained as a Modelica association project

¹<https://fmi-standard.org/tools/>.

FMU-based co-simulation

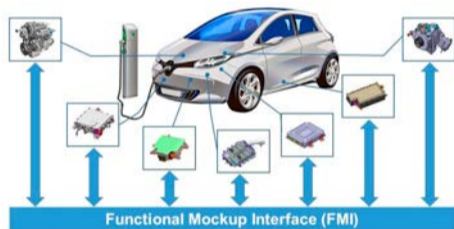

FMU-based co-simulation in vehicle domain.¹

Advantages

- ▶ Exchange models from different tools
- ▶ Easy update and maintain components
- ▶ Improve co-simulation efficiency

¹<https://www.mdpi.com/607960>.

FMU export – Dymola

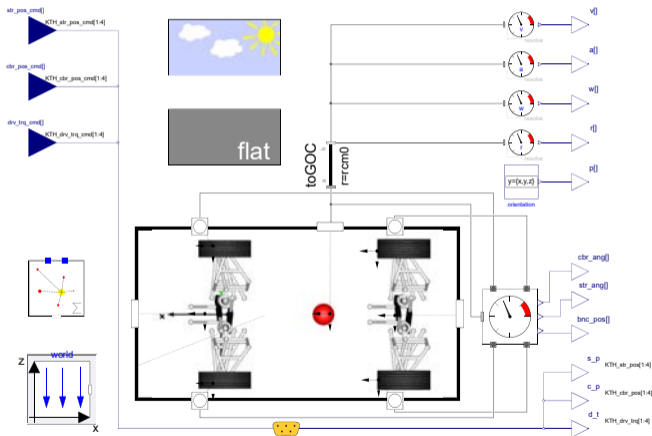

Dymola vehicle plant model.

Model features

- ▶ Over-actuation
 - ▶ Four-wheel drive
 - ▶ Four-wheel steer
 - ▶ Active camber
- ▶ Major components
 - ▶ Double-wishbone suspensions
 - ▶ Pacejka tyre models
 - ▶ Aerodynamics package

FMU features

- ▶ 44 continuous states
- ▶ 57,330 variables

FMU export – Dymola

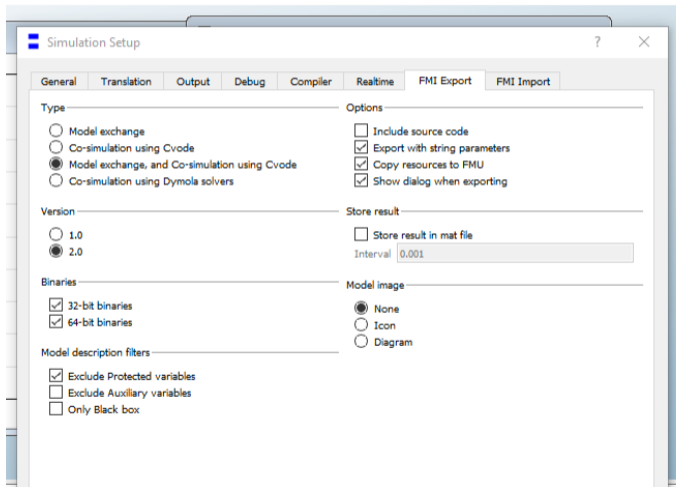

FMI export options in Dymola. Source: Claytex.

FMU export settings

- ▶ FMU type
- ▶ Version
- ▶ Binaries
- ▶ Model description filters

FMU export – Simulink

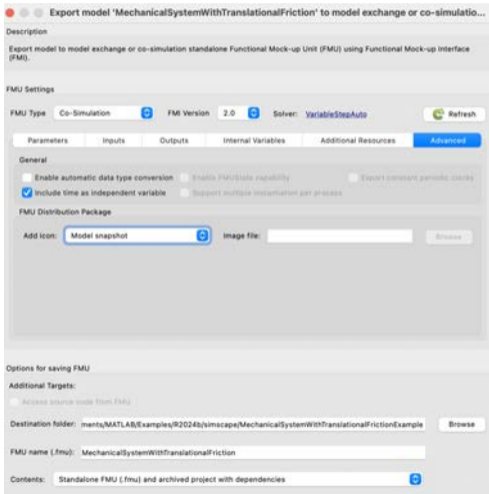

The screenshot shows the 'Export model' dialog box in Simulink. The title bar reads 'Export model 'MechanicalSystemWithTranslationalFriction' to model exchange or co-simulatio...'. The 'Description' section states: 'Export model to model exchange or co-simulation standalone Functional Mock-up Unit (FMU) using Functional Mock-up Interface (FMI)'. The 'FMU Settings' section includes: 'FMU Type' set to 'Co-Simulation', 'FMI Version' set to '2.0', and 'Solver' set to 'VariableStepAuto'. There is a 'Refresh' button. Below this are tabs for 'Parameters', 'Inputs', 'Outputs', 'Internal Variables', 'Additional Resources', and 'Advanced'. The 'Advanced' tab is selected, showing 'General' options: 'Enable automatic data type conversion' (unchecked), 'Enable FMUState capability' (unchecked), 'Export constant periods/clocks' (unchecked), 'Include time as independent variable' (checked), and 'Support multiple instants/initial per process' (unchecked). The 'FMU Distribution Package' section has 'Add icon' set to 'Model snapshot' and an empty 'Image file' field. The 'Options for saving FMU' section includes 'Additional Targets' (unchecked), 'Destination folder' set to 'ments\MATLAB\Examples\R2024b\simulink\MechanicalSystemWithTranslationalFrictionExample', 'FMU name (.fmu)' set to 'MechanicalSystemWithTranslationalFriction', and 'Contents' set to 'Standalone FMU (.fmu) and archived project with dependencies'.

FMU export options in Simulink.

FMU import settings

- ▶ FMU type
- ▶ Version
- ▶ Solver



FMU export – Result

RCV.fmu exported from Dymola

```

binaries/
  win32/
    RCV.fmu
  win64/
    RCV.fmu
modelDescription.xml
  
```

modelDescription.xml

```

1  <?xml version="1.0" encoding="UTF-8"?>
2  <fmiModelDescription
3      modelName="RCV"
4      description="Research Concept Vehicle wi
5      ...
6      <UnitDefinitions>
7          ...
8      </UnitDefinitions>
9      <ModelVariables>
10         ...
11     </ModelVariables>
12     <ModelStructure>
13         ...
14     </ModelStructure>
15     ...
16 </fmiModelDescription>
  
```



FMU export - Summary

FMU types

- ▶ Model exchange
- ▶ Co-simulation

Solver settings

- ▶ Internal solvers
 - ▶ CVODE
 - ▶ Dymola solver
 - ▶ Simulink solvers
- ▶ External solvers
 - ▶ Simulation environment dependent

Model settings

- ▶ Configure input and output ports
- ▶ Expose signals for inspection
- ▶ Allow updating parameters

Other options

- ▶ Binaries
- ▶ Source code
- ▶ Model description filters

FMU import – CarMaker

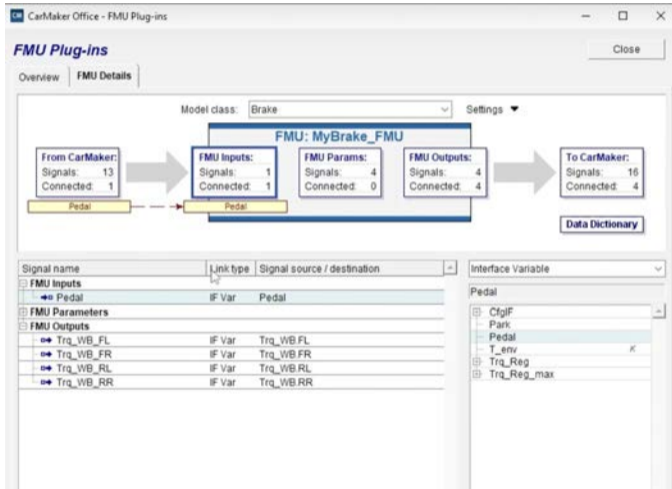

FMU import signals

- ▶ Inputs
- ▶ Outputs
- ▶ Parameters

FMU details in CarMaker. Source: IPG Automotive.

FMU import – Simulink

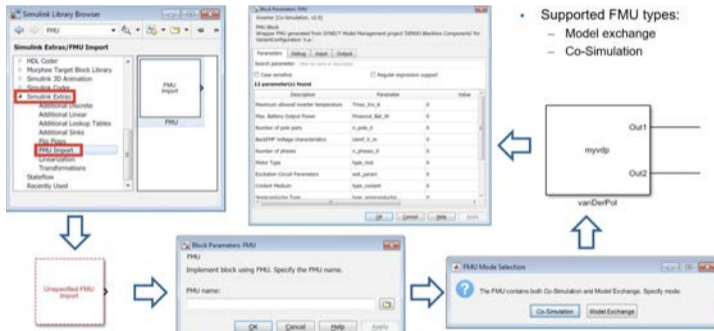

Supported FMU types:

- Model exchange
- Co-Simulation

FMU import steps

- ▶ Add FMU block
- ▶ Load FMU file
- ▶ Select FMU type
- ▶ Configure FMU details

FMU import in Simulink. Source: MathWorks.



FMU import – FMPy

```
from fmpy import read_model_description, extract
from fmpy.fmi2 import FMU2Slave
from fmpy.simulation import apply_start_values
...
# Read model description
rcvfm_description = read_model_description(rcvfm_file)
# Collect variable references
rcv_variables = {}
for variable in rcvfm_description.modelVariables:
    rcv_variables[variable.name] = variable.valueReference
...
# Extract FMU
rcvfm_unzipdir = extract(rcvfm_file)
...
# Initialize
rcvfm.instantiate()
rcvfm.setupExperiment(startTime=rcvfm_starttime)
apply_start_values(rcvfm, rcvfm_description,
    start_values={'v_start': vxin0})
...
```

FMU import & setup

- ▶ Load FMU file
- ▶ Collect variables
- ▶ Initialise start time, initial states, etc.



FMU import - Summary

Solver settings

- ▶ Internal solvers
 - ▶ CVODE
 - ▶ Dymola solver
 - ▶ Simulink solvers
- ▶ External solvers
 - ▶ Simulation environment dependent

Model settings

- ▶ Configure input & output ports
- ▶ Extract signals for inspection
- ▶ Initialise model
 - ▶ Parameters: Road friction, sampling interval
 - ▶ States: Velocity, position



Co-simulation framework

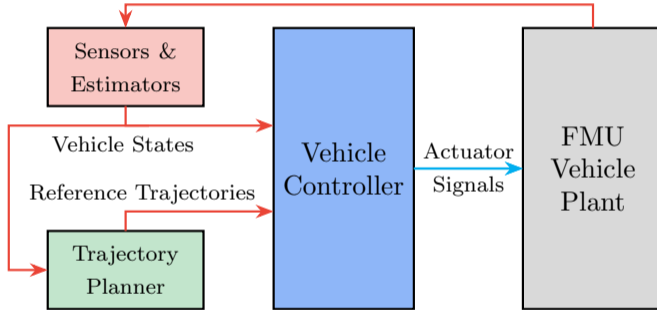

FMU-based co-simulation framework¹.

Framework components

- ▶ Autonomous driving
 - ▶ Perception
 - ▶ Planning
 - ▶ Control
- ▶ FMU vehicle

¹W. Zhang, 'Exploiting over-actuation for improved active safety of autonomous electric vehicles', PhD Thesis, KTH, 2022.

Co-simulation toolchain

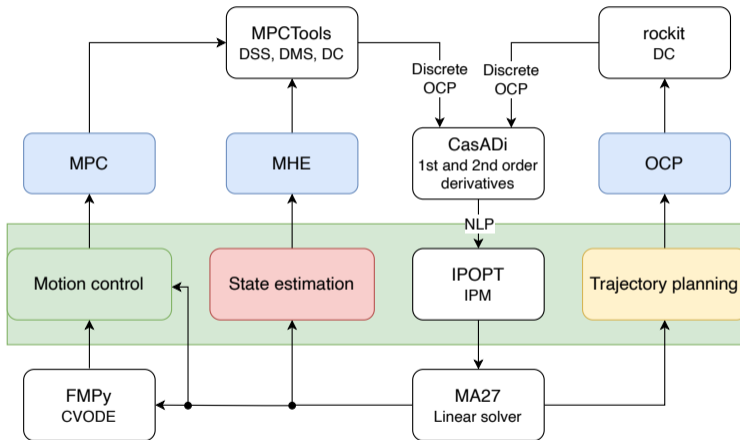

FMU-based co-simulation toolchain².

²W. Zhang, 'Exploiting over-actuation for improved active safety of autonomous electric vehicles', PhD Thesis, KTH, 2022.



Control objective

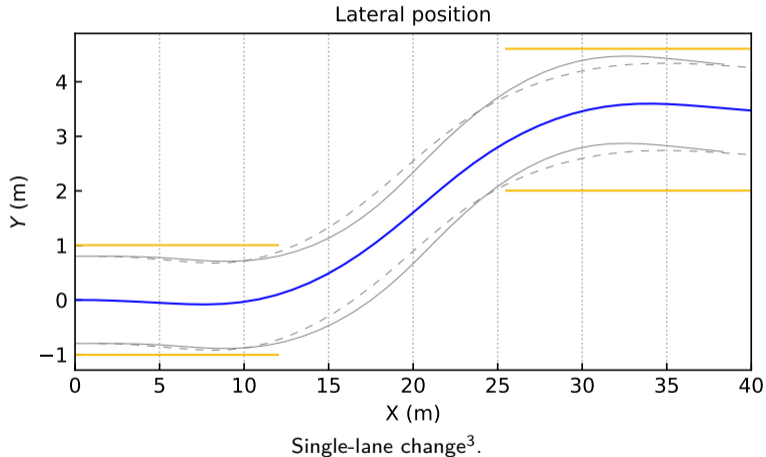

³W. Zhang, L. Drugge, M. Nybacka, and J. Jerrelind, 'Integrated Control of Motion Actuators for Enhancing Path Following and Yaw Stability of Over-Actuated Autonomous Vehicles', *Energies*, vol. 16, no. 12, Art. no. 12, Jan. 2023, doi: 10.3390/en16124776.



MPC controller

Cost function:

$$\begin{aligned}
 \min_{\mathbf{x}, \mathbf{x}_c, \mathbf{u}, \Delta \mathbf{u}, \mathbf{s}} & \underbrace{\sum_{p=0}^{N-1} \|y_{k+p|k} - y_{k+p|k}^{ref}\|_{Q_y}^2}_{\text{tracking error}} + \underbrace{\sum_{p=0}^{N-1} \|u_{k+p|k}\|_{R_u}^2}_{\text{control action}} \\
 & + \underbrace{\sum_{p=0}^{N-1} \|\Delta u_{k+p|k}\|_{R_{du}}^2}_{\text{change of control action}} + \underbrace{\sum_{p=0}^{N-1} \|s_{k+p|k}\|_{Q_s}^2}_{\text{slack term}} \\
 & + \underbrace{\|y_{k+N|k} - y_{k+N|k}\|_{Q_{yf}}^2}_{\text{terminal cost of tracking error}} + \underbrace{\|s_{k+N|k}\|_{Q_{sf}}^2}_{\text{terminal cost of slack variable}}
 \end{aligned}$$

Constraints:

State equation

Control constraints

State constraints



Co-simulation & Dynamics control

```

...
# Pass references
for i in range(t, t + Nt):
    i = i % Nt
    mpcsolver.par["x_sp", i] = xref[i, :]
mpcsolver.par["x_sp", Nt] = xref[Nt, :]
...
# Solve MPC
mpcsolver.solve()
uu[t, :] = np.squeeze(mpcsolver.var["u", 0])
...
# FMU model simulation
rcvfmui.setReal(rcvfmui_steer,
                [[uu[t, 0], uu[t, 0], 0, 0]])
rcvfmui.setReal(rcvfmui_torque,
                [[uu[t, 1], uu[t, 2], uu[t, 3], uu[t, 4]])
rcvfmui.setReal(rcvfmui_camber, [
                uu[t, 5], uu[t, 5], uu[t, 6], uu[t, 6]])
# Perform one step
rcvfmui.doStep(currentCommunicationPoint=time,
                communicationStepSize=rcvfmui_stepsize)

```

Co-simulation steps via FMPy

- ▶ Update reference signals to MPC
- ▶ Solve MPC and get solutions
- ▶ Pass control signals to FMU model
- ▶ Simulate FMU model by one step

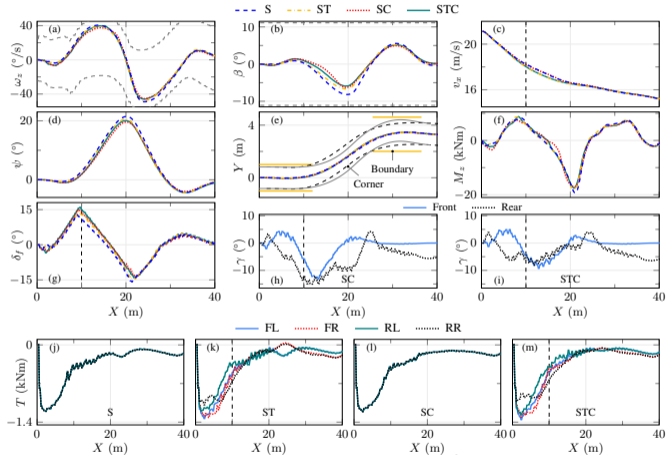

Results

Trajectory tracking results⁴.

⁴W. Zhang, L. Drugge, M. Nybacka, and J. Jerrelind, 'Integrated Control of Motion Actuators for Enhancing Path Following and Yaw Stability of Over-Actuated Autonomous Vehicles', *Energies*, vol. 16, no. 12, Art. no. 12, Jan. 2023, doi: 10.3390/en16124776.



Takeaways

- ▶ FMI & FMU \uparrow Model exchange & Maintenance & Co-simulation efficiency
- ▶ FMI & FMU \rightarrow Model Export & Import for various tools
 - ▶ Dymola & Simulink
 - ▶ CarMaker & CarSim
- ▶ FMI & FMU \rightarrow Customised Solver & Model settings
- ▶ FMU \rightarrow Co-simulation framework & Toolchain
- ▶ FMU-based co-simulation \uparrow AV Dynamics control & Algorithm development



Thank you for listening!

For further questions, welcome to contact me via

 wez@kth.se

 <https://www.researchgate.net/profile/Wenliang-Zhang-3>

 <https://www.linkedin.com/in/wenliang-zhang-124144243>

Presentation 6:

***Braking Distance Minimization on Roads
with Varying Friction***

Ektor Karyotakis, Volvo Cars and Chalmers

Braking Distance Minimization on Roads with Varying Friction



Licentiate seminar, Ektor Karyotakis

2025.05.09

Loss of vehicle control (skidding) increases with bad weather/road condition (NHTSA; 2020—2022)

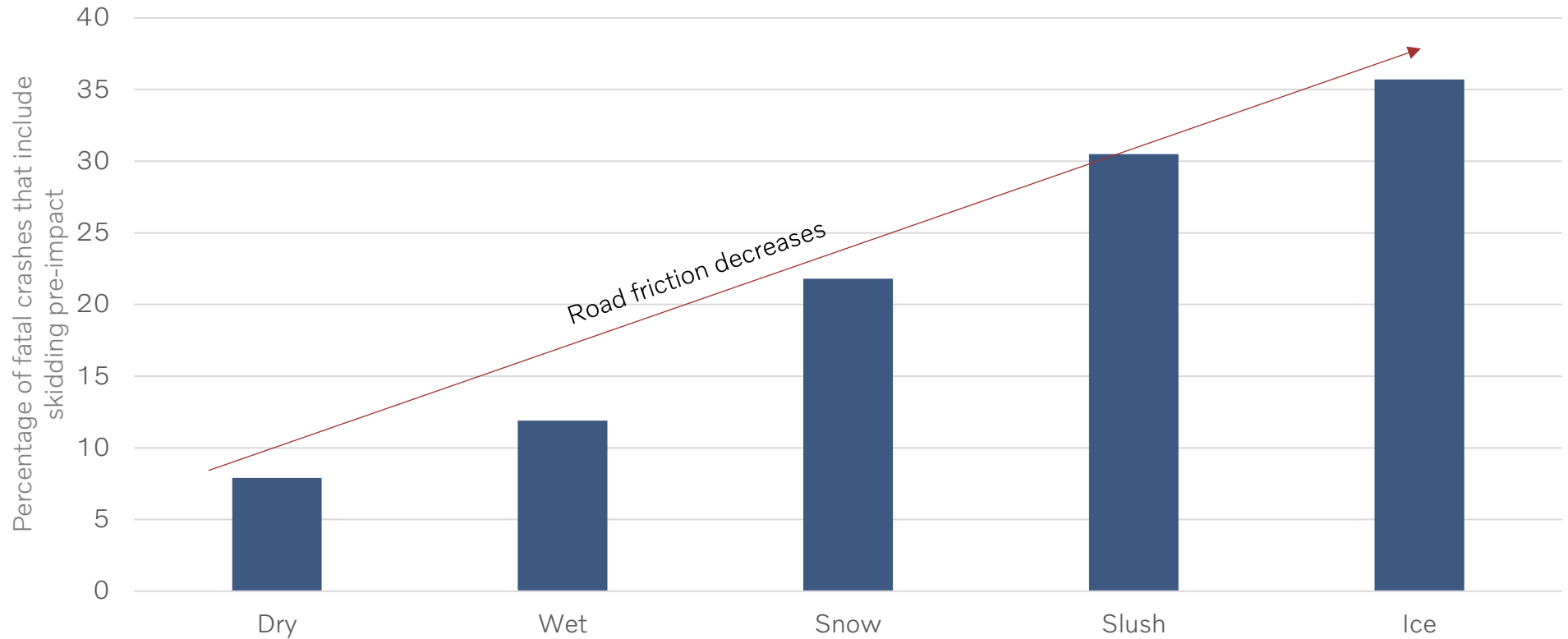

1. Better systems at low frictions
2. Current safety systems assume dry asphalt and sunny weather
3. Difficult to predict road friction

Road friction information

- Tyre as a sensor



Too late?

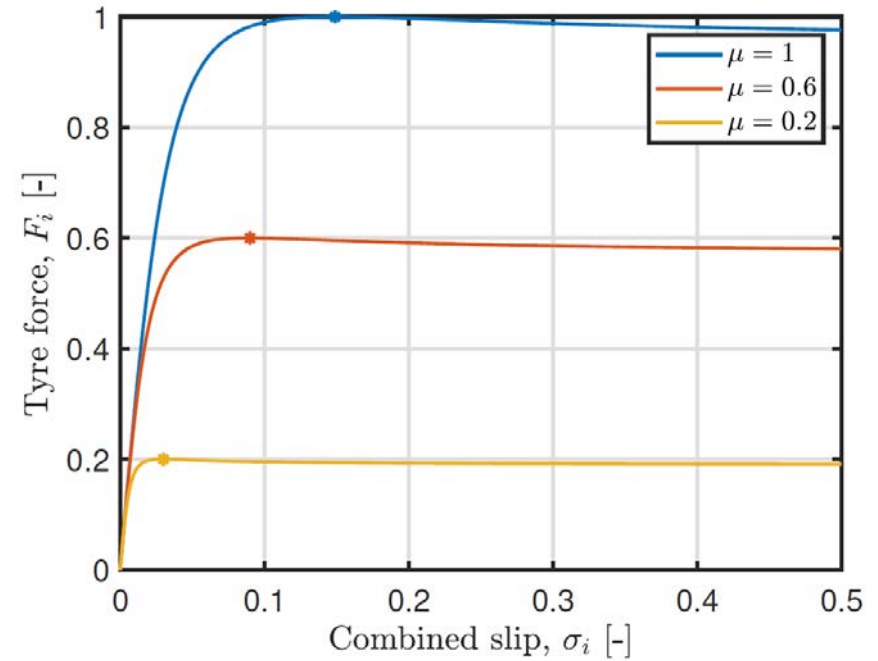

Road friction information

- Tyre as a sensor
- Camera

Road class: e.g. snow → Friction range

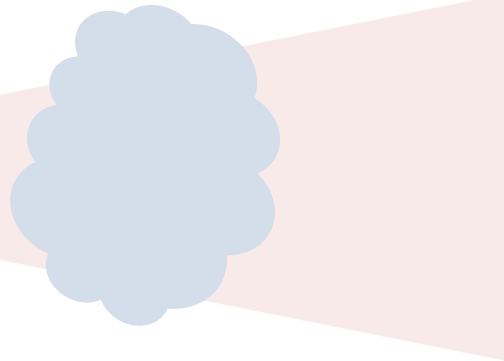

Road friction information

- Tyre as a sensor
- Camera
- Cloud Data

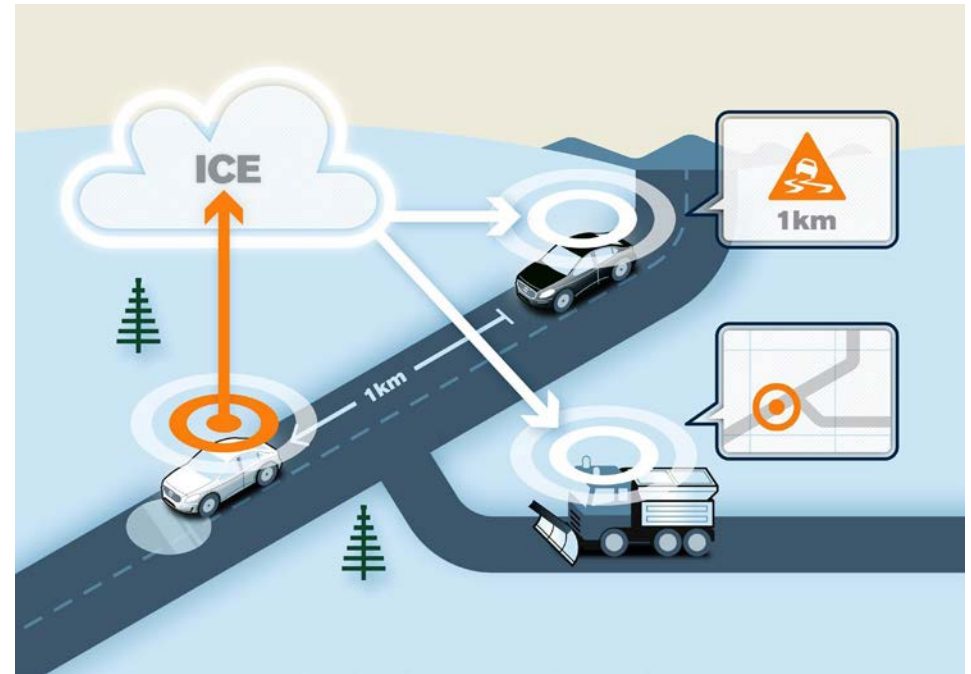



V O L V O



The moose and the braking distance



The moose and the braking distance

- Predict the shortest braking distance S ?
- S depends on friction
- Pose assumptions on the road condition ahead
- Implications on path-planning & control



The moose and the braking distance: Uniform Road

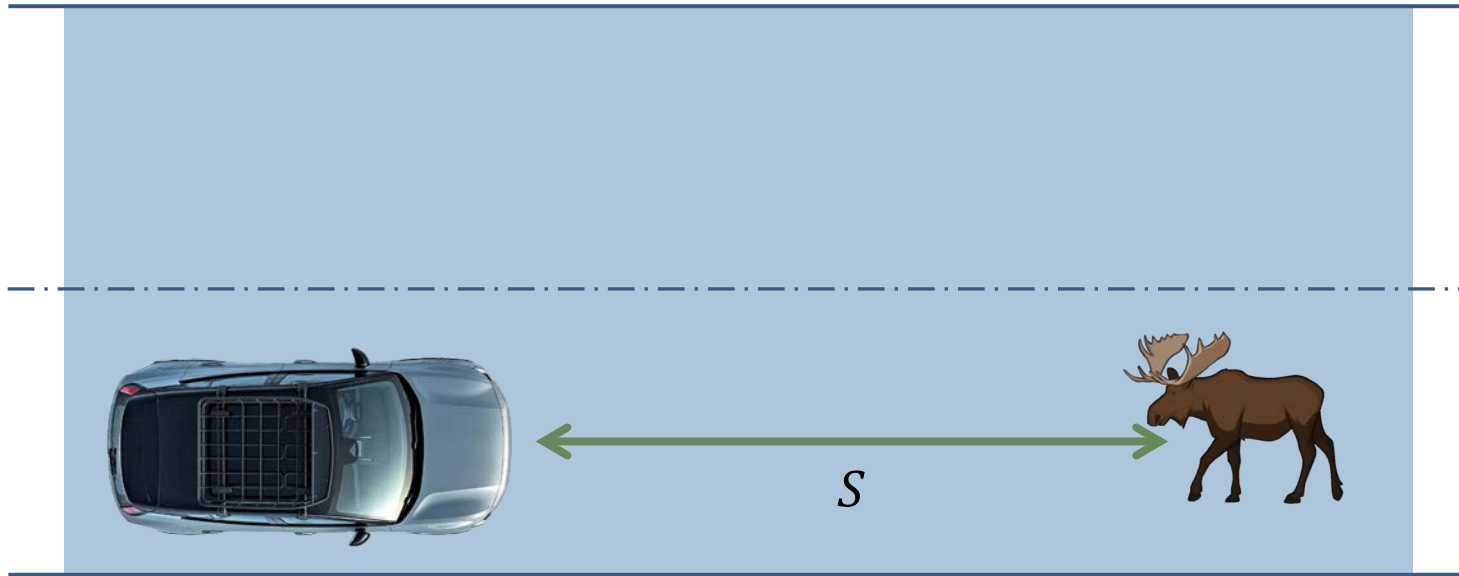

Uniform Road: Braking distance equation

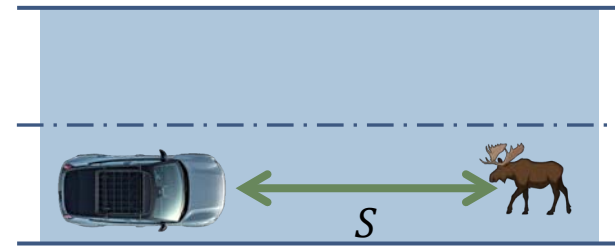

Braking distance:
$$S = \frac{1}{2} \frac{V^2}{\bar{\mu}g}$$

where

- $\bar{\mu}$ is the average road friction coefficient along the path with $\mu \in [0 \ 1]$,
- V the vehicle's speed,
- g is the gravity constant

Uniform Road: Friction deviation \rightarrow braking distance deviation

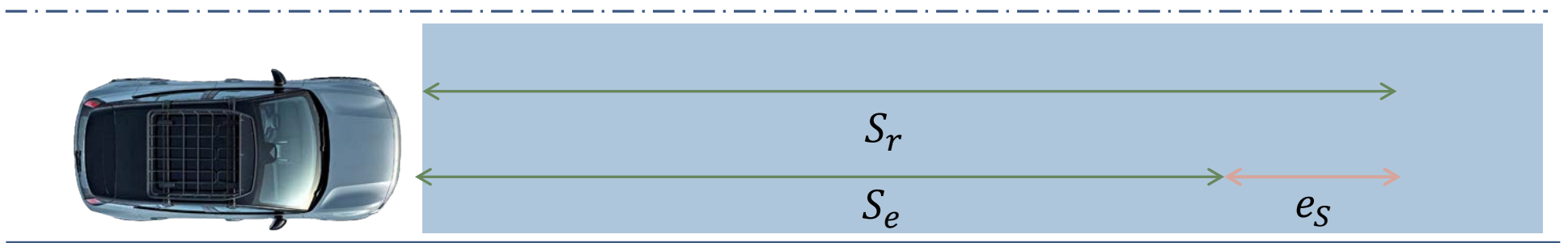
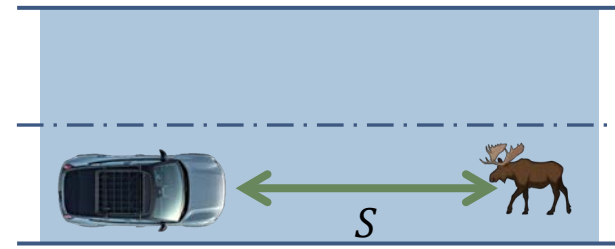

Uniform Road: Friction and distance deviations

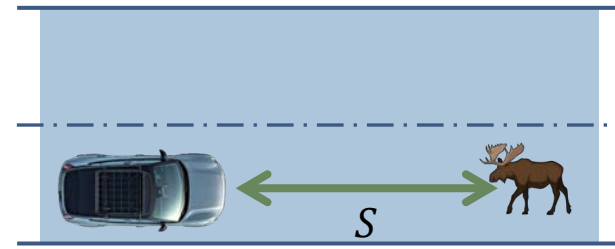

- Deviation: estimated – real

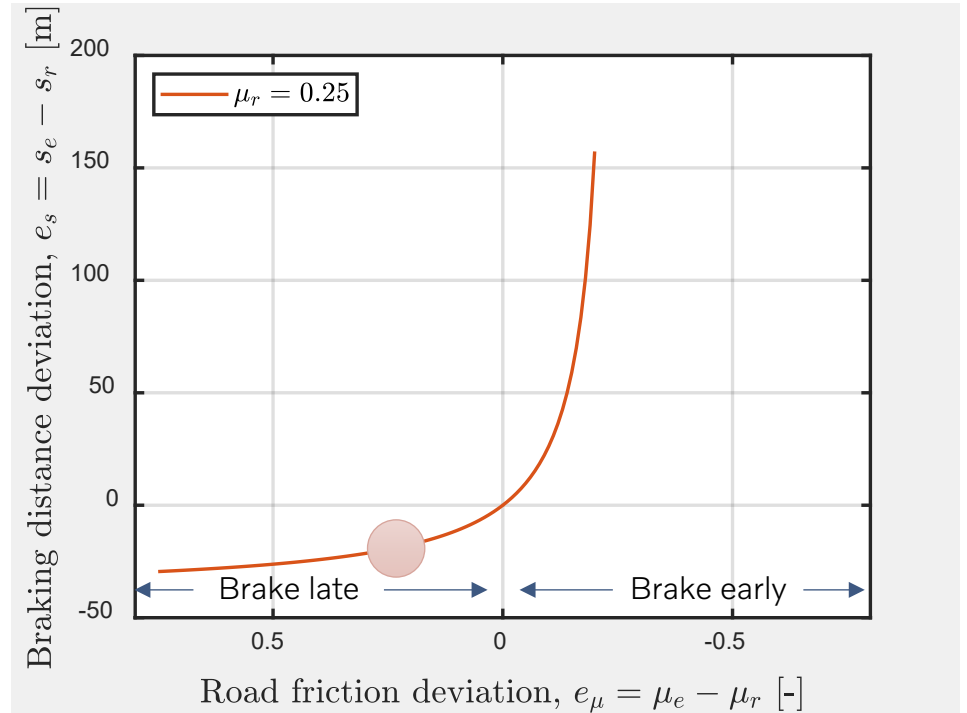

Uniform Road: Friction and distance deviations

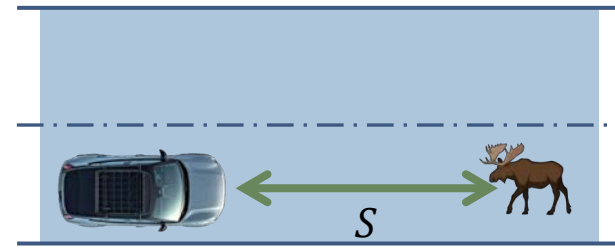

- Deviation: estimated – real
- Same friction deviation:
Lower friction \rightarrow larger br. distance deviation
- Cost of misestimating friction significant at lower frictions

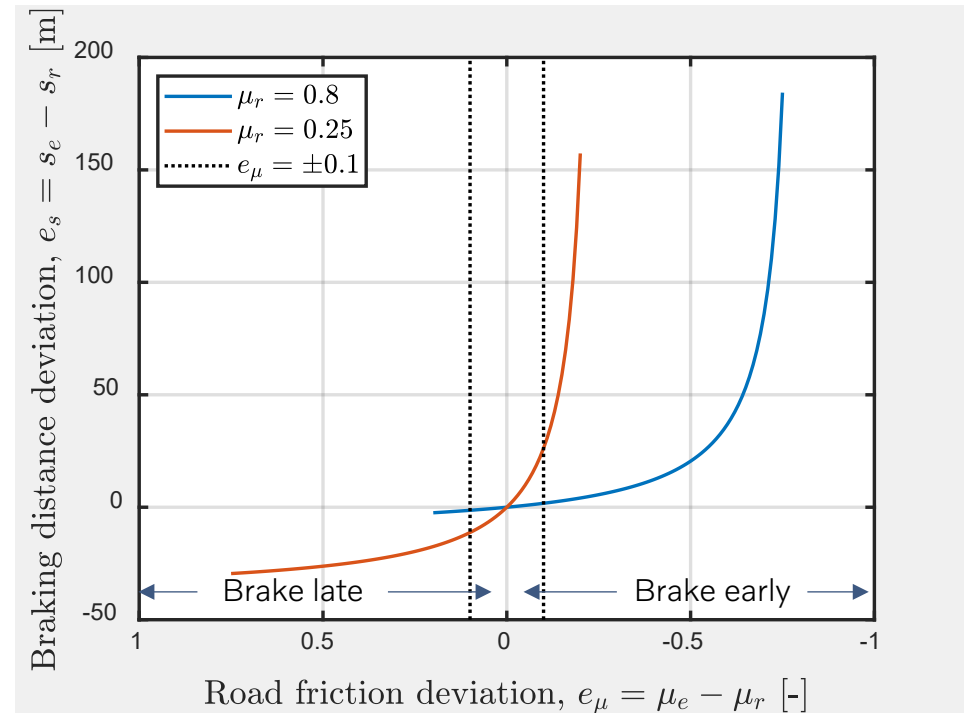

The moose and the braking distance: Split Friction Road

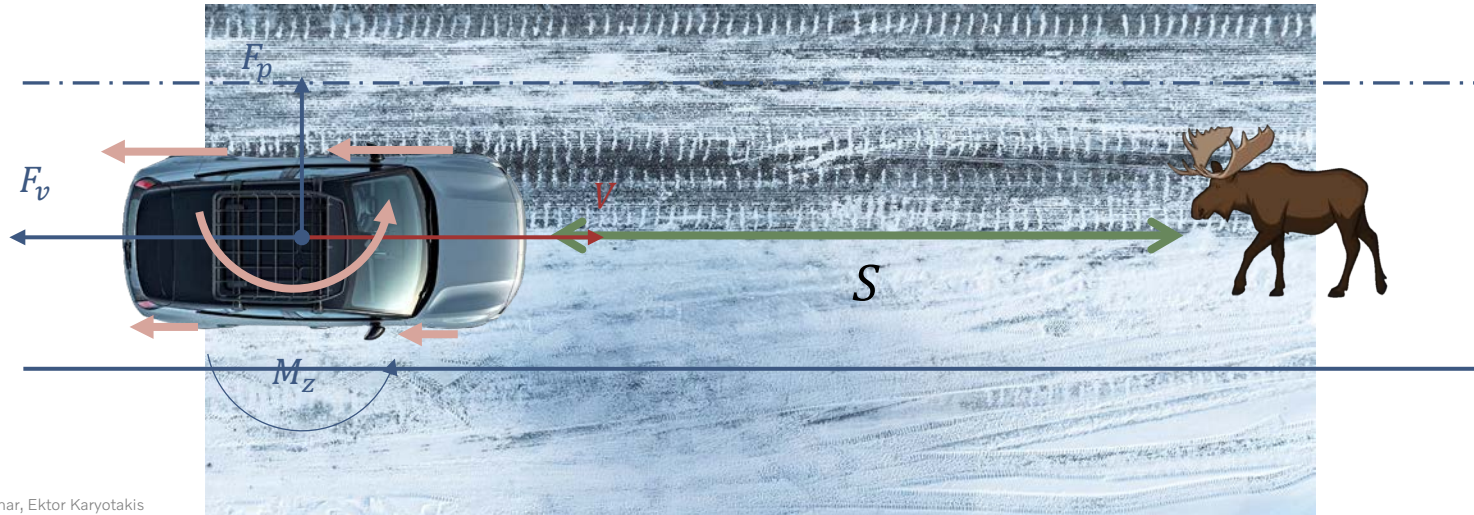

Split Friction Road: Velocity and global forces

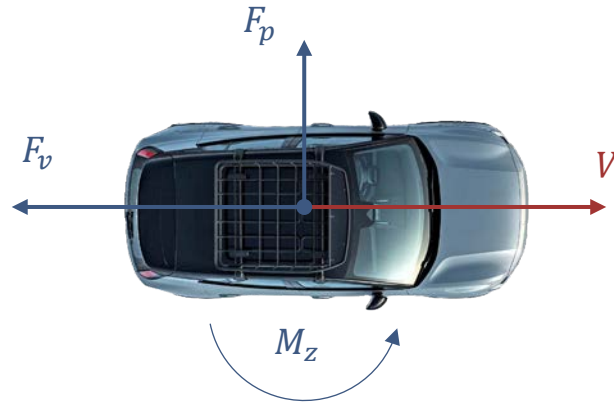
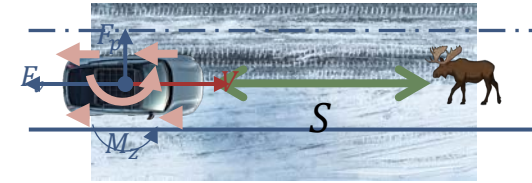

Split Friction Road: Straight road

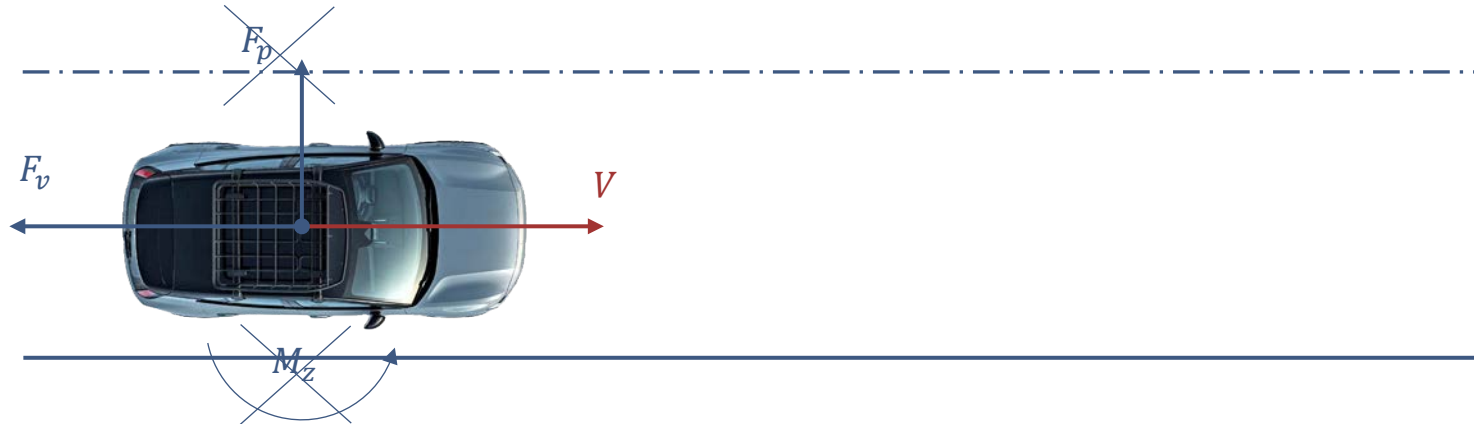
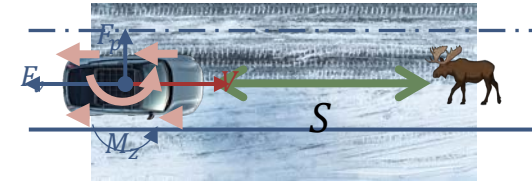

Split Friction Road: Maximum braking gives shortest distance on a straight road

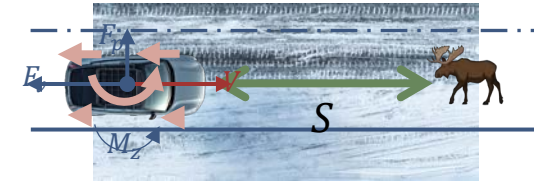

$\max F_v$

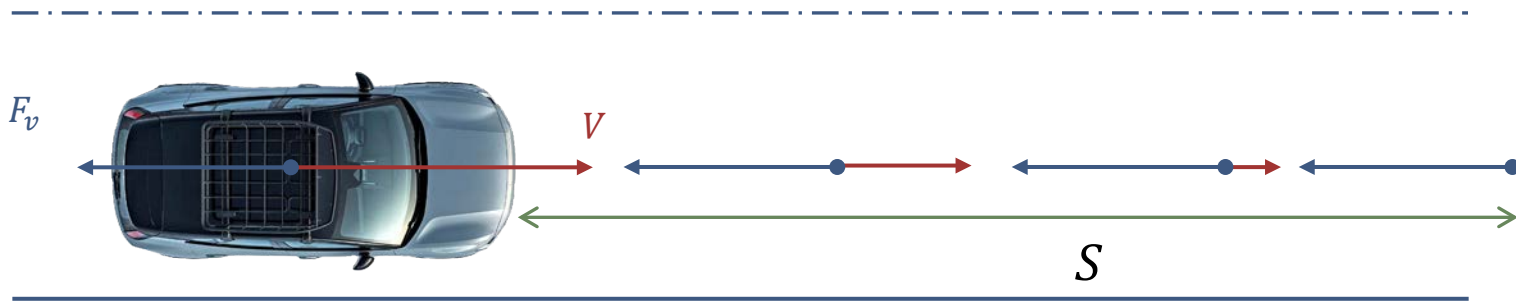

Split Friction Road: Maximum braking on straight roads

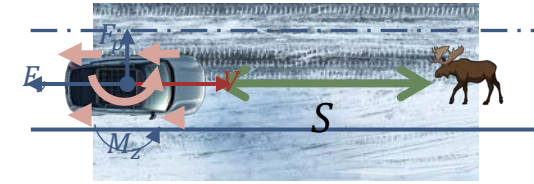

Instantaneous optimal problem

$$\begin{aligned} \max \quad & F_v \\ \text{subject to} \quad & F_p = 0 \\ & M_z = 0 \end{aligned}$$

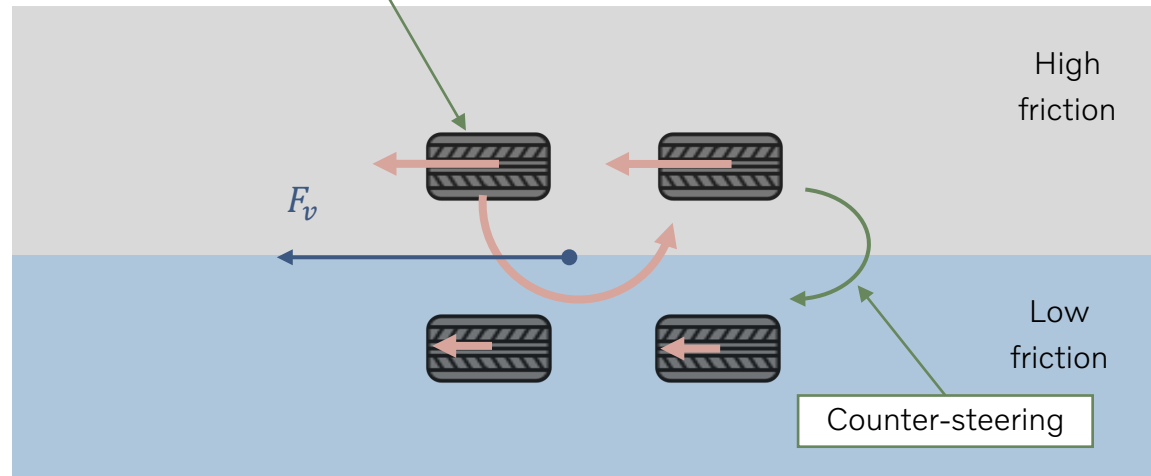
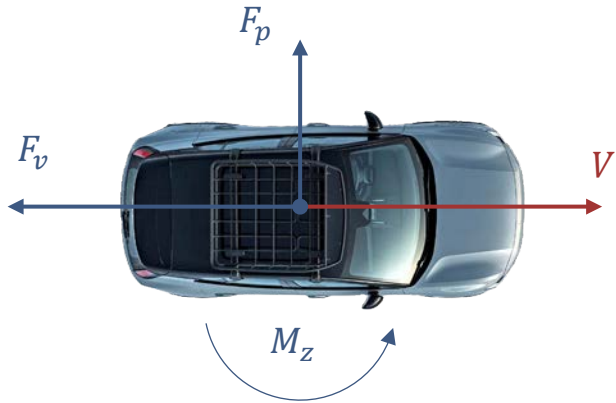

Split Friction Road: Max braking per friction asymmetry

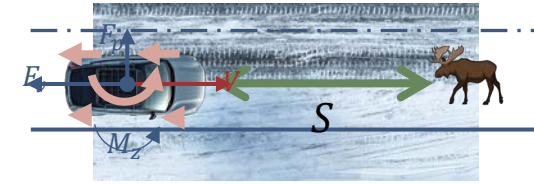

- Counter-steering necessary for max braking

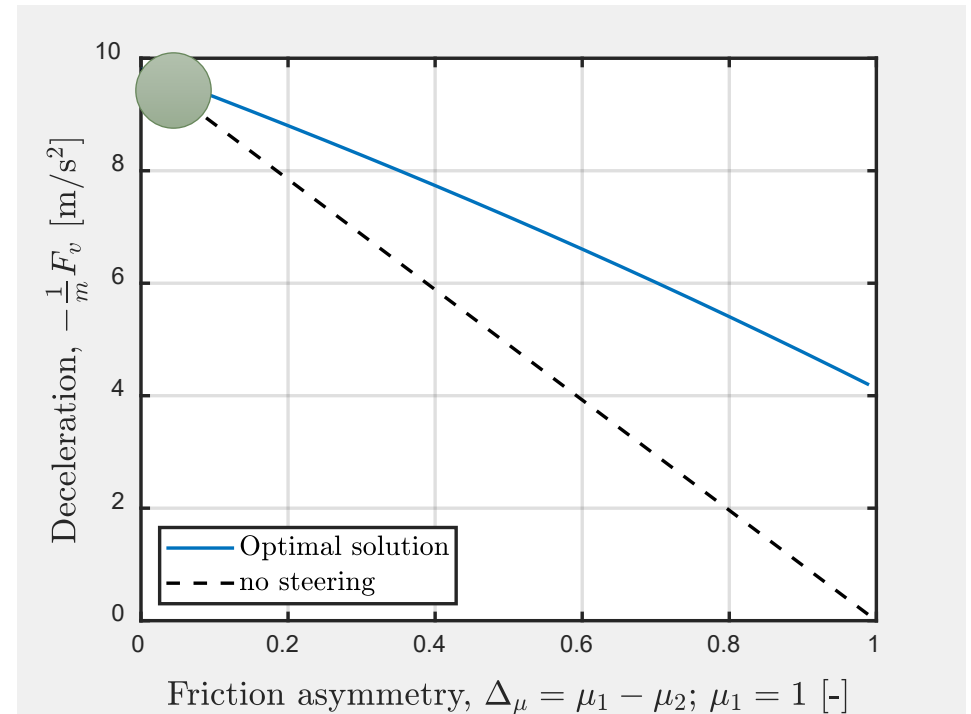

Split Friction Road: Tyre curves at zero split friction

- Maximum force at friction peak ‘*’
- Optimal point ‘x’

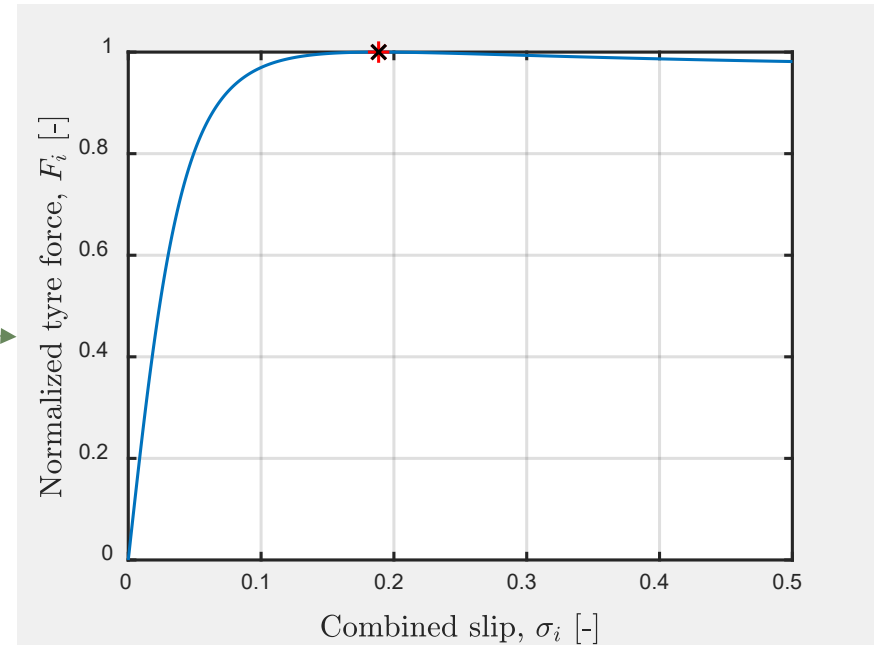
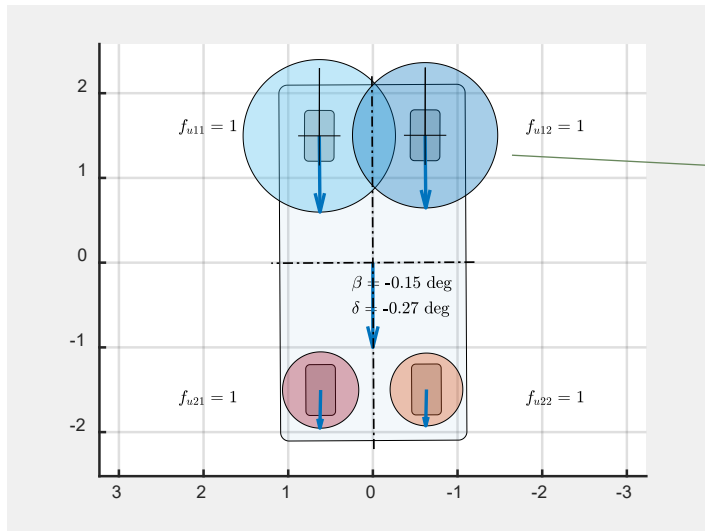
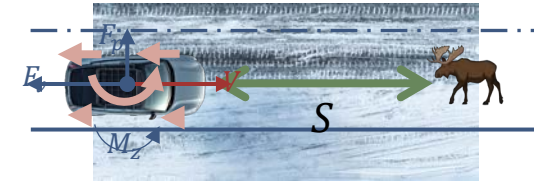
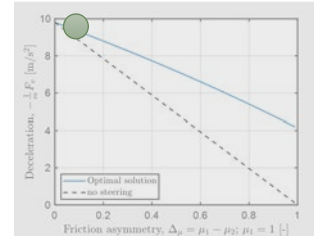

Split Friction Road: Tyre curve at extreme split friction

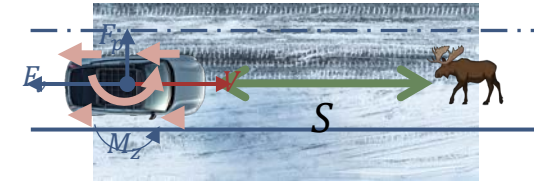
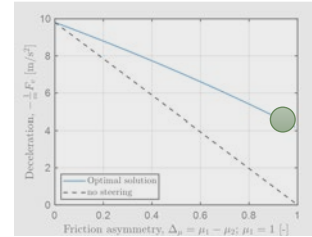

- Optimal point 'x' moves away from peak '*'
- Conclusion: At extreme split friction low-friction tyres at unstable tyre region

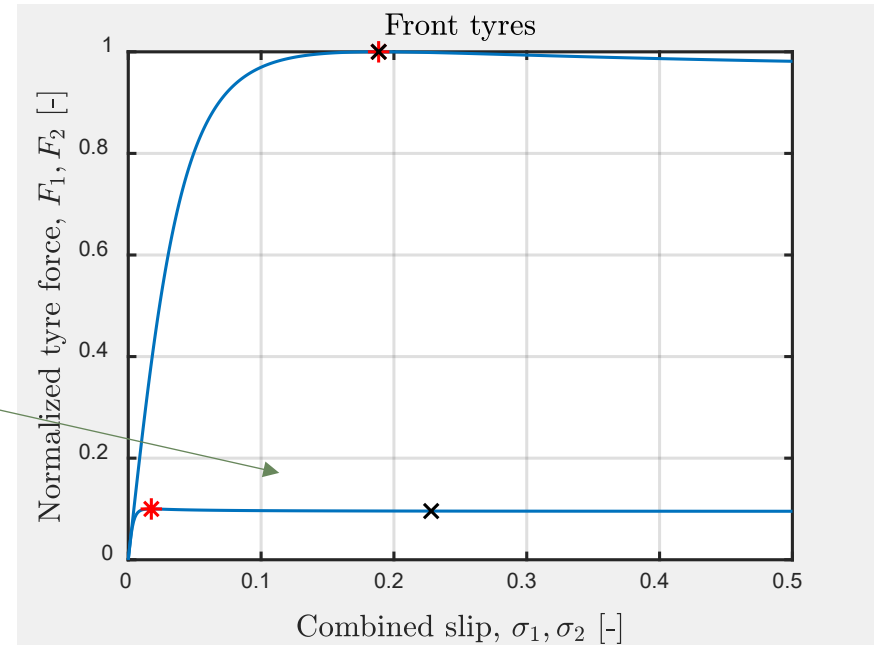
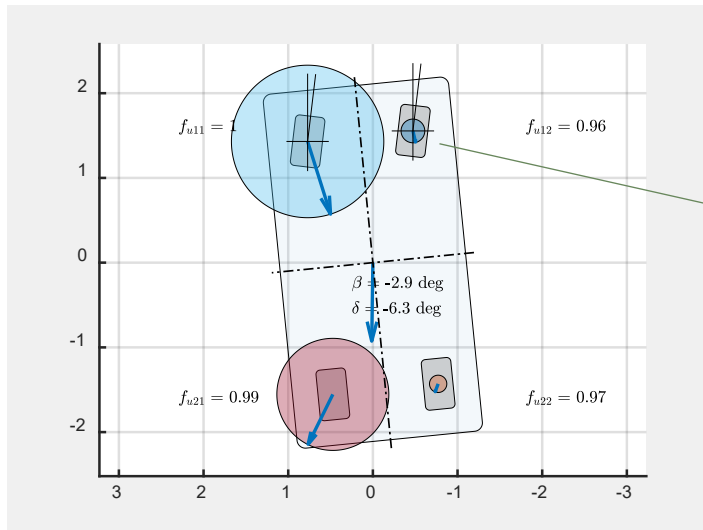

The moose and the braking distance: Optimal Path

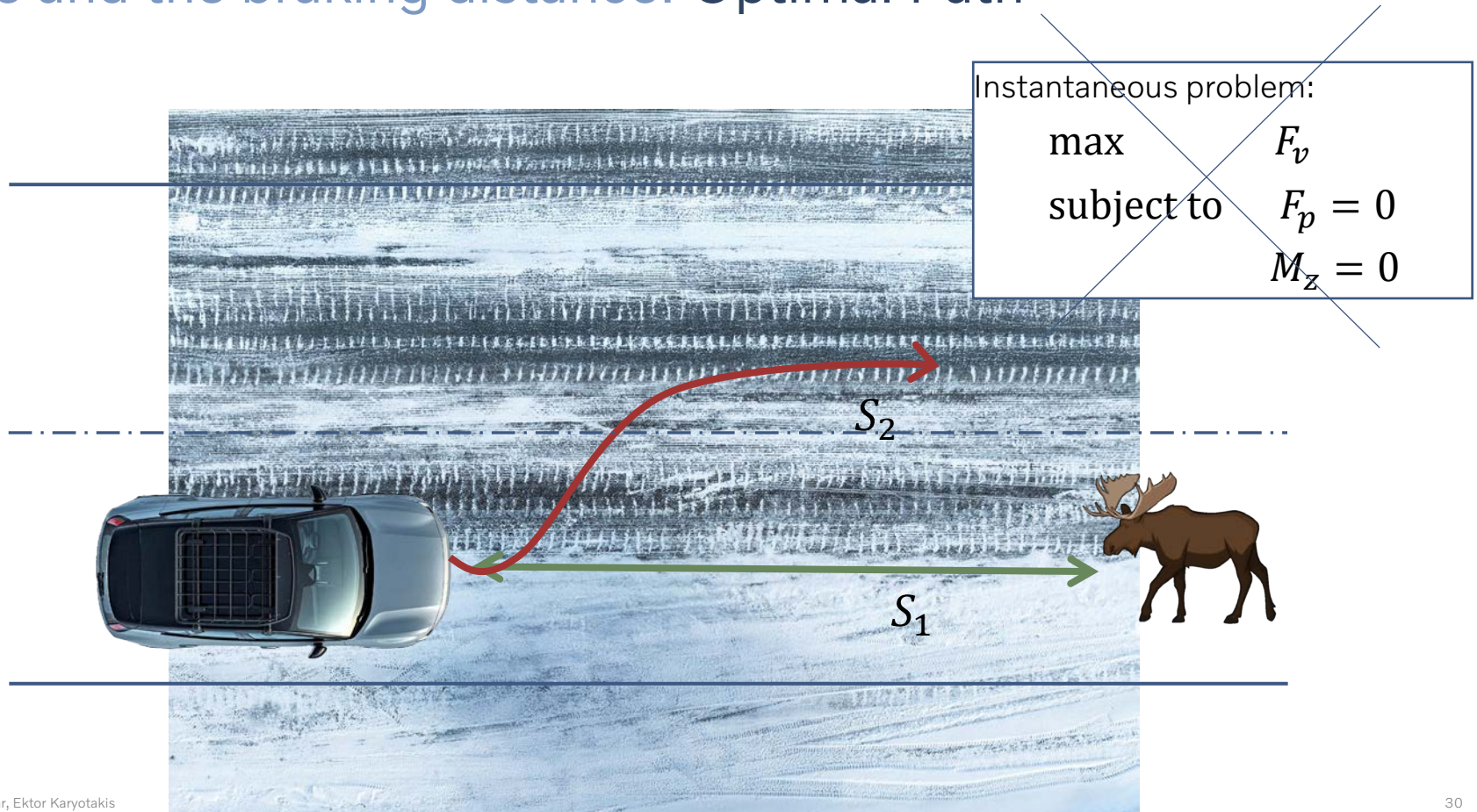

Optimal Path: Road friction profile from winter roads: Snow-tracks

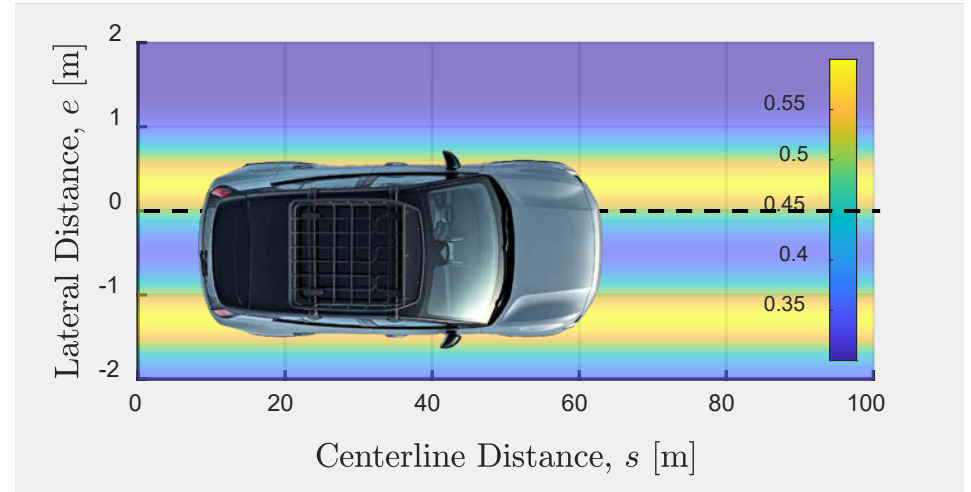
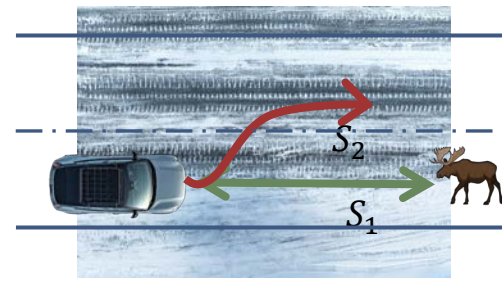

Optimal Path: Simulation & verification

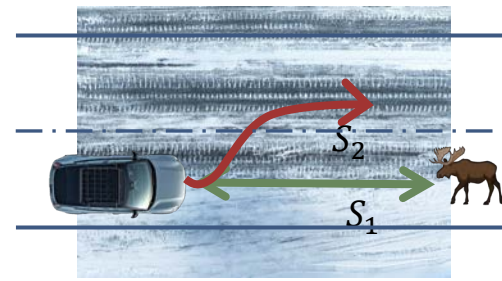

1. Full trajectory optimization with two vehicle models:

- Particle Model (PM)
- Single-track (ST)

2. Simulation in high-fidelity environment CarMaker™

- Advanced tyre model
- Verified chassis

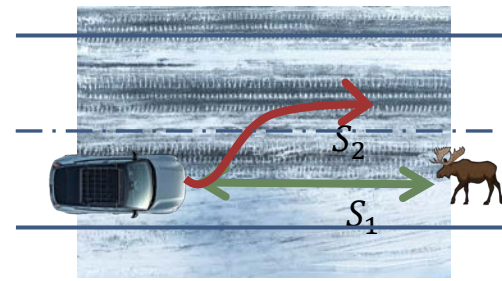

Optimal Path: CarMaker simulation structure

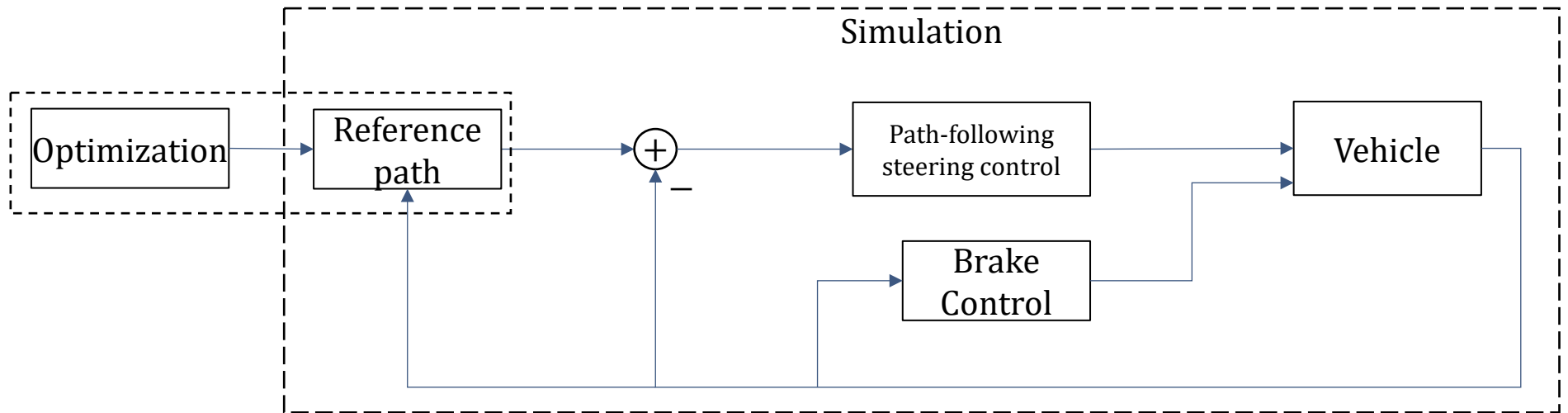

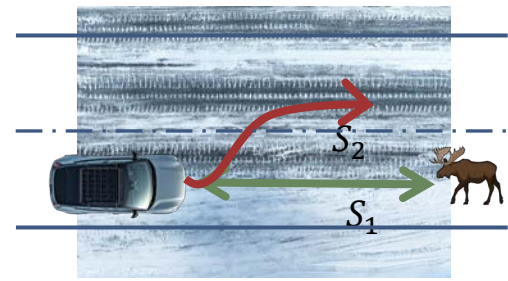

Optimal Path: Similar paths for all models

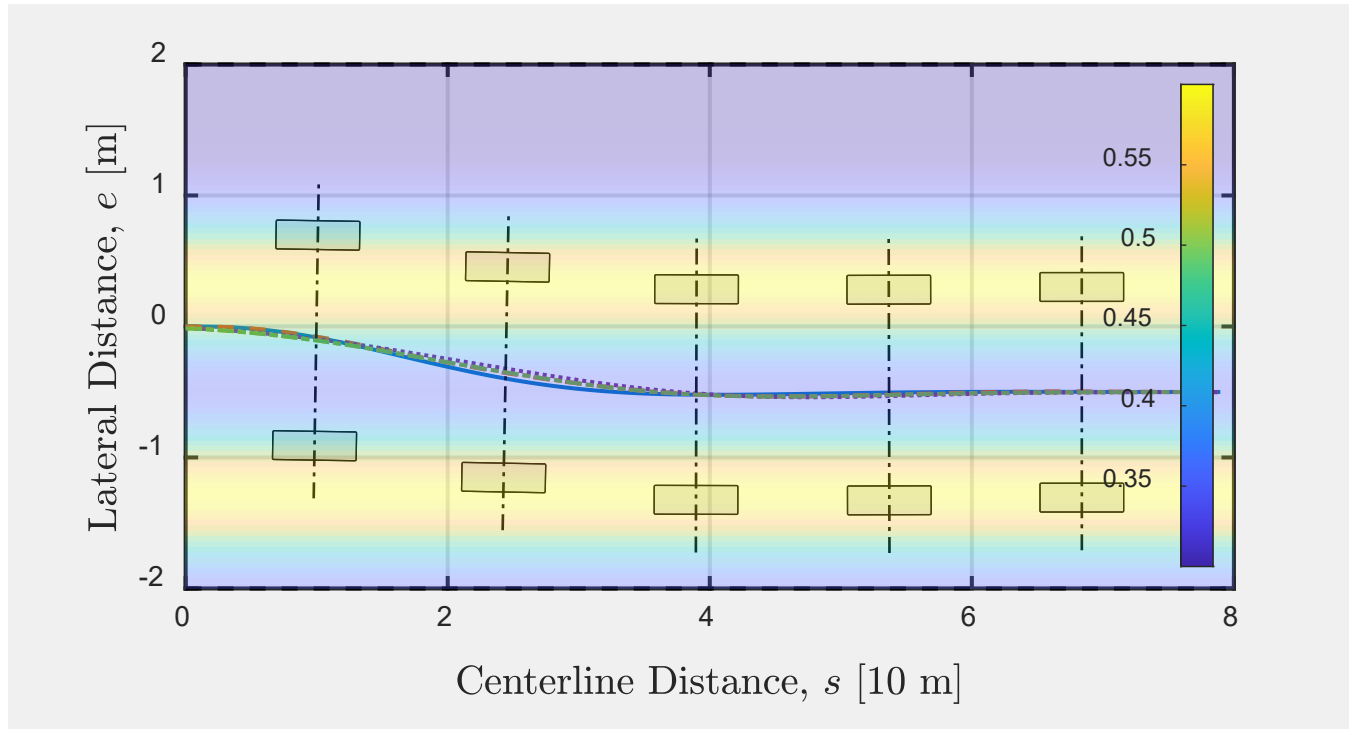

Optimal Path: Braking distance on snow-tracks

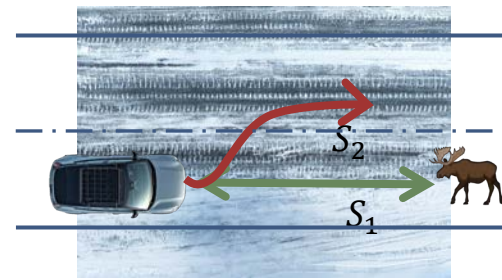

- PM model minor differences to more advanced model
- Moving to high friction can significantly reduce braking distance

		Braking distance	
Simulation	w/ PM path	78.4m	
	w/ ST path	78.8m	
	No steering	108.2m	+37%

Summary

1. Braking on uniform friction roads
 - Friction estimate deviations critical at low frictions
2. Braking on split friction
 - Extreme split friction optimal solution + control
3. Optimal path
 - Significant gains moving towards higher friction
 - Particle model sufficient for friction-aware path planning

Future work

- Adaptive speed and path framework based on predicted friction
- Addressing friction uncertainty

V O L V O

Thank you!

Presentation 7a:
KTH, Vehicle engineering Master programme
Mikael Nybacka, KTH



Master programme in Vehicle Engineering

Mikael Nybacka

Associate Professor in Vehicle Dynamics

Programme Director for Vehicle Engineering

Future of Vehicle Engineering – Exciting and needed transformation going on – requiring engineers!

Autonomous

- Flexible
- Environmental friendly
- Safe
- Cheap
- Personal
- Comfortable
- Secure
- Fast
- Integrated
- Just
- ...

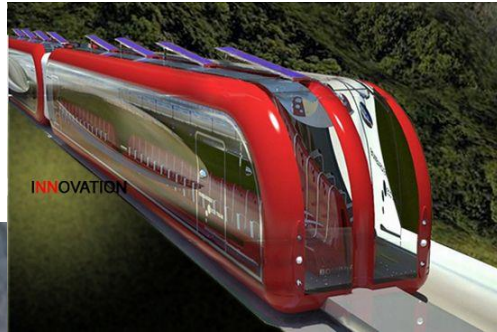

Master programme in Vehicle Engineering

- Some quick facts

Two-year programme (120 ECTS credits) given in English

Two tracks, **road** and **rail** vehicles

600-700 applicants and ~**300** 1st hand applicants over the last 5 years

Admitted 45 students 2024 (~**15%** acceptance rate from 1st hand applicants of int. master intake)

Total amount of student / year = **45-55**

Around **1/3 Swedish** and **2/3 international** students

13 Nationalities 2024

~5 female students / year (we want more to apply!)



Students starting autumn 2024

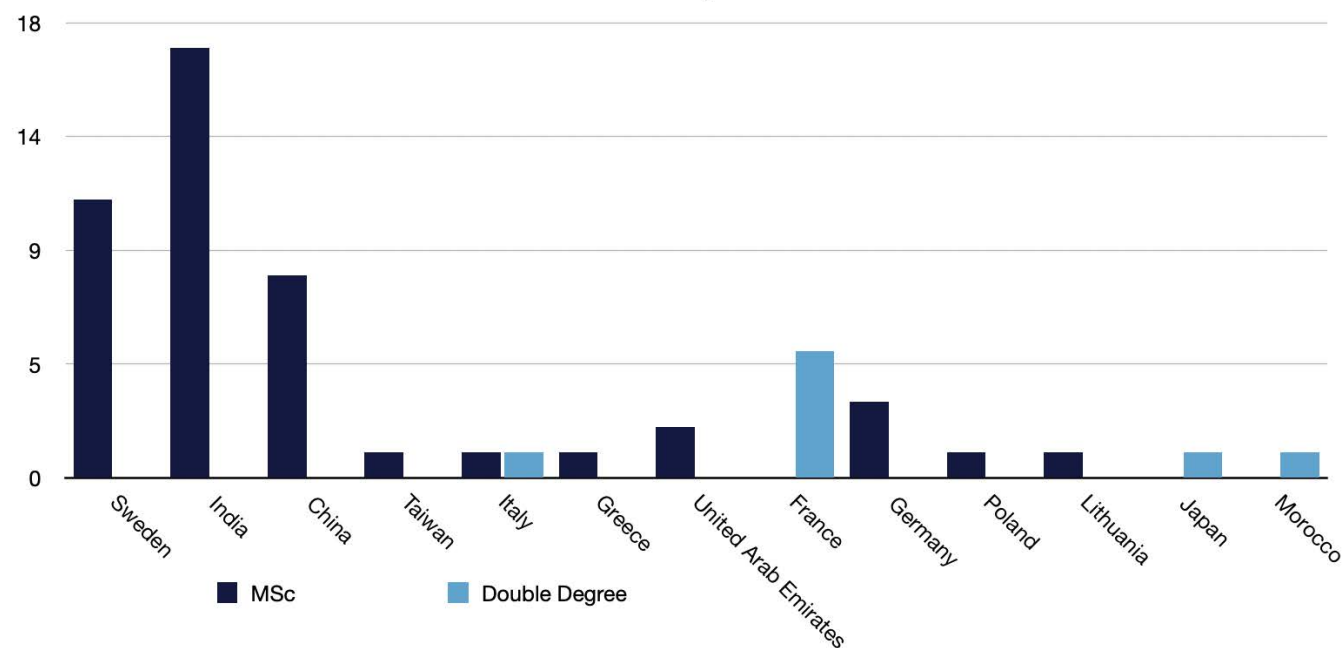



Entry requirements

- A bachelor's degree or comparable qualification equivalent to a Swedish bachelor's degree from an internationally recognised university. 180 ECTS
- English proficiency, IELTS Academic or IELTS UKVI: An overall score of 6.5, with no selection lower than 5.5
 - Or other like TOEFL, ECPE, PTE, ESOL
- Specific documents for Vehicle Engineering
 - Summary Sheet (**IMPORTANT**)
- Selection criteria
 - Study results (grades, relevant subjects and English) motivation for studies (motivation letter) and prior education.
 - Prior education is evaluated based on the quality and suitability of the subjects that are relevant for the programme applied to. The merit rating is carried out on a scale of 1-75.
- Specific requirements:
- Mathematics and Programming, equivalent to approximately 25 ECTS credits in total, which must include courses or course modules in
 - 1. control theory
 - 2. programming
- Applied mechanics, equivalent to approximately 20 ECTS credits in total, which must include courses or course modules in
 - 3. solid mechanics
 - 4. fluid mechanics

Programme structure

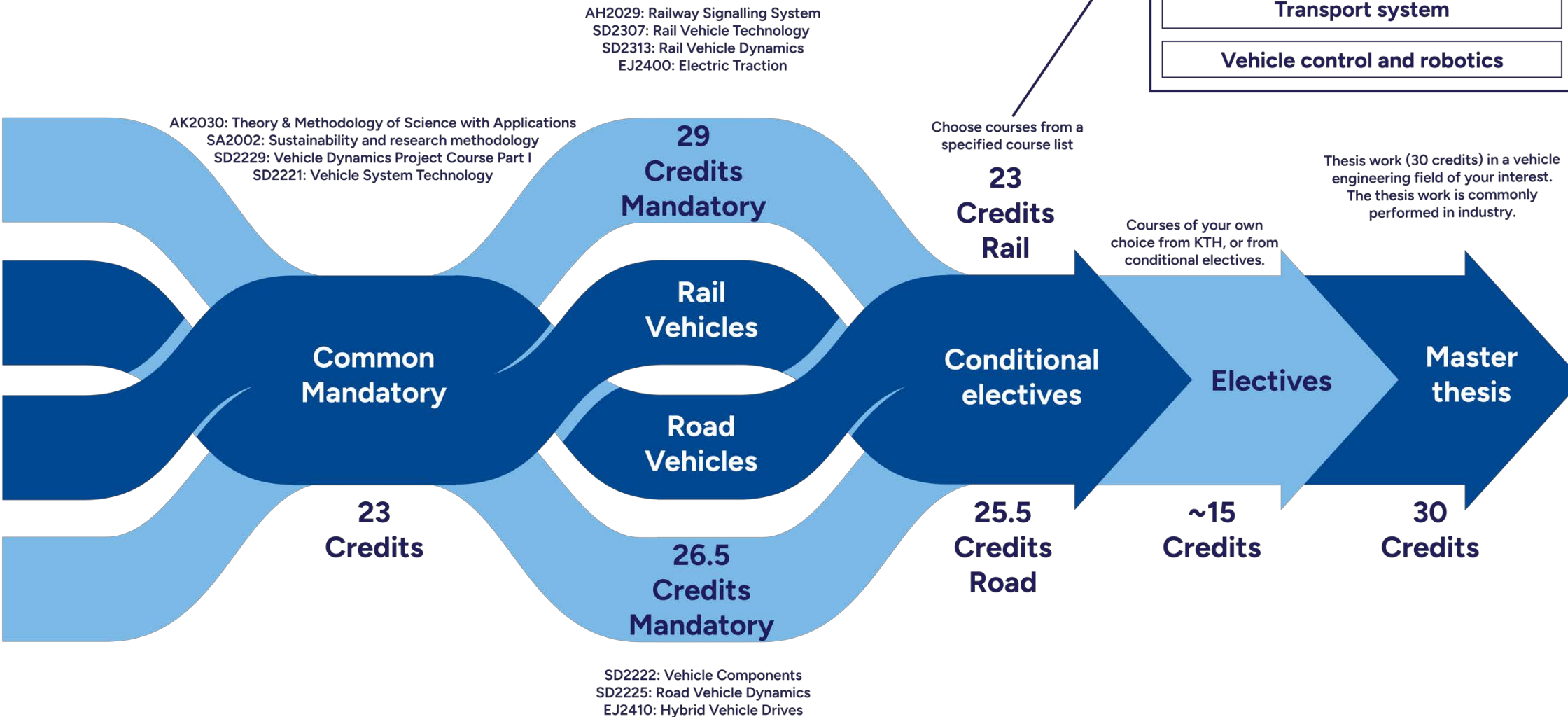



Conditional elective courses in these topic areas, choose any course from any topic area

Vehicle control and robotics MF2030: Mechatronics basic course MF2043: Robust mechatronics MF2007: Dynamics and Motion Control EL2520: Control Theory and Practice, Adv. SD2231: Applied Vehicle Dynamics Control EL2700: Model Predictive Control SD2230: Vehicle Dynamics Project course (Part 2)	Vehicle structures and design SD2411: Lightweight Structures and FEM SD2150: Experimental Structure Dynamics SD2416: Structural Optimisation and Sandwich Design SD2190: Vehicle Acoustics and Vibration SD2111: Engineering acoustics SD2250: Sustainable vehicle design SD2230: Vehicle Dynamics Project course (Part 2)	Vehicle aerodynamics and acoustics SD2155: Flow Acoustics SG2211: Vehicle Aerodynamics SD2625: Comp. Vehicle Aerodynamics SG1217: Fluid mechanics, basic course SG1220: Fluid mechanics for engineers SG2214: Fluid Mechanics SD2250: Sustainable vehicle design SD2230: Vehicle Dynamics Project course (Part 2)	Transport system AH2307: Urban modelling and decision AH2171: Traffic Engineering Management AH2170: Transport Data Collection and Analysis AH2174: Traffic Simulation Modelling and Application AH2173: Public transport
AH2029: Railway Signalling System SD2307: Rail Vehicle Technology SD2313: Rail Vehicle Dynamics EJ2400: Electric Traction			Electric mobility MF2030: Mechatronics basic course SD2250: Sustainable vehicle design CK2300: Batteries CK2320: Hydrogen SD2230: Vehicle Dynamics Project course (Part 2) MJ2506: Energy Technologies for Sustainable Transportation

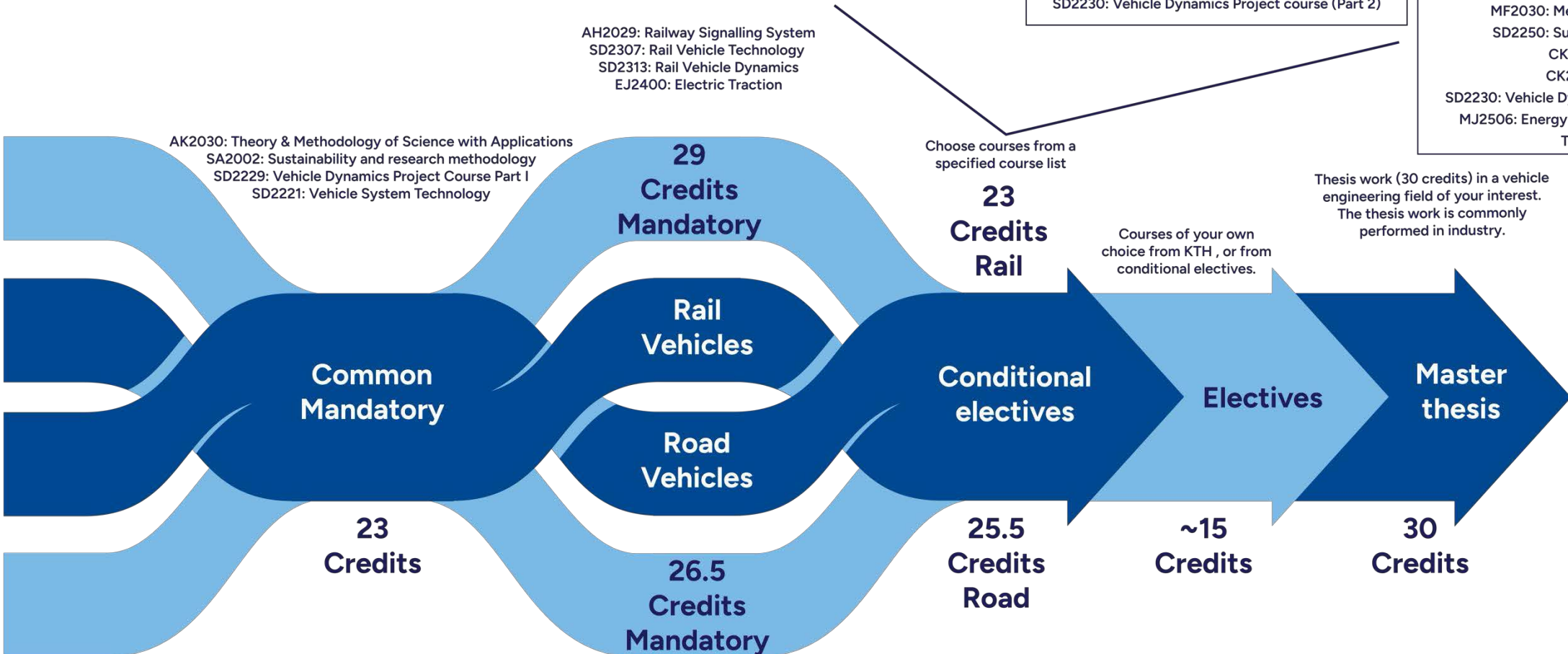

Programme structure

Mandatory courses

	Year 1				Year 2			
	1:1	1:2	1:3	1:4	2:1	2:2	2:3	2:4
ROAD	AK2030 Theory & science 4.5 hp	EJ2410 Hybrid vehicle drives 7.5 hp				SA2002 Sustainable dev. & research methods 3.0 hp	SD221X Master thesis 30 hp	
	SD2221 Vehicle system technology 8 hp	SD2222 Vehicle components 8 hp	SD2225 Road vehicle dynamics 11 hp		SD2229 Vehicle dynamic project Part I 7.5 hp			

	1:1	1:2	1:3	1:4	2:1	2:2	2:3	2:4
RAIL	AK2030 Theory & science 4.5 hp				AH2029 Railway signalling systems 7.5 hp	SA2002 Sustainable dev. & research methods 3.0 hp	SD231X Master thesis 30 hp	
	SD2221 Vehicle system technology 8 hp	SD2307 Rail vehicle technology 7.5 hp	SD2313 Rail vehicle dynamics 8 hp	EJ2400 Electric traction 6 hp	SD2229 Vehicle dynamic project Part I 7.5 hp			

	mandatory
	mandatory, but can be read during 1 st or 2 nd year
	mandatory, can be read in any study period

Road - Control focus

1:1	1:2	1:3	1:4	2:1	2:2	2:3	2:4
MF2030 Mechatronics Basic course 6hp	EJ2410 Hybrid Vehicle drives 7.5hp	EL2450 Hybrid and Embedded Control Systems 7.5hp	SD2231 Applied Vehicle Dynamics Control 7.5 hp	EL2700 Model Predictive Control 7.5 hp	MF2007 Dynamics and motion Control 7.5 hp	SD221X Master thesis 30 hp	
AK2030 Theory & science 4.5hp	SA2002 Sustainable dev. research methods 3hp						
SD2221 Vehicle system technology 8 hp	SD2222 Vehicle components 8 hp	SD2225 Road vehicle dynamics 11 hp	SD2229 Vehicle dynamic project Part I 7.5 hp	SD2230 Vehicle dynamic project Part 2 7.5 hp			

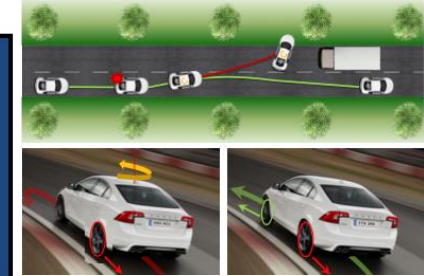

	Conditionally electives
	Free course

Road - Electric powertrain focus

1:1	1:2	1:3	1:4	2:1	2:2	2:3	2:4
MF2030 Mechatronics Basic course 6 hp	EJ2410 Hybrid Vehicle drives 7.5hp	CK2320 Hydrogen 7.5 hp	EJ2400 Electric traction 6 hp	SD2250 Sustainable vehicle design 7.5 hp	SD2230 Vehicle dynamic project Part 2 7.5 hp	SD221X Master thesis 30 hp	
AK2030 Theory & science 4.5hp	SA2002 Sustainable dev. research methods 3hp						
SD2221 Vehicle system technology 8 hp	SD2222 Vehicle components 8 hp	SD2225 Road vehicle dynamics 11 hp	SD2229 Vehicle dynamic project Part I 7.5 hp	CK2300 Batteries 7.5 hp			



Road - Design focus

1:1	1:2	1:3	1:4	2:1	2:2	2:3	2:4
SD2111 Engineering Acoustics 6 hp	EJ2410 Hybrid Vehicle drives 7.5hp	SD2125 Experimental structure dynamics 9 hp		SD2250 Sustainable vehicle design 7.5 hp	SD2416 Structural Optimisation and Sandwich Design 6 hp	SD221X Master thesis 30 hp	
AK2030 Theory & science 4.5hp	SA2002 Sustainable dev. research methods 3hp						
SD2221 Vehicle system technology 8 hp	SD2222 Vehicle components 8 hp	SD2225 Road vehicle dynamics 11 hp	SD2229 Vehicle dynamic project Part I 7.5 hp	SD2230 Vehicle dynamic project Part 2 7.5 hp			



Rail - Control focus

1:1 1:2 1:3 1:4 2:1 2:2 2:3 2:4

MF2030 Mechatronics Basic course 6hp	SA2002 Sustainable dev. & research methods 3 hp	SD2313 Rail vehicle dynamics 8 hp	EJ2400 Electric traction 6 hp	EL2700 Model Pred. Control 7.5 hp	MF2007 Dynamics and motion Control 7.5 hp	SD231X Master thesis 30 hp
AK2030 Theory & science 4.5hp				AH2029 Railway signalling sys. 7.5 hp		
SD2221 Vehicle system technology 8 hp	SD2307 Rail vehicle technology 7.5 hp	EL2450 Hybrid and Embedded Control Systems 7.5hp	SD2231 Applied Vehicle Dynamics Control 7.5 hp	SD2229 Vehicle dynamic project Part I 7.5 hp	SD2230 Vehicle dynamic project Part 2 7.5 hp	

	Conditionally electives
	Free course

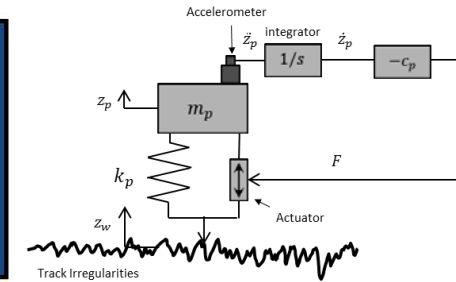

Rail - Traffic focus

1:1 1:2 1:3 1:4 2:1 2:2 2:3 2:4

AH2170 Transport Data Collection and an. 7.5 hp	AF2901 Road and Rail. Track Engine. 7.5 hp	SD2313 Rail vehicle dynamics 8 hp	EJ2400 Electric traction 6 hp	AH2029 Railway signalling system 7.5 hp	AH2028 Railway traffic market and planning advanced course 7.5 hp	SD231X Master thesis 30 hp
AK2030 Theory & science 4.5hp	SA2002 Sustainable dev. research methods 3hp					
SD2221 Vehicle system technology 8 hp	SD2307 Rail vehicle technology 7.5 hp	AH2301 Transport Policy and Evaluation 7.5 hp	AH2173 Public Transport 7.5 hp	SD2229 Vehicle dynamics project Part I 7.5 hp	AH2171 Traffic Engineering Managem. 7.5 hp	



Rail - Dynamics focus

1:1 1:2 1:3 1:4 2:1 2:2 2:3 2:4

AK2030 Theory & science 4.5 hp	SA2002 Sustainable dev. & research methods 3 hp	SD2313 Rail vehicle dynamics 8 hp	EJ2400 Electric traction 6 hp	AH2029 Railway signalling system 7.5 hp	MF2007 Dynamics and motion Control 7.5 hp	SD231X Master thesis 30 hp
SD2221 Vehicle system technology 8 hp	SD2307 Rail vehicle technology 7.5 hp	SD2125 Experimental structure dynamics 9 hp		SD2229 Vehicle dynamics project Part I 7.5 hp	SD2230 Vehicle dynamics project Part 2 7.5 hp	

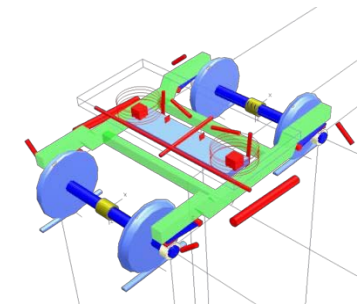

Experimental vehicles, equipment and test tracks



Volvo S90 D5 AWD Geartronic



Roller rig



RCV-Dynamic

Research
Concept Vehicles

RCV-E



Driving simulators

Arlanda test track
Drive Lab 1 and 2



Lunda flygfält



Vehicle Engineering Lab

- Education
- Experiments
- Computer exercises
- Studies on your own

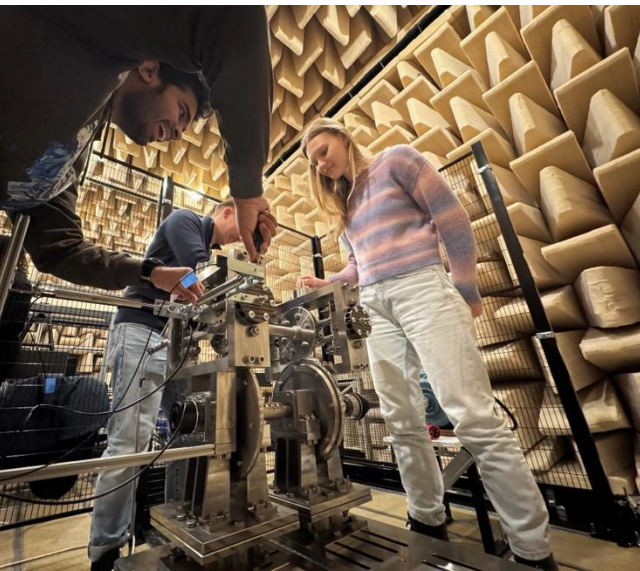



Project course final year

Companies send project ideas to mnybacka@kth.se in June the latest

Delsbo – Making it happen
 VDPCP1 - Final presentation

By: Silvia Milani, Philipp Linzbichler
 Supervisors: Zhendong Liu, Bastian Schick

Date: 14/10/2022

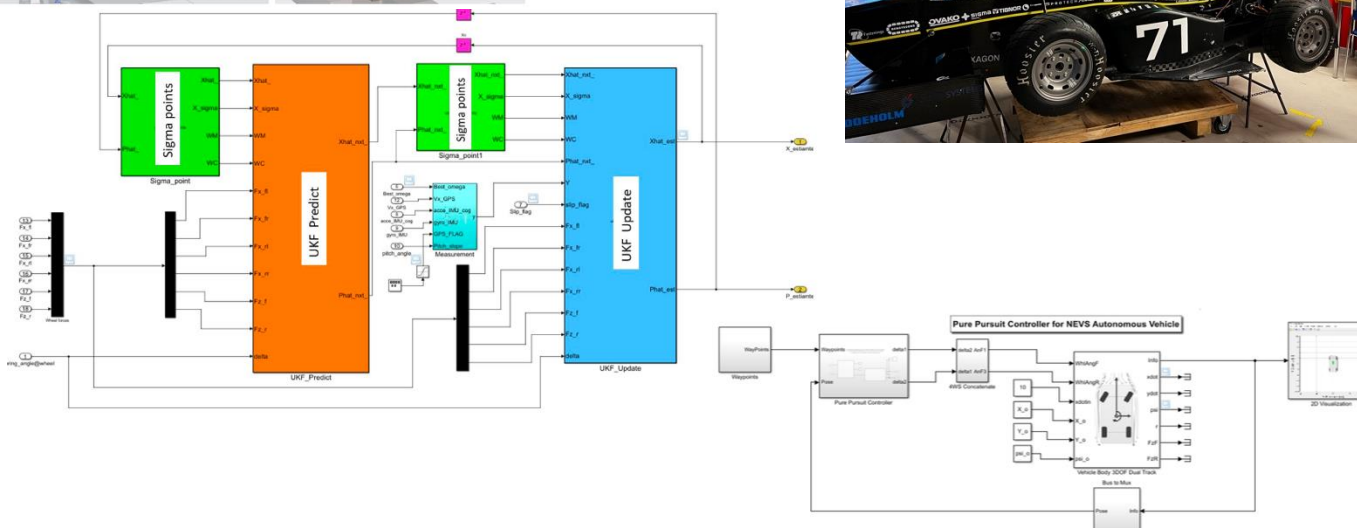
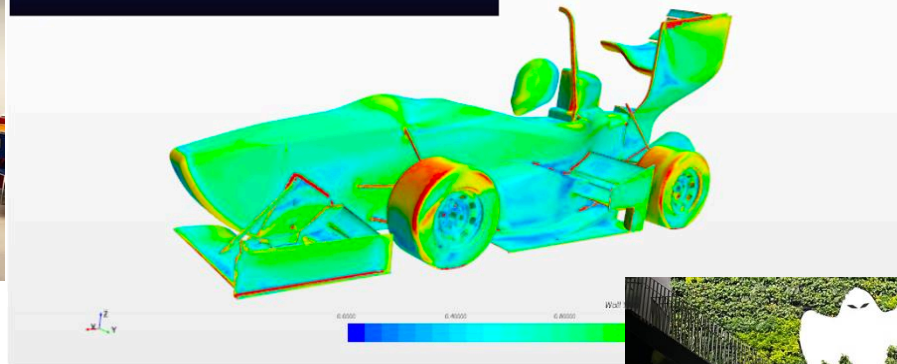
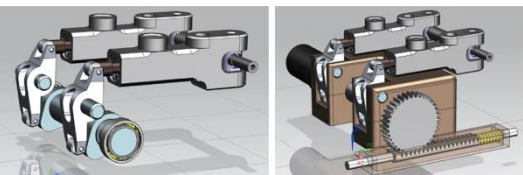
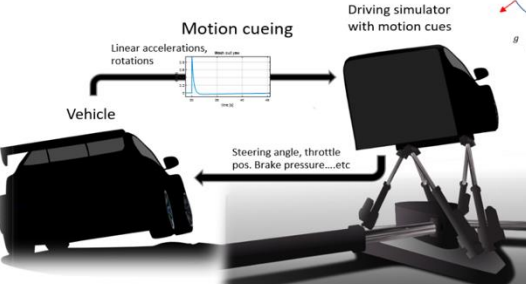
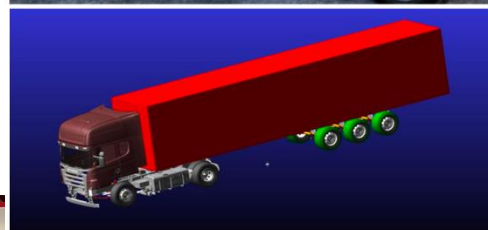

Questions?



Mikael Nybacka
Programme director

mnybacka@kth.se

Research groups ***Rail vehicles, Vehicle dynamics, Aero dynamics*** and ***Conceptual vehicle design***

At the division of Vehicle Engineering and Solid Mechanics

info@kth.se – accommodation, KTH user account, anything else.

master@sci.kth.se – study plans, courses, etc.

www.kth.se/en/studies/master/vehicleengineering

Presentation 7b:
***Chalmers, Mobility engineering Master
programme***
Dag Bergsjö, Chalmers

Presentation 7c:
LiU, Vehicle engineering courses
Jan Åslund, LiU

Vehicle Engineering Courses at Linköping University

Jan Åslund
Vehicular Systems

Road Vehicle Engineering at Linköping University

Selected Courses in Vehicle Systems

TSFS02 – Vehicle Dynamics and Control

Focus on the dynamic behavior of vehicles and their control systems.

TSFS03 – Vehicle Propulsion Systems

Explores different propulsion technologies used in road vehicles.

TSFS04 – Electric Drive Systems

Covers electric systems designed for vehicle propulsion.

TSFS09 – Modeling and Control of Engines and Drivelines

Introduction to modeling and control techniques for engines and drivetrain components.

TSFS12 – Autonomous Vehicles: Planning, Control, and Learning Systems

Development of autonomous vehicle technologies through planning, control, and machine learning.

TMME11 – Road Vehicle Dynamics

Provides knowledge on chassis components and simulation of road vehicle motion.

TSFS02 Vehicle Dynamics and Control

Examiner: Jan Åslund

Modern vehicles integrate an increasing array of autonomous and semi-autonomous functions, many of which are safety-critical—such as anti-lock braking systems (ABS), traction control, and electronic stability control (ESC).

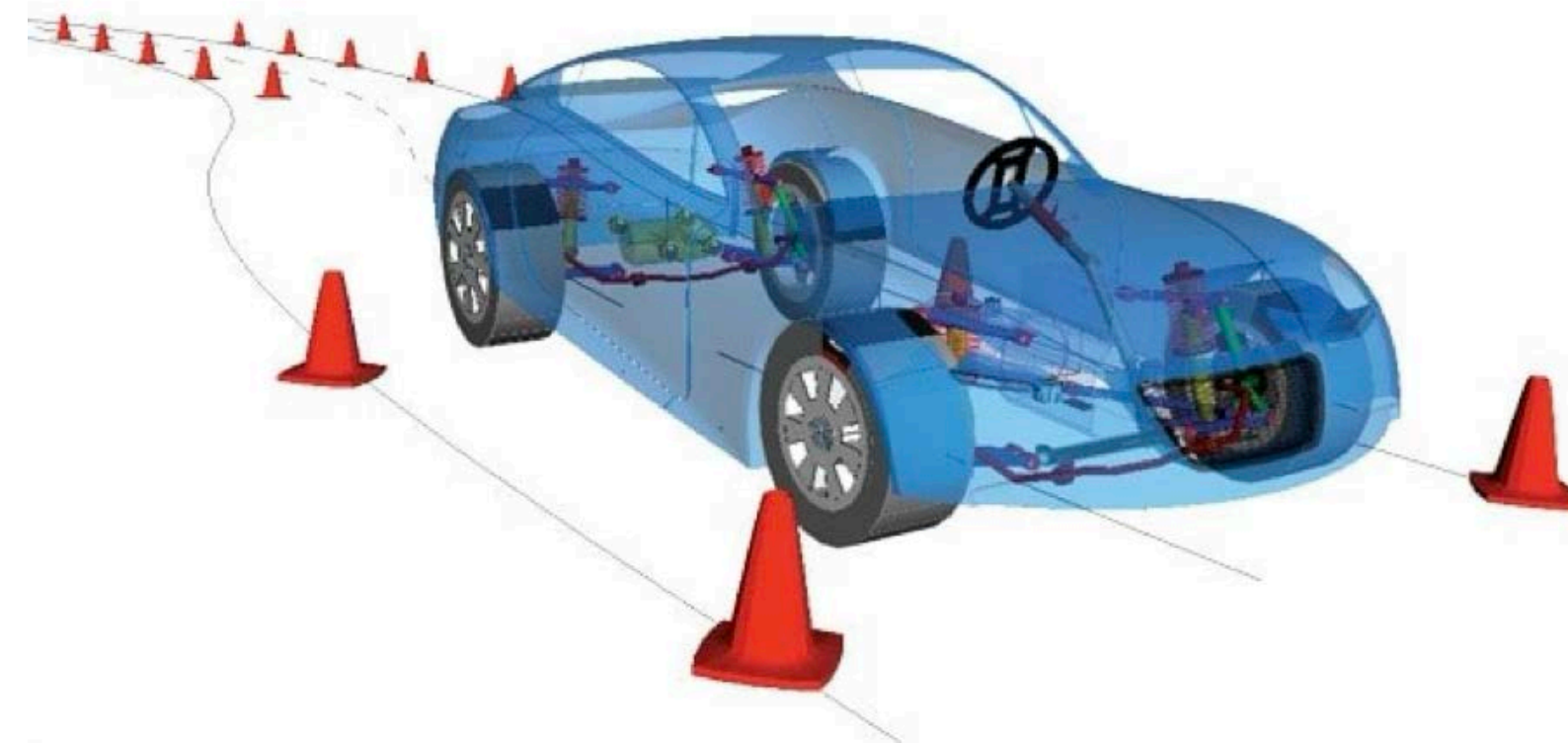

This course provides a foundational understanding of vehicle dynamics, including longitudinal, lateral, and vertical motion. Emphasis is placed on the modeling and analysis of dynamic behavior and the design principles of control systems that enhance vehicle safety, stability, and handling performance.

TSFS02 Laboratory Exercises in the Course

The course is examined through a written exam and the following five computer labs:

Brake Force Distribution & ABS

Study how brake force distribution and anti-lock braking systems affect vehicle dynamics and safety.

Cornering Dynamics

Parameterize and validate vehicle and tire models using real-world data.

Electronic Stability Control (ESC)

Develop and implement a control system to improve vehicle stability and safety.

Vertical Dynamics

Analyze how damper control influences passenger comfort and cornering performance.

Car-Trailer Stability Control

Design control strategies to ensure the stability of a car-trailer combination.

All course material is available at: <https://isy.gitlab-pages.liu.se/fs/courses/TSFS02/>

Don't hesitate to contact me if you have any questions: jan.aslund@liu.se

Poster 1:

***Reversing A-double using steerable axle on
the last semi-trailer***

Pavan Kumar Adiga Nagaraj, Niveditha
Krishnakumar, Chalmers and Volvo Trucks

V O L V O

Reversing A-double using steerable axle on the last semi-trailer

SEVA presentation

Masters Student: Pavan Kumar Adiga Nagaraj, Niveditha Krishnakumar

Industrial Supervisor: Mukesh Choudhary

Academic Supervisor: Zhaohui Ge

Examiner: Bengt Jacobson

Week 19

Volvo Group

VMM | Mid-term presentation - Reverse assist for LCV | Internal

2025-05-06

Agenda

- Introduction
- Research questions of thesis
- Low Speed reverse assist function overview
- Modeling overview and model verification
- Controller overview and controller verification with VTM
- Test cases and controller validation in VTM
- Results

Introduction

Reversing of Long combination vehicle (LCV):-

vehicle combination : A- double combination

number of articulation angles: 3

reversing complexity increases as the number of articulation angles increases.

- Truck FH 4X2 are the highest sold in europe which is generally combined with just a single semi-trailer.
- Truck FH 6x4 / FH 6X2 are the next best sold truck configuration which is suitable for LC.
- In Nordic countries A-double and AB double combination was first introduced in Finland in 2019. Followed by Sweden in december 2023 officially allowing up to 34.5m.
- Intended application low speed maneuver reverse ($V_x = -3.6$ km/h)
- Based on the experience, reversing an A-double for 10m straight was difficult

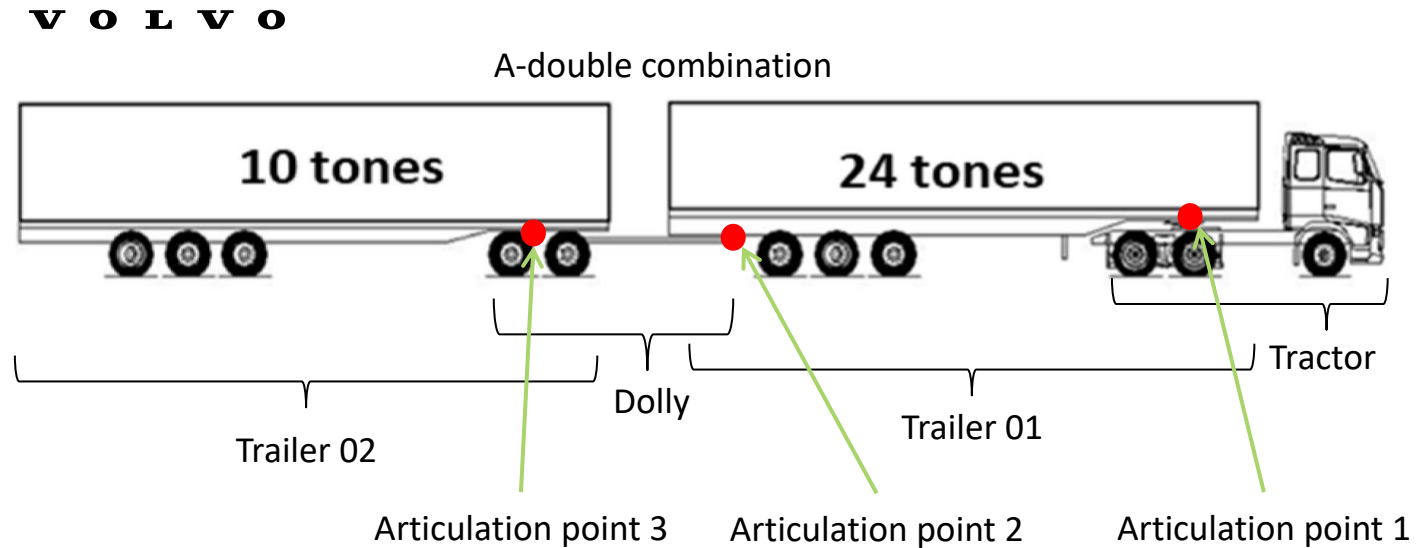

Research Questions of Thesis

1. Research A-double reversing and collect Tommi's feedback with a vehicle demo
2. Develop a control algorithm to automate steering for reversing.
3. Explore reversing using only
 - Tractor steering
 - Tractor and trailer 2 last axle steering
4. Analyze the impact of loaded vs. unloaded last trailers during reversing.
5. Test the control algorithm on a test vehicle.
6. Integrate outputs with the HMI display to provide driver feedback.



Function overview



Knob to set the desired trajectory

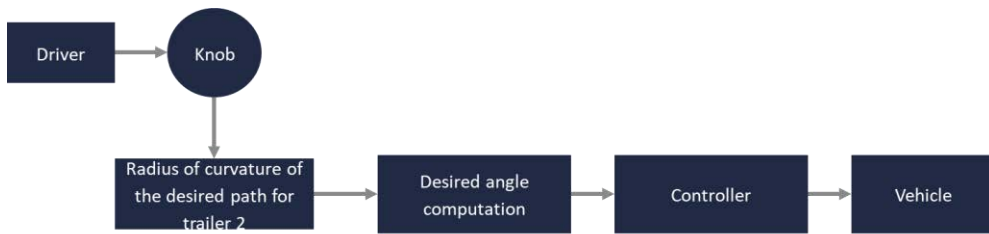

V O L V O

A-Combination top view

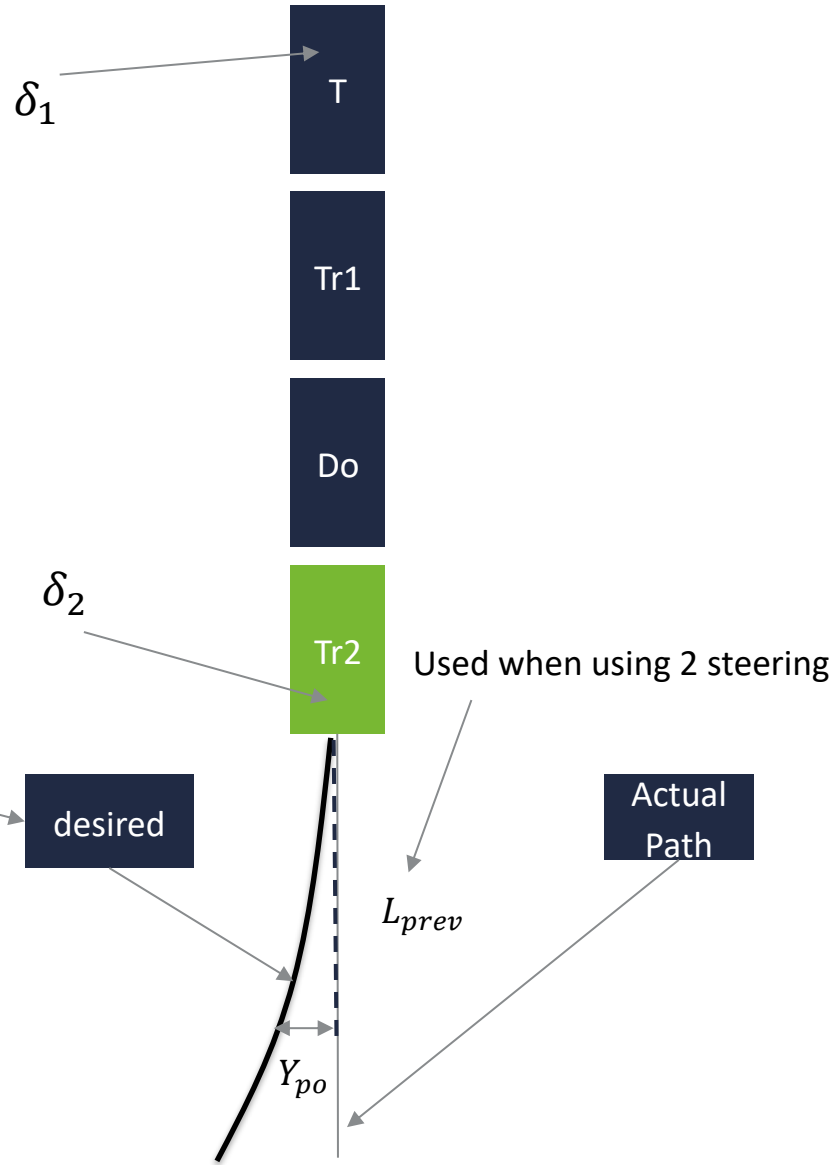

HMI

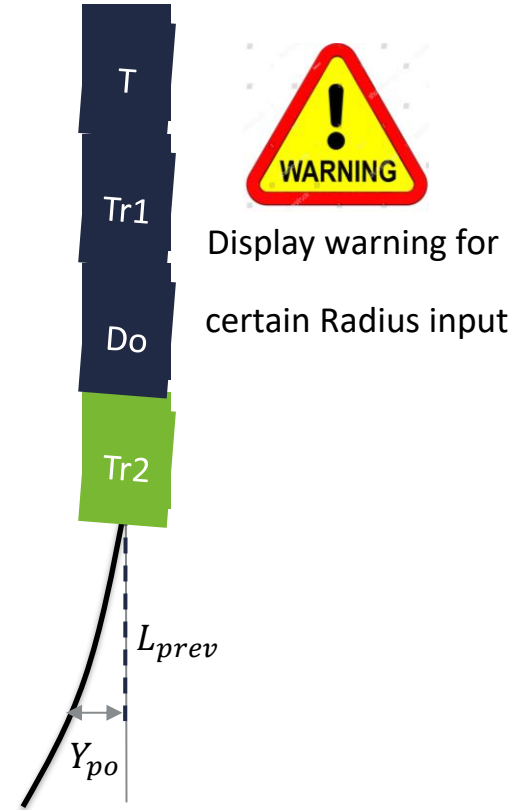

Modelling

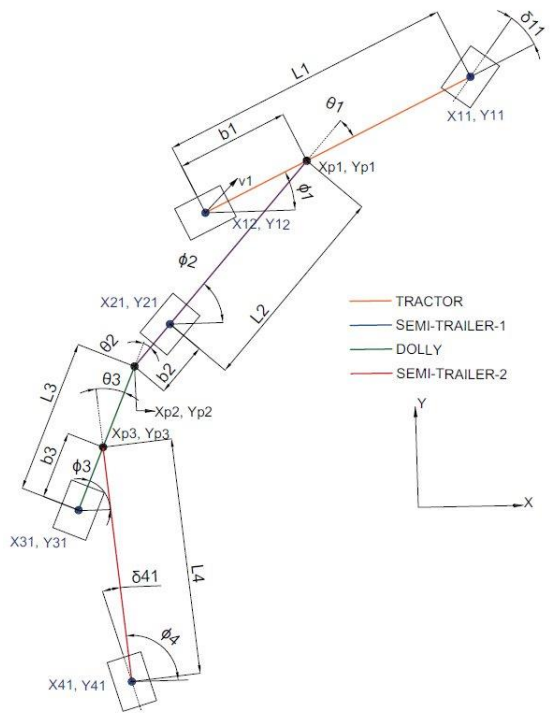

Model Verification

Results : OK

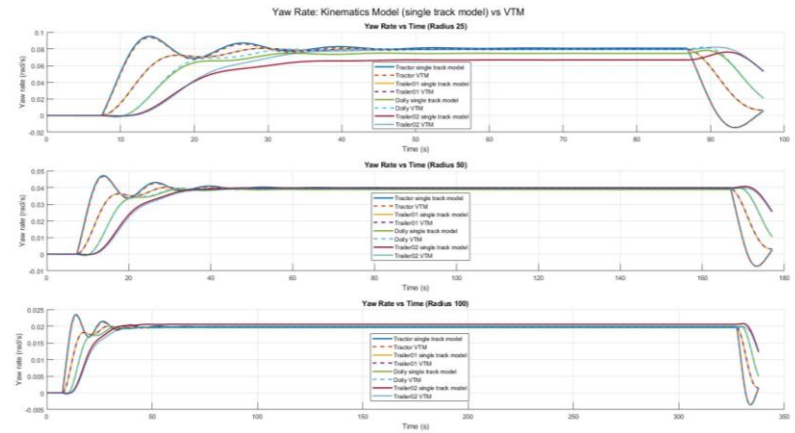

Vehicle was moving in Forward direction with the velocity of 2m/s

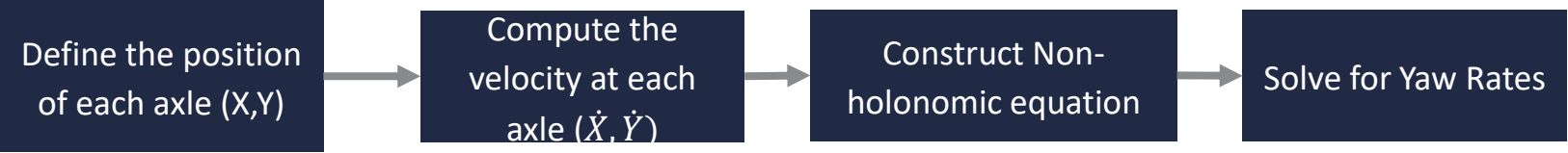

Differentiate position w.r.t time

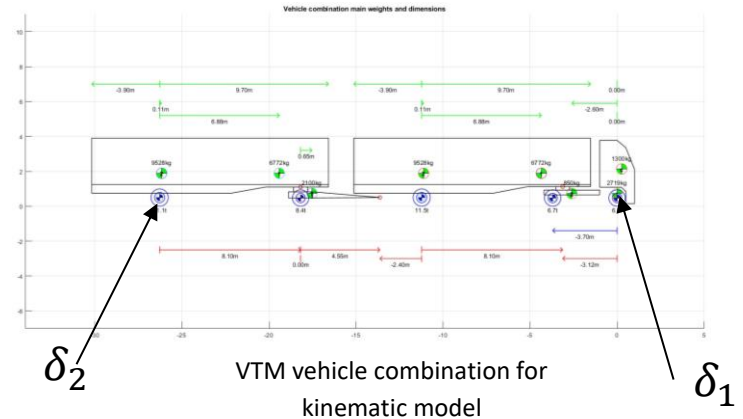

VTM vehicle combination for kinematic model

- Combination length – 31.5m; Track width -2.5
- Number of axles – 5 (lumped axles on all units)
- Steerable Axles: Tractor, Trailer 2
- Propelled Axles: Tractor

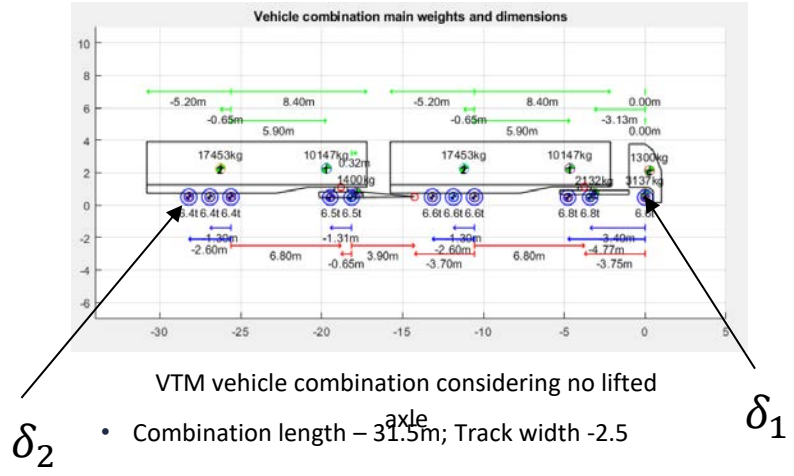

VTM vehicle combination considering no lifted axle

- Combination length – 31.5m; Track width -2.5
- Number of axles – 11 (no lifted axle)
- Steerable Axles: Tractor, Trailer 2
- Propelled Axles: Tractor

Controller Overview

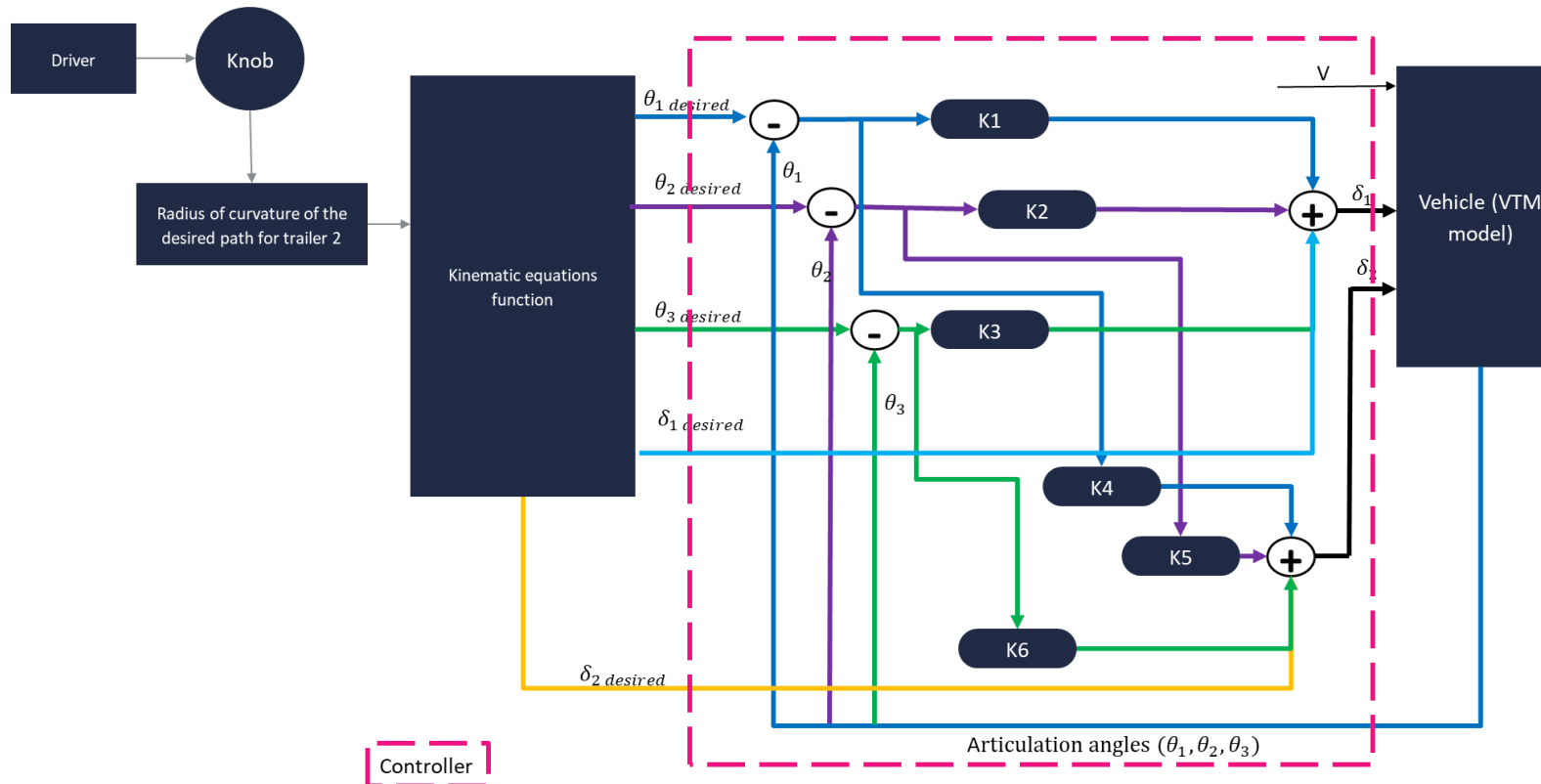

Controller Verification test case (circle radius 30 m)

Results : OK

Vehicle was reversing at 1m/s

Radius 30m, all axle considered

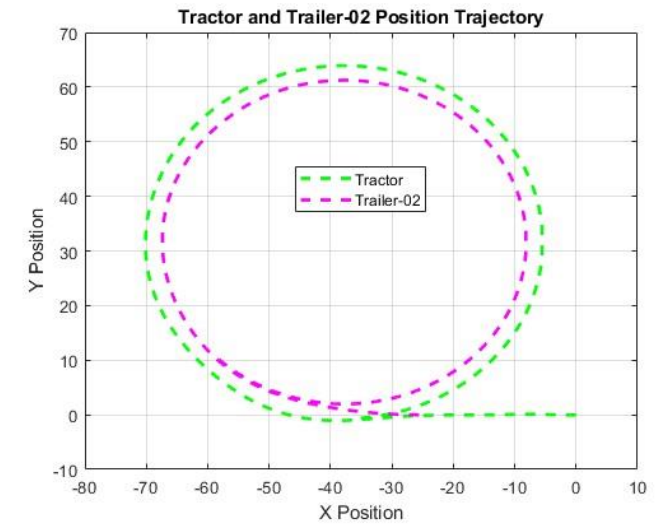
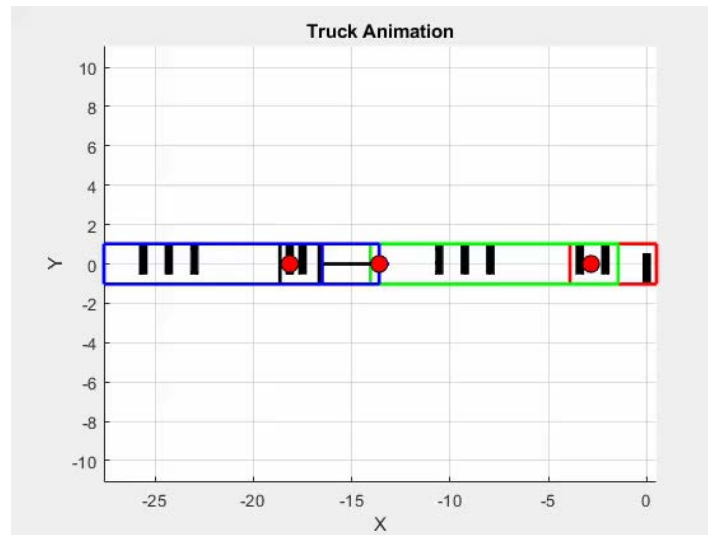
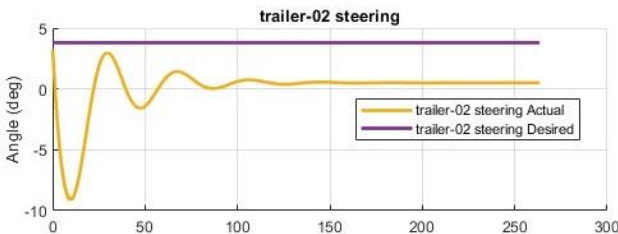
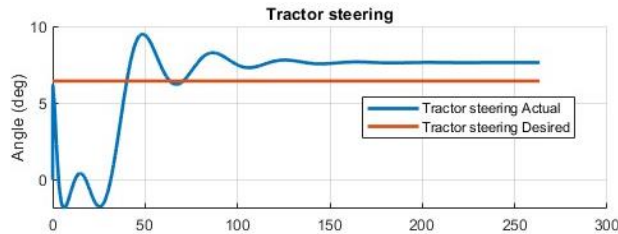
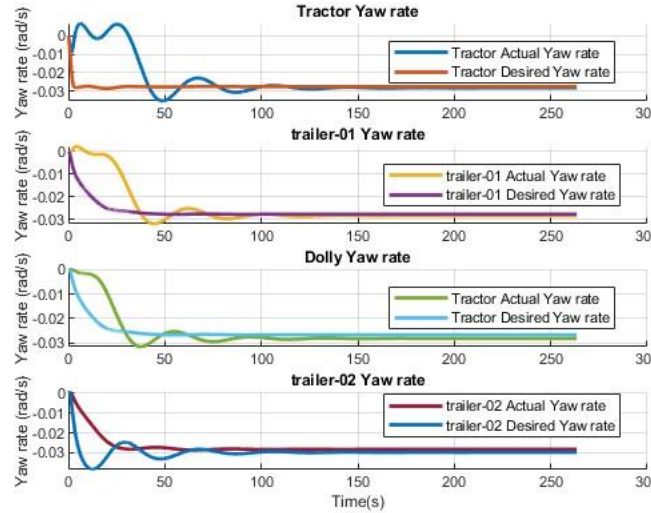
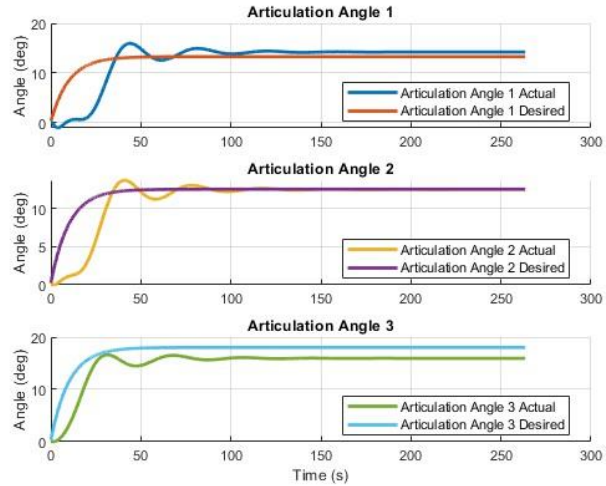

Controller Verification test case (straight line 200m)

Results : OK

Vehicle was reversing at 1m/s

Straight line 200m , all axle considered

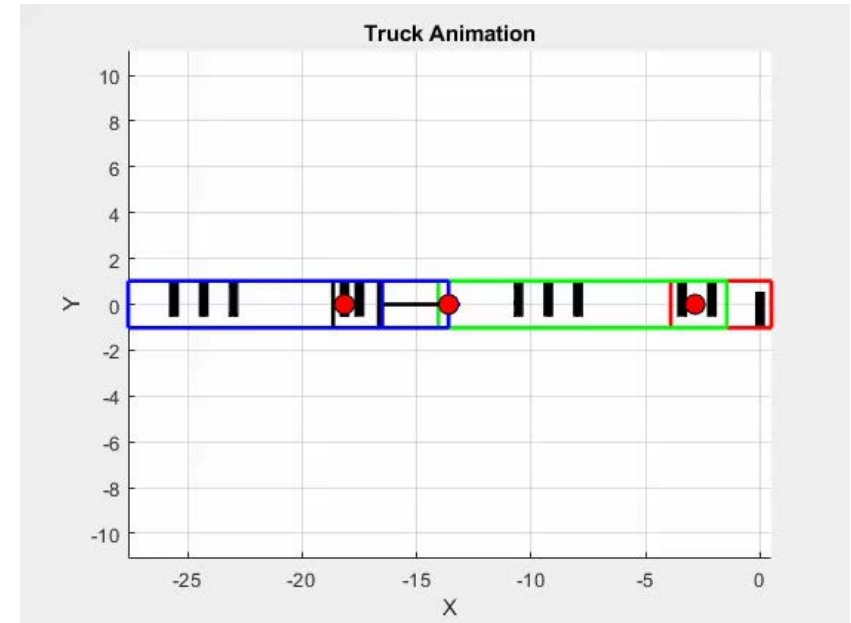
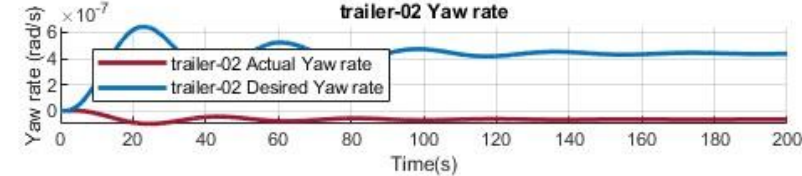
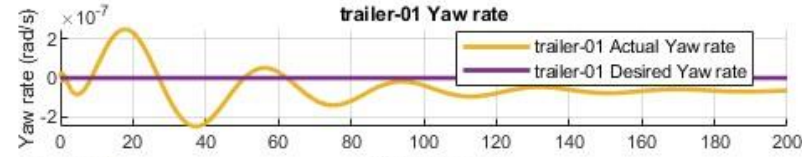
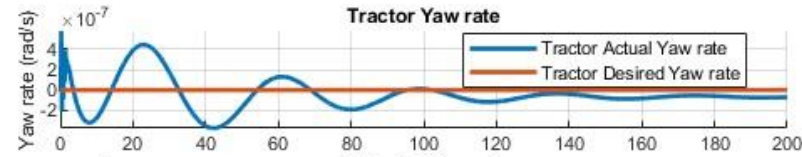
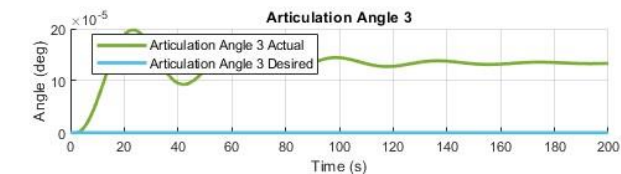
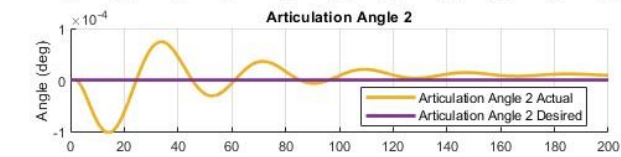
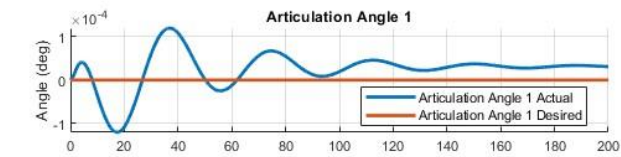
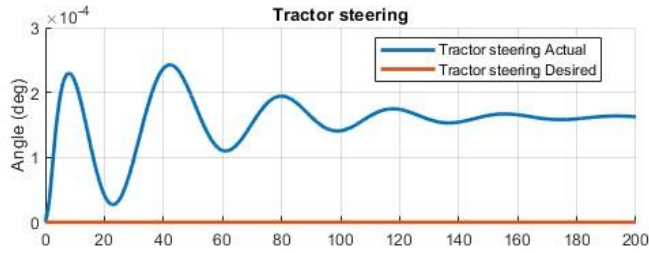

Questions and feedback

Reversing A-double using steerable axle on the last semi-trailer

Pavan Kumar Adiga, Niveditha Krishnakumar

Introduction

- Reversing of Long combination vehicle (LCV):-
 - ❑ Vehicle combination : A- double combination
 - ❑ Number of articulation angles: 3
 - ❑ Reversing complexity increases as the number of articulation angles increases.
- Intended application low speed maneuver reverse ($V_x = -3.6$ km/h)
- Based on the vehicle test drive it was identified that reversing an A-double for 10m straight was difficult

Research questions

- Research A-double reversing and collect Tommi's feedback with a vehicle demo
- Develop a control algorithm to automate steering for reversing.
- Explore reversing using only
 1. Tractor steering
 2. Tractor and trailer 2 last axle steering

Modelling approach

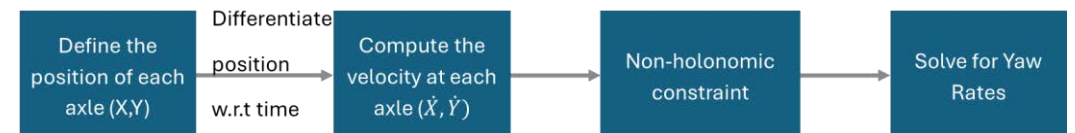
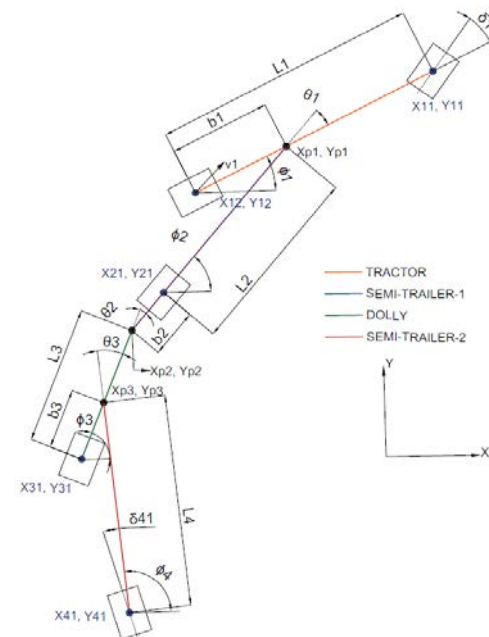
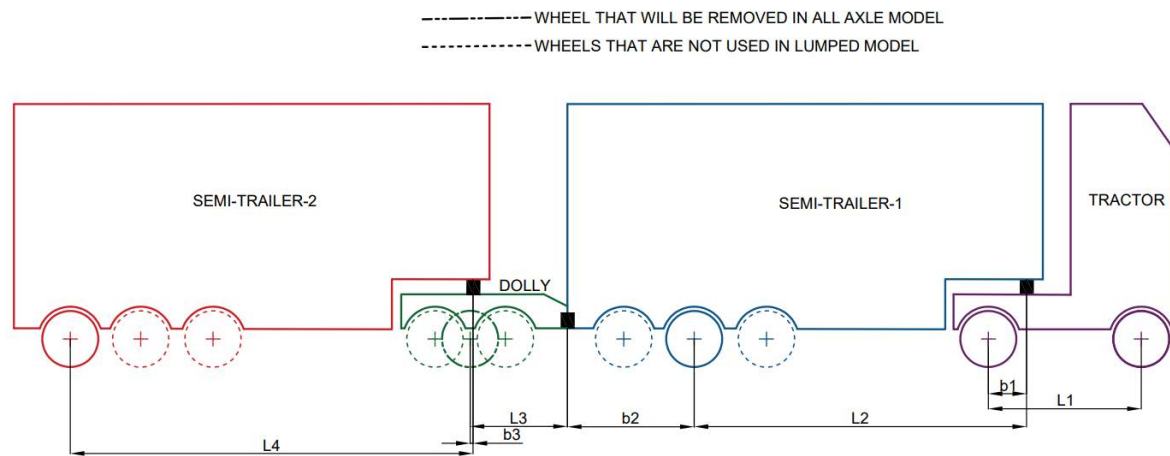



Reversing A-double using steerable axle on the last semi-trailer

Pavan Kumar Adiga, Niveditha Krishnakumar

Function overview

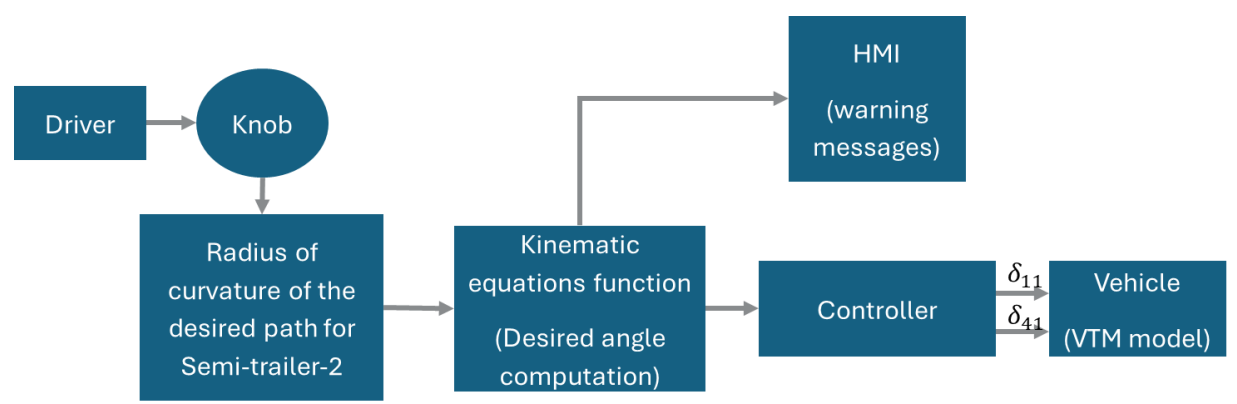

Feedback Controller

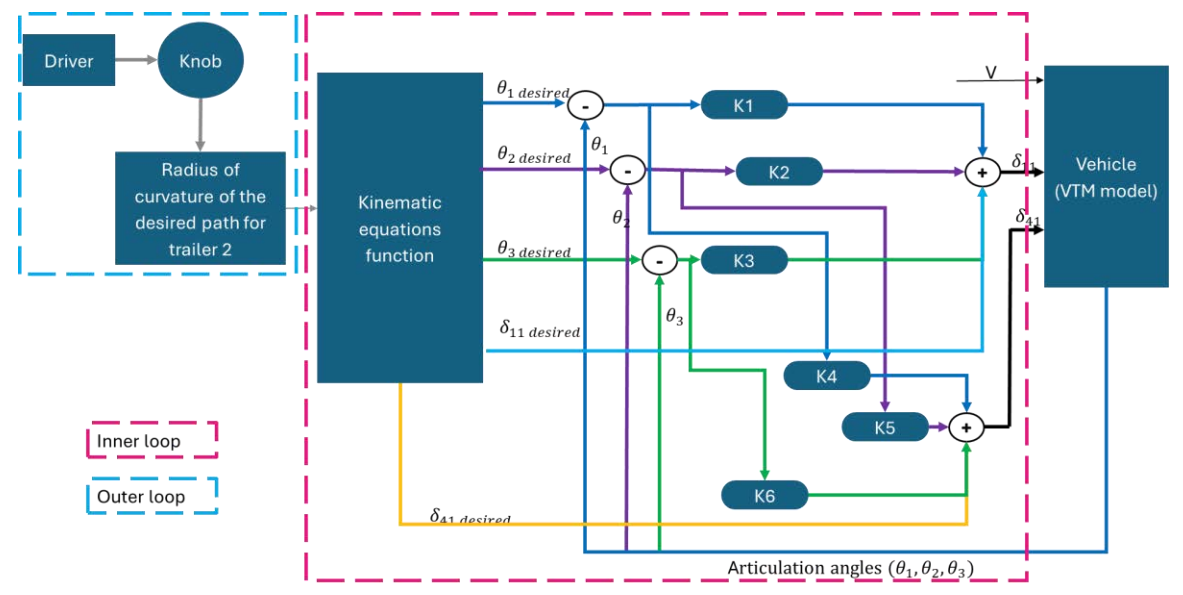
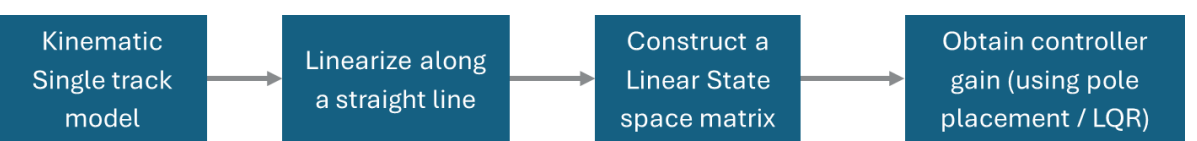

Results

Reversing of A double combination with tractor steering for a straight line



Trajectory

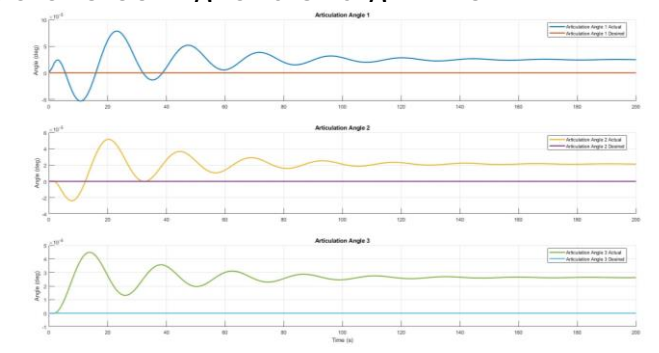

Articulation Angle

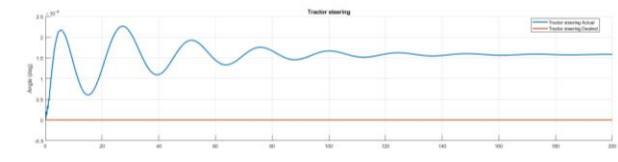

Steering Angle

Reversing of A double combination with tractor and trailer -02 last axle steered for straight line

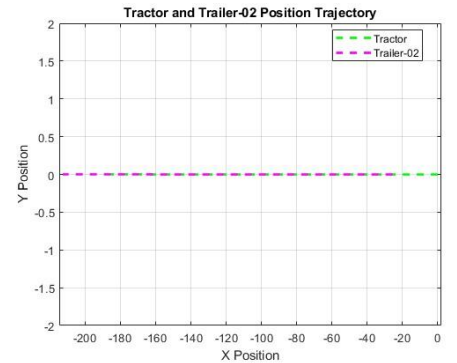

Trajectory

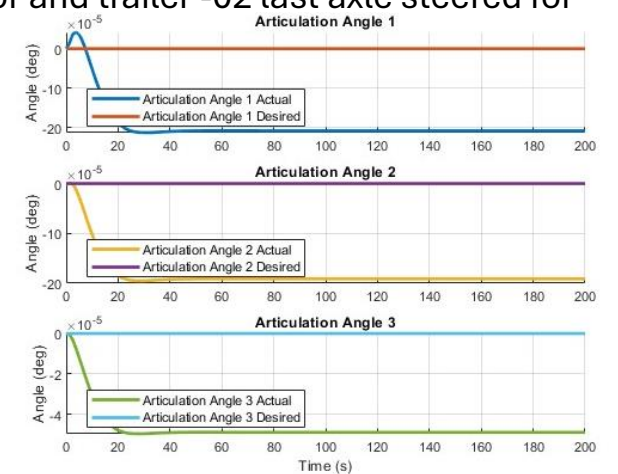

Steering Angle

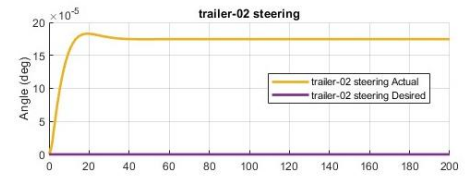
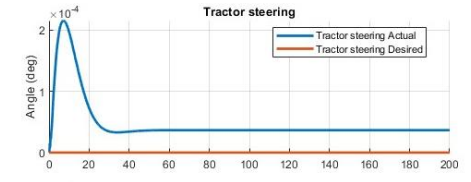

Articulation Angle

Poster 2:

***Onboard Estimation of Center of Gravity in
Heavy Vehicles***

Alfred Aronsson and Fabian Fagerlind,
Chalmers and Volvo Trucks

This poster was unfortunately cancelled

Poster 3:

Development and validation of a friction estimation model for collision avoidance maneuvers in autonomous trucks

Ganapati Girish Kamat, Chalmers and Scania



Ganapati Girish Kamat

Development and validation of a friction estimation model for collision avoidance manoeuvres in autonomous trucks



About me



- Born and raised in Bangalore, India
- Education:
 - Masters in Mobility Engineering (Automotive track) @ Chalmers University
 - Bachelors in Mechanical Engineering @ BMS College of Engineering, India
- Scania Student Intro 2024
 - Summer intern @ steering design team
 - Master thesis student @ ADAS & autonomous steering functions team
- Hobbies: I enjoy playing volleyball and hiking

Introduction



- Autonomous trucks need reliable collision avoidance systems for safety
- Information on peak friction coefficient is crucial to determine braking and steering limits
- Challenge: Traditional methods assume a fixed friction coefficient, leading to suboptimal manoeuvres



Introduction



- Envisioned solution: To develop a friction estimator model based on logged signal data and use the estimated value of peak friction coefficient in a collision avoidance system
- Limitations
 - Scenario in consideration – only two road users, truck and static obstacle on a two-lane road
 - 4*2 tractor truck to be controlled
 - No vision-based or specialised direct friction sensors to be used in friction estimation
 - Testing carried out at Scania test track in dry conditions



Theory – slipslope method of friction estimation

- Longitudinal dynamics-based method
- Uses recursive least squares algorithm (RLS) to estimate the slipslope (CC_x) [1]
- Wheel speeds, axle load and longitudinal acceleration signal data extracted from log data

RLS governing equation

$$y(t) = \phi(t) \cdot \theta(t) + e(t)$$

For low slip,

$$F_x = CC_x (\alpha \cdot F_{zf} \cdot s_{xf} + F_{zr} \cdot s_{xr}) \quad (1)$$

$$\phi(t) = \alpha \cdot F_{zf} \cdot s_{xf} + F_{zr} \cdot s_{xr} \quad (\alpha = 0 \text{ for RWD and acceleration, } \alpha = 1 \text{ during braking})$$

$$\theta(t) = \text{estimated } CC_x$$

$$\mu = CC_x \cdot s_x$$

For high slip,
 $F_x = \mu \cdot F_z \quad (2)$

$$\phi(t) = F_{zf} + F_{zr}$$
$$\theta(t) = \text{estimated } \mu$$

RLS algorithm

$$e(t) = y(t) - \phi(t) \cdot \theta(t-1)$$

$$K(t) = \frac{P(t-1) \cdot \phi(t)}{\lambda + \phi^2(t) \cdot P(t-1)}$$

$$P(t) = \frac{1}{\lambda} \left[P(t-1) - \frac{P^2(t-1) \phi^2(t)}{\lambda + \phi^2(t) \cdot P(t-1)} \right]$$

$$\theta(t) = \theta(t-1) + K(t) \cdot e(t)$$

Preliminary results - friction estimator



- Truck tests conducted for logging data
- Necessary signals extracted and filtered as required from log data (extracted using CANalyzer)
- MATLAB code developed to estimate peak friction coefficient based on the log data sets
- Estimated peak friction coefficient converges to 0.74

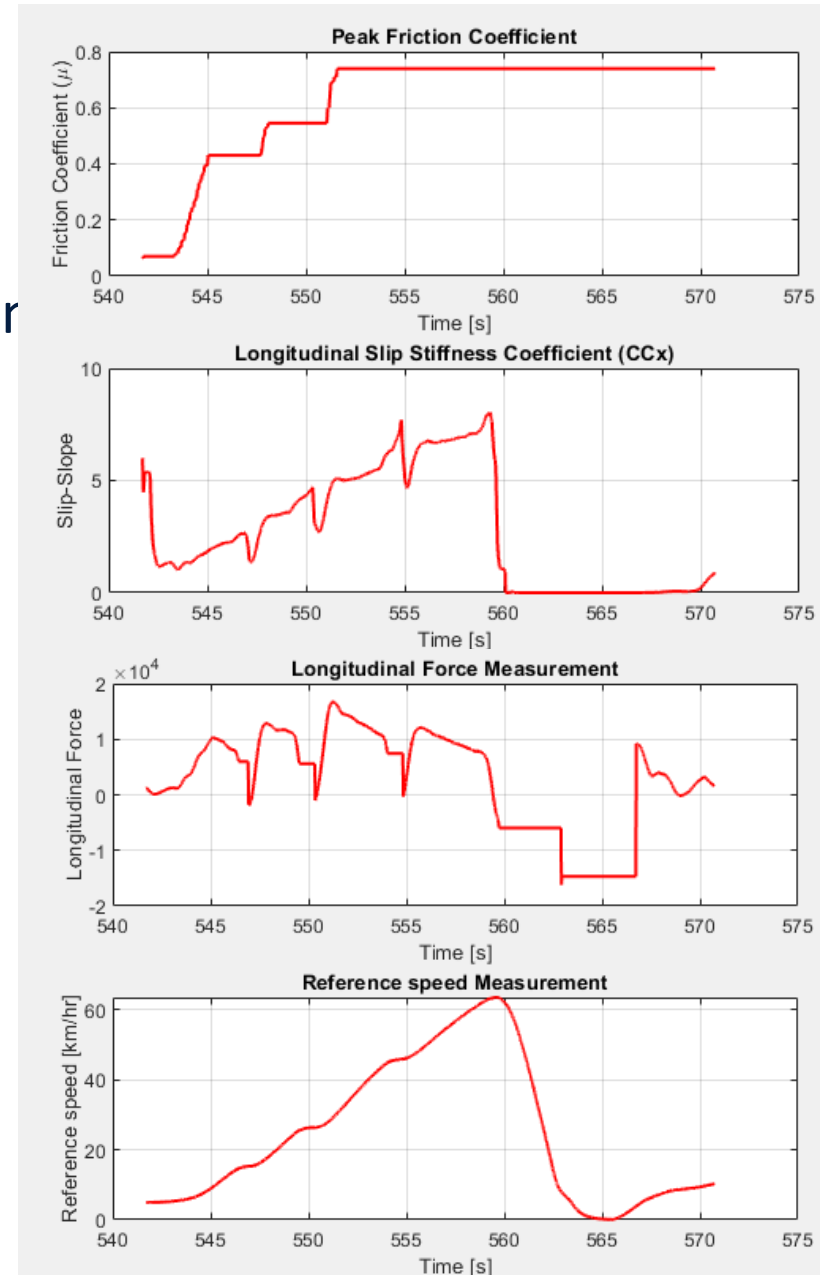



Simulation setup & implementation – CA system

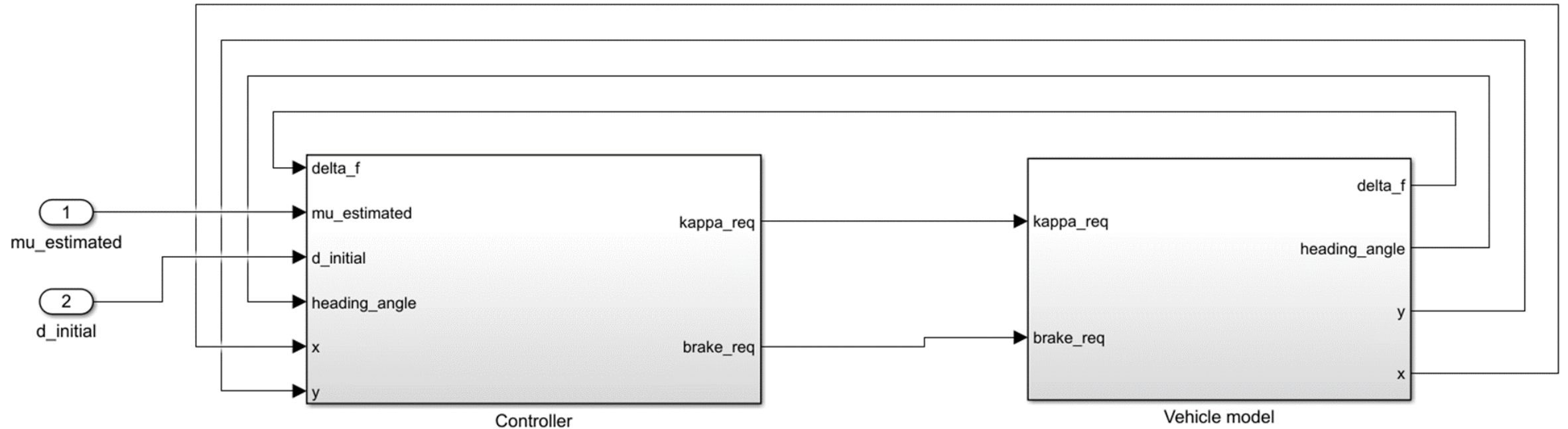



Test Plan

- 2 test cases to run – pure braking, brake and steer
- First reach required initial speed then perform the manoeuvre according to test case
- Data to be logged: front wheel angle, speed, lateral acceleration, trajectory of the truck



Preliminary results

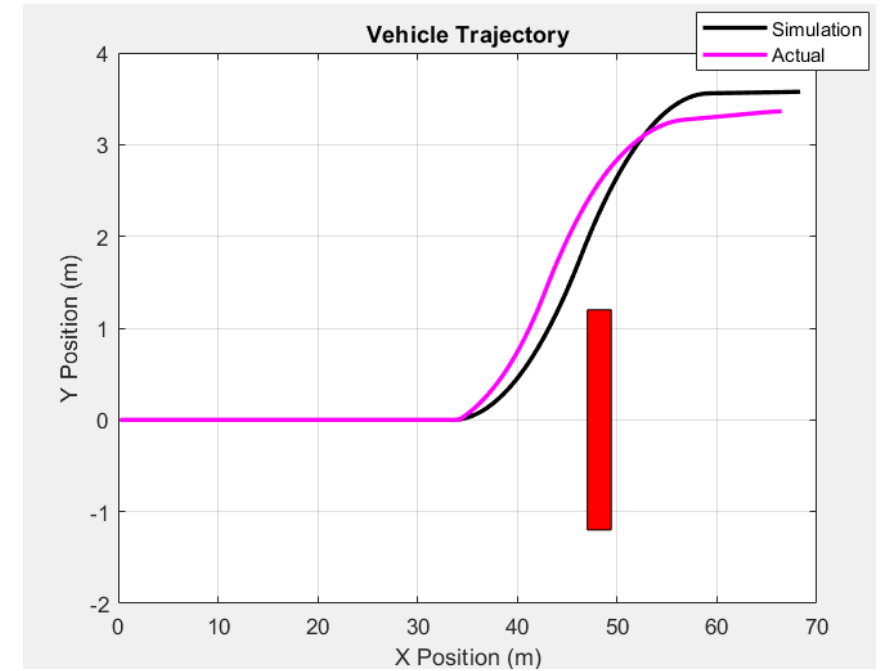
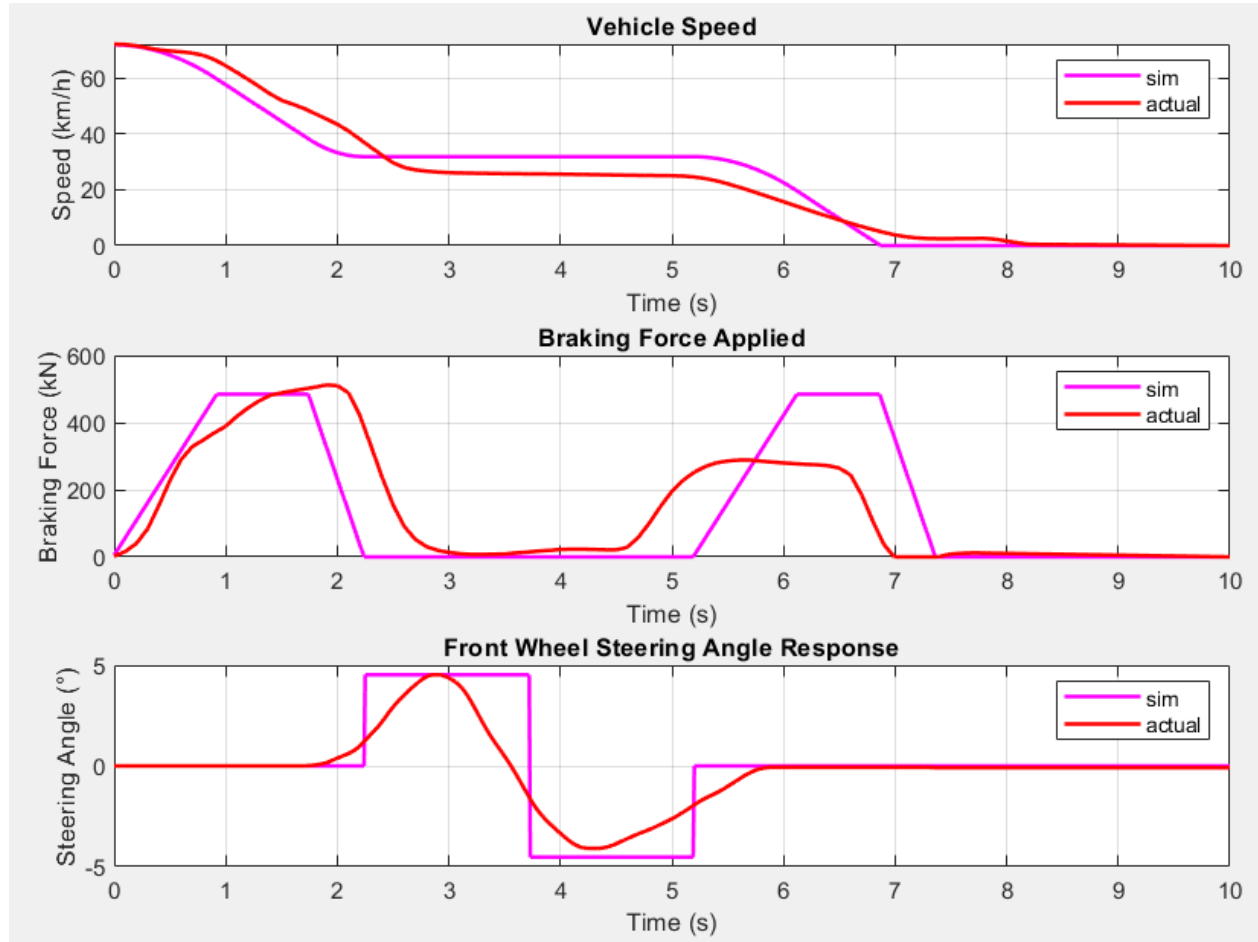



Future work

- Testing with different surfaces and in different conditions
- Integrate friction estimator with the CA system to give updates on μ value in real time
- Include trailer and account for trailer dynamics

For any questions, write to me at ganapati.g.kamat@gmail.com



**Thank you for
listening!**

Poster 4:

***Physics-Informed Neural Networks for
Vehicle Lateral Dynamics Modelling***

Rishikesh Vishnu Sivakumar, Yuchuan Dong,
Chalmers and Zeekr



Physics-Informed Neural Networks for Vehicle Lateral Dynamics modelling

Master Student: Yuchuan Dong & Rishikesh Vishnu Sivakumar

Industry Supervisors: Utsav Khan & Karthik Prasad

Academic Supervisor: Fredrik Bruzelius

Z E E K R



Accurate real-time knowledge of a vehicle's lateral dynamics is pivotal for safe automated driving, precise motion control, energy-efficient control and robust trajectory planning.

In this study, we combined **Deep Neural Network** with **Physical Laws** to model Lateral Dynamics.



Existing approaches include:

- **Physics-based methods** (e.g., Bicycle model, Pacejka tyre formula)
 - + Transparent and interpretable
 - Require accurate tyre and vehicle parameters (often unknown or hard to measure)
- **Purely data-driven methods** (stacked Long Short-Term Memory/Gated Recurrent Unit)
 - + Learn directly from data, capturing complex dynamics
 - Black-box models without physical insights
 - Inferring unobservable states needs expensive measurement equipments and lot of vehicle tests(e.g., lateral velocity, tyre coefficient or friction.)
- **Physics-Informed Neural Network** (e.g. Deep Dynamics)
 - + Combines physics and learning effectively
 - Relies on expensive and complicated to measure inputs (e.g., lateral velocity), reducing practical utility

Our method (*PhysAttenderNet*) integrates physics information and attention-based neural networks, enabling inference of latent states and achieving accurate, physically-consistent estimations.

Our method accurately infers unobservable variables—including **lateral velocity** and **tyre coefficient**—and cuts state-estimation errors relative to purely data-driven method.



PhysAttenderNet

Physics and Attention Attend into Network.

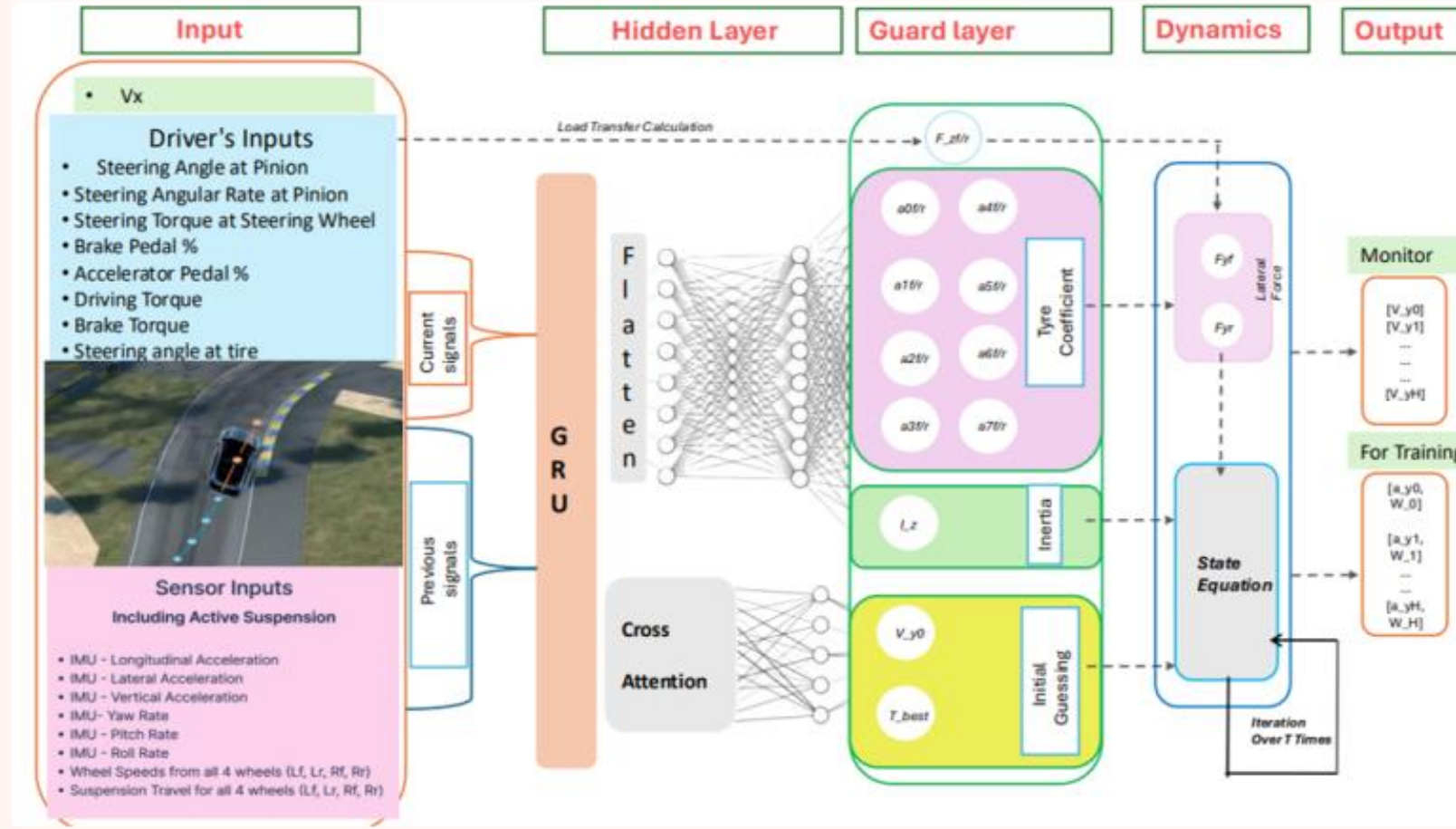

Dynamics Part in Detail

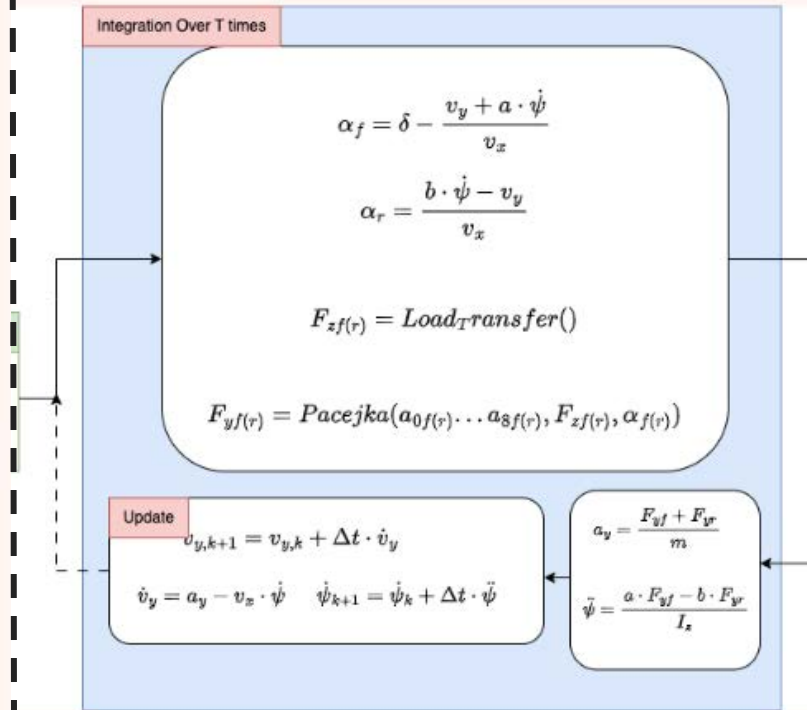



Ground truth vs. Data-Driven-NN& PhysAttenderNet predictions in Simulation Dataset from CarMaker

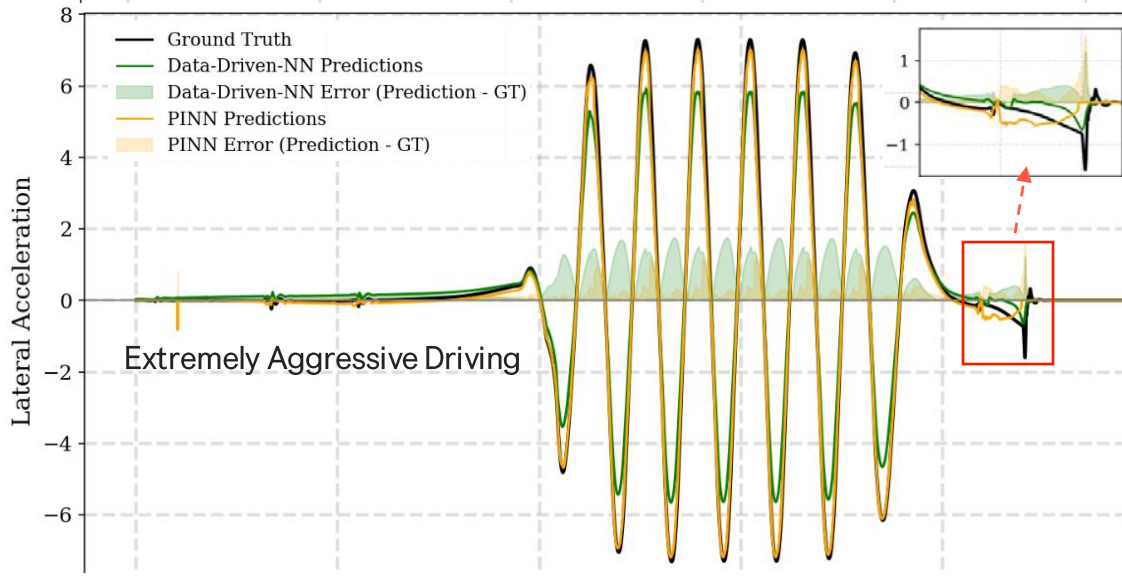
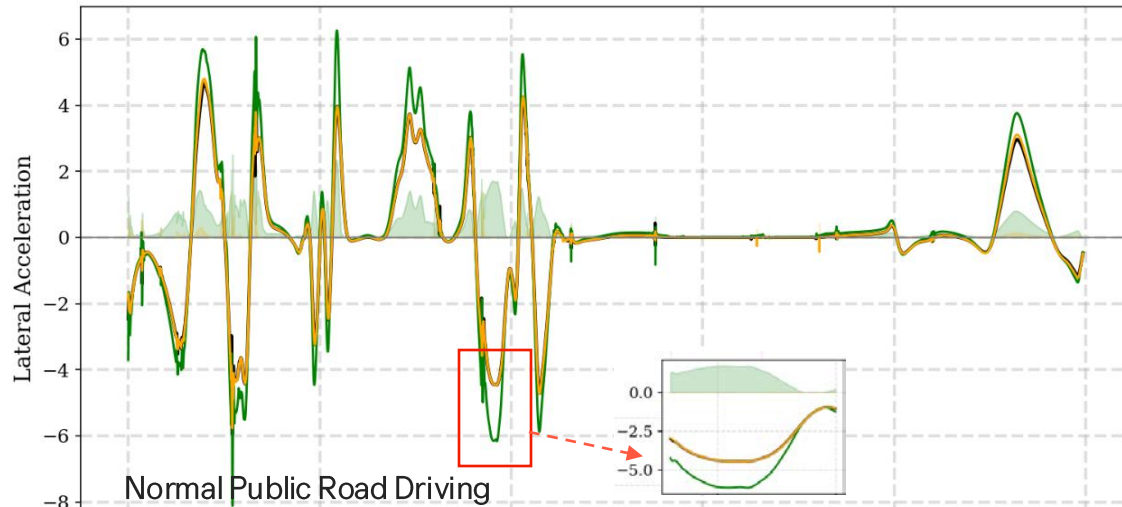

Prediction and Error on Lateral Acceleration(m/s²)

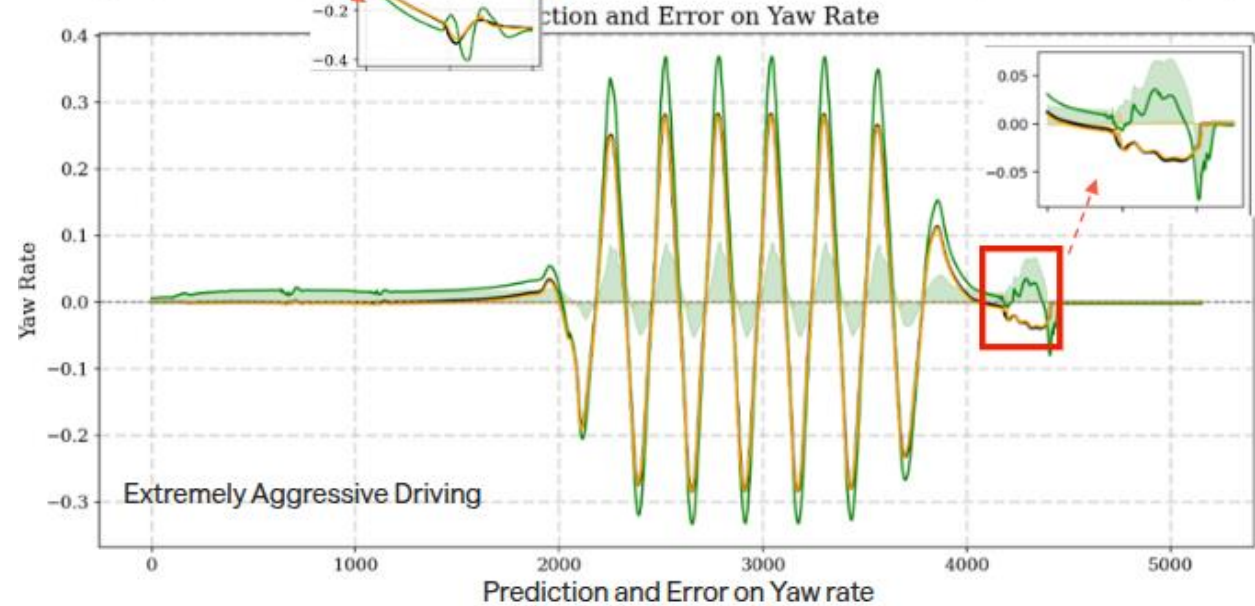
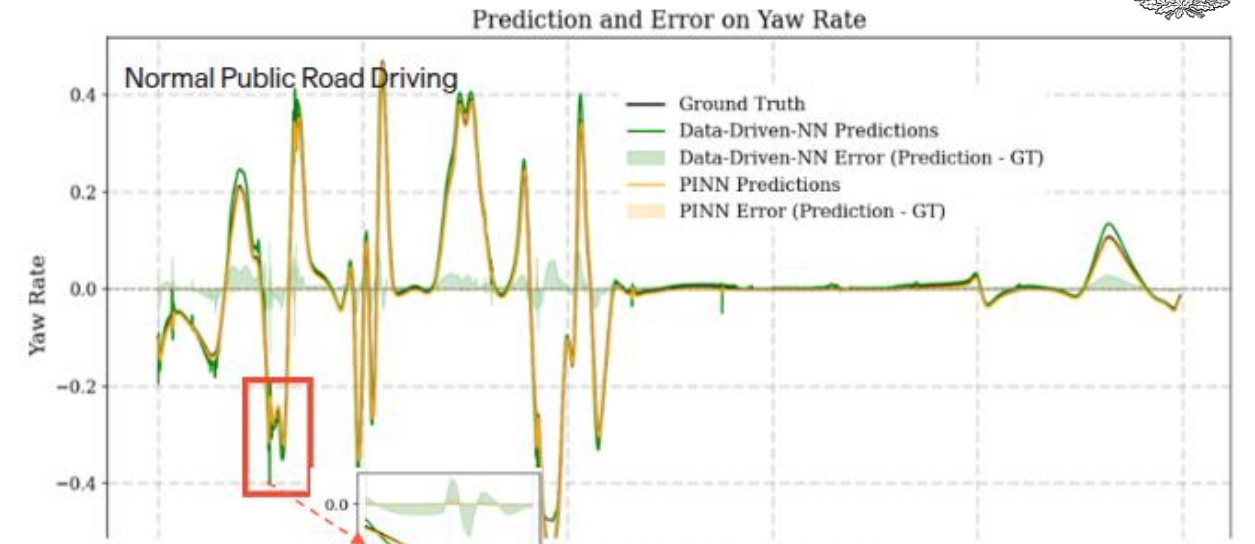

Prediction and Error on Yaw rate



Solving the 'Impossible': PhysAttenderNN Predicts Lateral Velocity Where Data-Driven-NN Can't

- PhysAttenderNN benefit from attention mechanism and embedded ODE, make it possible to estimate/predict lateral velocity.
- Only good lateral velocity estimation lead lateral acceleration and yaw rate result.

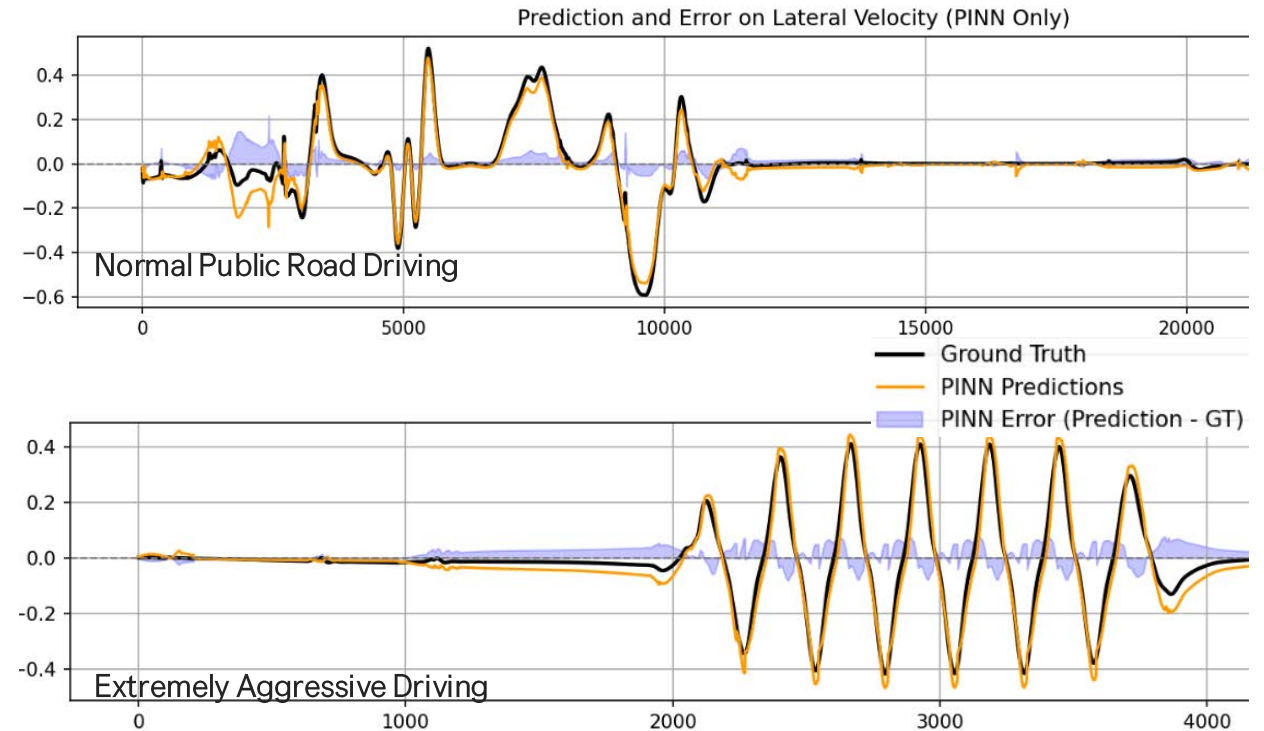

RMSE Comparison (Normal + Aggressive Driving)

Model	Lateral Acc. a_y (m/s ²)	Yaw Rate $\dot{\psi}$ (rad/s)	Lat. Vel. v_y (m/s)
Purely Data-Driven (LSTM)	0.493+0.648	0.0167+0.0303	—
<i>PhysAttenderNet</i>	0.0664+0.243	0.00257+0.0023	0.0389+0.0723

Table 1. Root Mean Square Error (RMSE) comparison. Lower is better. v_y not available from data-driven model.



Thanks for Listening

Overview

Accurate real-time knowledge of a vehicle's lateral dynamics is pivotal for safe automated driving, precise motion control, energy-efficient control and robust trajectory planning.

In this study, we combined **Deep Neural Network** with **Physical Laws** to model Lateral Dynamics.



Our method accurately infers unobservable variables—including **lateral velocity** and **tyre coefficient**—and cuts state-estimation errors relative to purely data-driven method.

Background: Model families

Existing approaches include:

- **Physics-based methods** (e.g., Bicycle model, Pacejka tyre formula)
 - + Transparent and interpretable
 - Require accurate tyre and vehicle parameters (often unknown or hard to measure)
- **Purely data-driven methods** (stacked Long Short-Term Memory/Gated Recurrent Unit)
 - + Learn directly from data, capturing complex dynamics
 - Black-box models without physical insights
 - Inferring unobservable states needs expensive measurement equipments and lot of vehicle tests(e.g., lateral velocity, tyre coefficient or friction.)
- **Physics-Informed Neural Network** (e.g. Deep Dynamics)
 - + Combines physics and learning effectively
 - Relies on expensive and complicated to measure inputs (e.g., lateral velocity), reducing practical utility

Our method (*PhysAttenderNet*) integrates physics information and attention-based neural networks, enabling inference of latent states and achieving accurate, physically-consistent estimations.

Workflow & Method

Training Pipeline

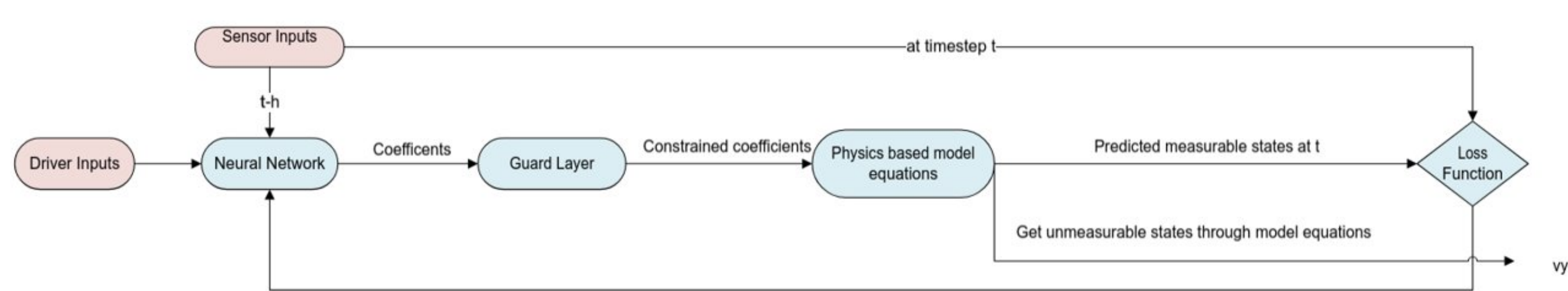

- **Sensor Measurements and Driver Commands** collected (IMU, wheel speeds, suspension travel, etc.)
- **Neural Network** predicts ODE parameters guided by domain knowledge constraints.
- **Single Track ODE Model** simulates vehicle dynamics.
- **Loss Function**: Minimizes difference between predicted and actual sensor states(Only take lateral acceleration and yaw rate).
- Outputs **unobservable states** (e.g., lateral velocity v_y), and enables estimation of model parameters.

Inference Pipeline

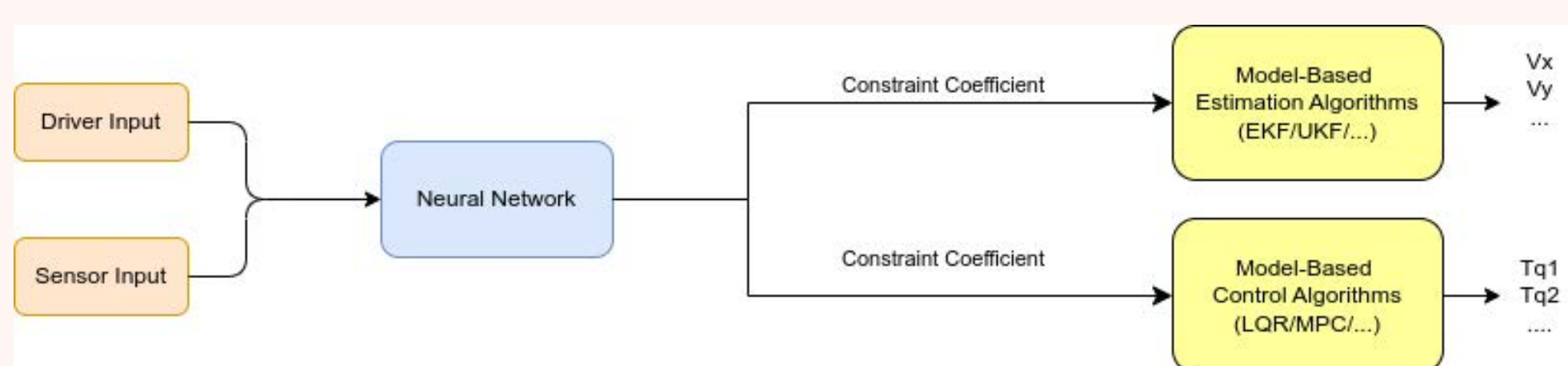

- **Estimate Constraint coefficient only**
- **Integration** into downstream estimators and controllers (e.g., UKF, MPC).

Method

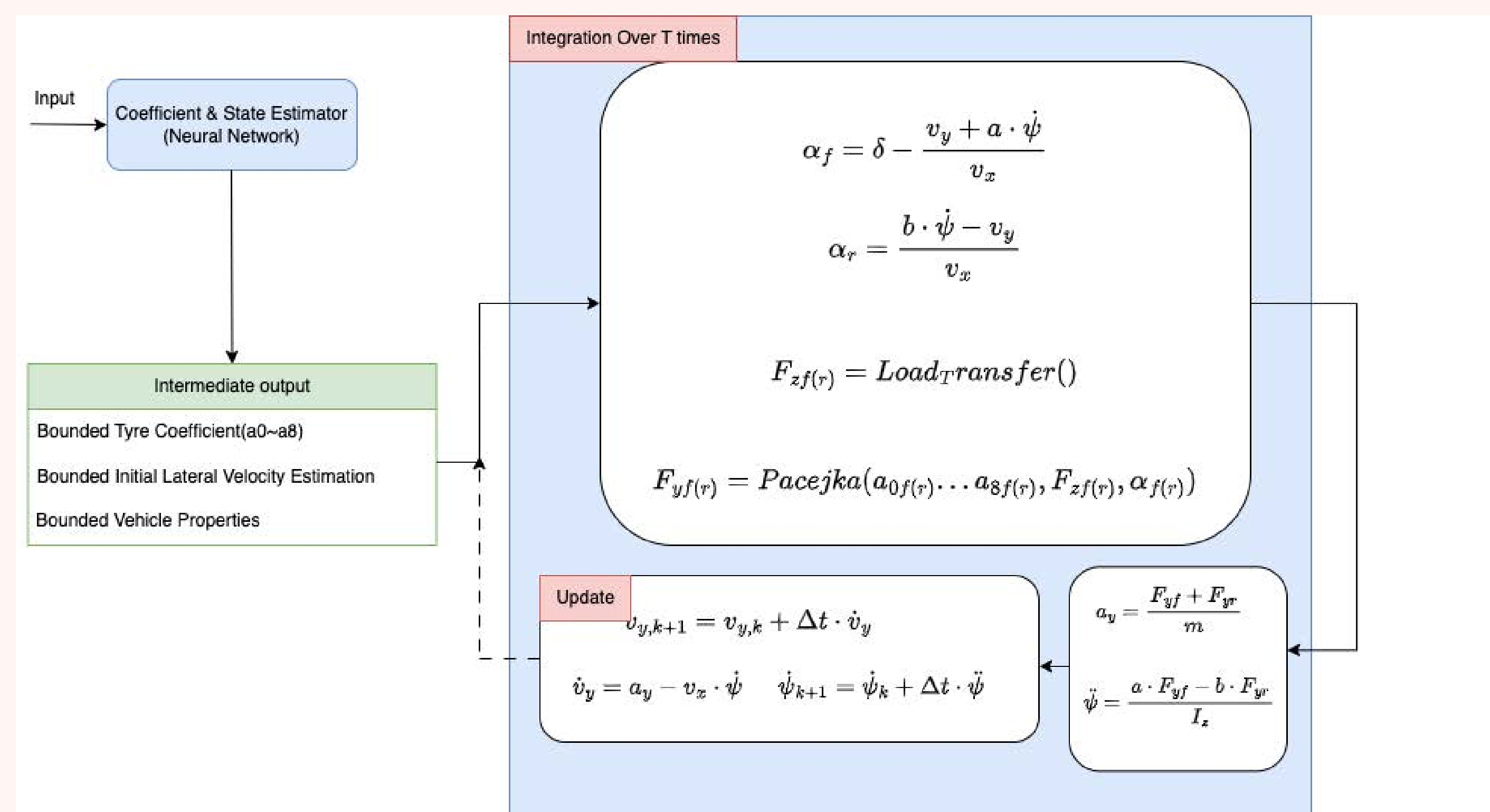

PhysAttenderNet

Physics and Attention Attend into Network.

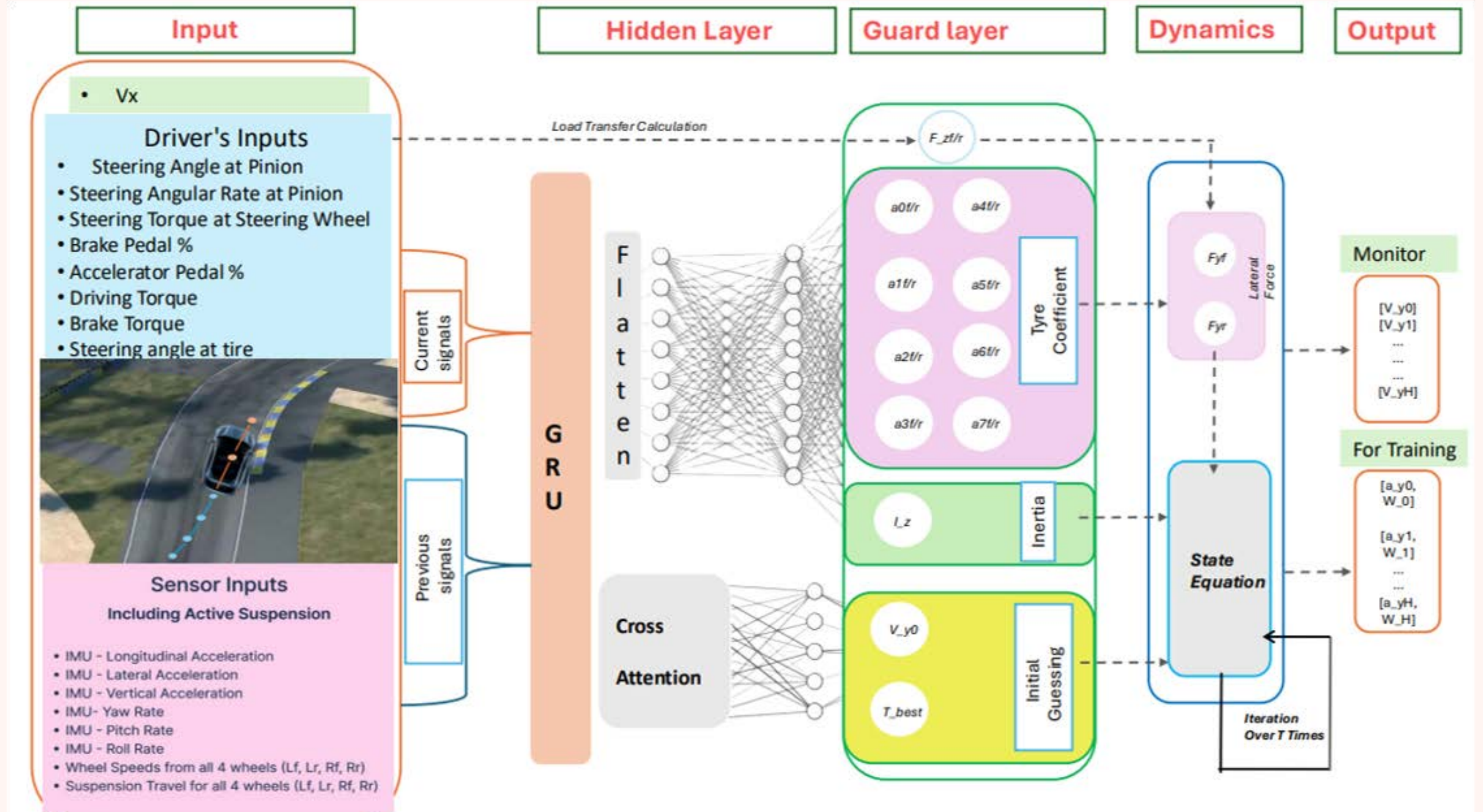

- **Input**. 50-step window of driver commands + sensor signals. *What do we feed the net?*
- **GRU Encoder**. Learns temporal patterns. *How are past moments related?*
- **Cross-Attention**. Picks the most informative instants to make estimation. *When should we focus?*
- **Guard Layer**. Clamps coefficients to physics-valid ranges. *Do the numbers make physical sense?*
- **Dynamics Layer**. 3-DOF ODE + compensation inside the NN. *Can we merge physics and learning?*
- **Training Loss**. Only a_y and $\dot{\psi}$ – no extra hardware needed. *Can we scale to fleet data?*
- **Outcome**. Real-time inference of v_y , tyre-road coefficient, etc. *What new states do we unlock?*

Result & Evaluation

Datasets: Public-road “normal” driving and track “extreme” manoeuvres. All data were generated from CarMaker.

Baselines: Purely data-driven LSTM (green) vs *PhysAttenderNet* (yellow); ground truth in black.

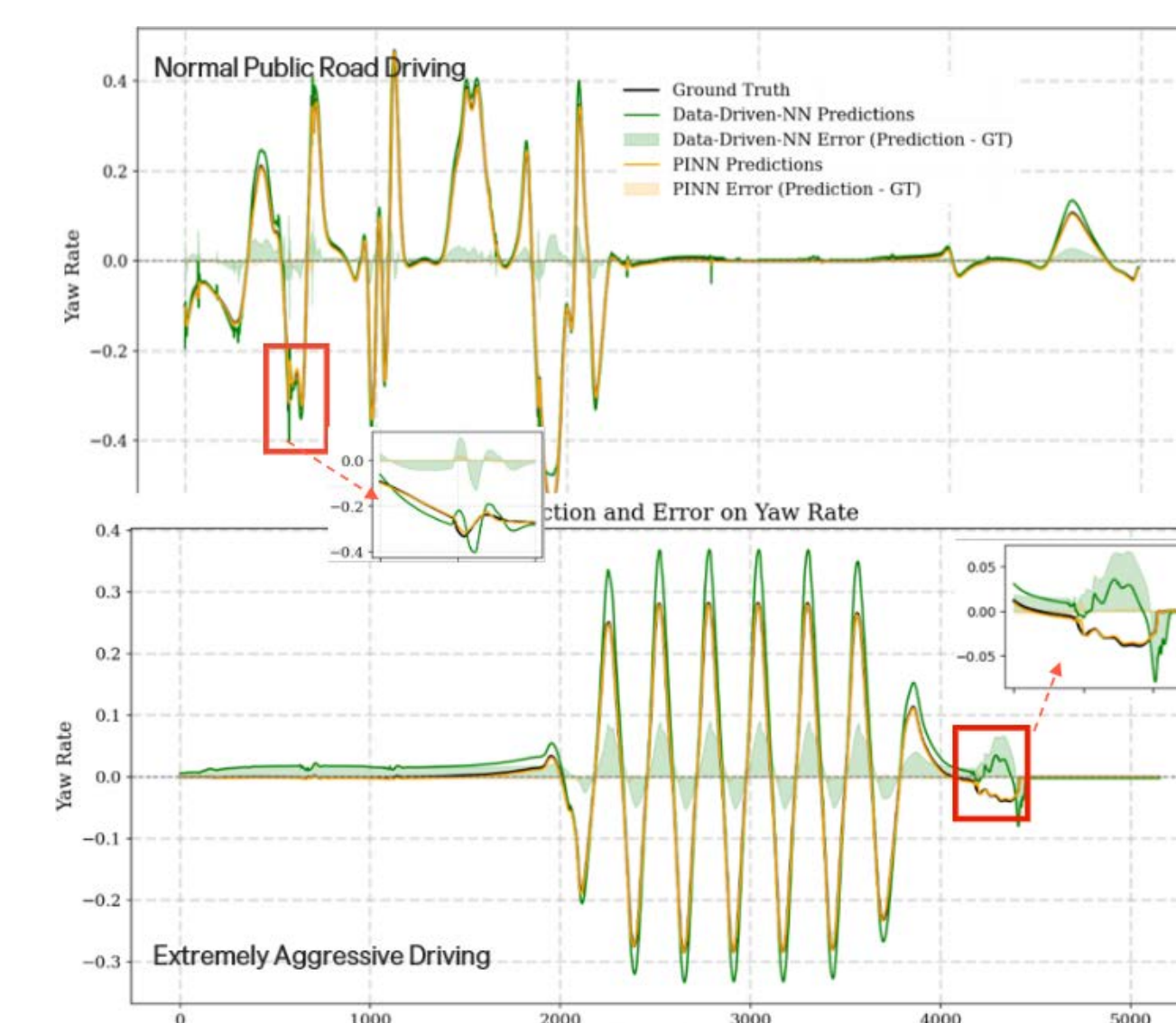

Figure 1. Result on YawRate

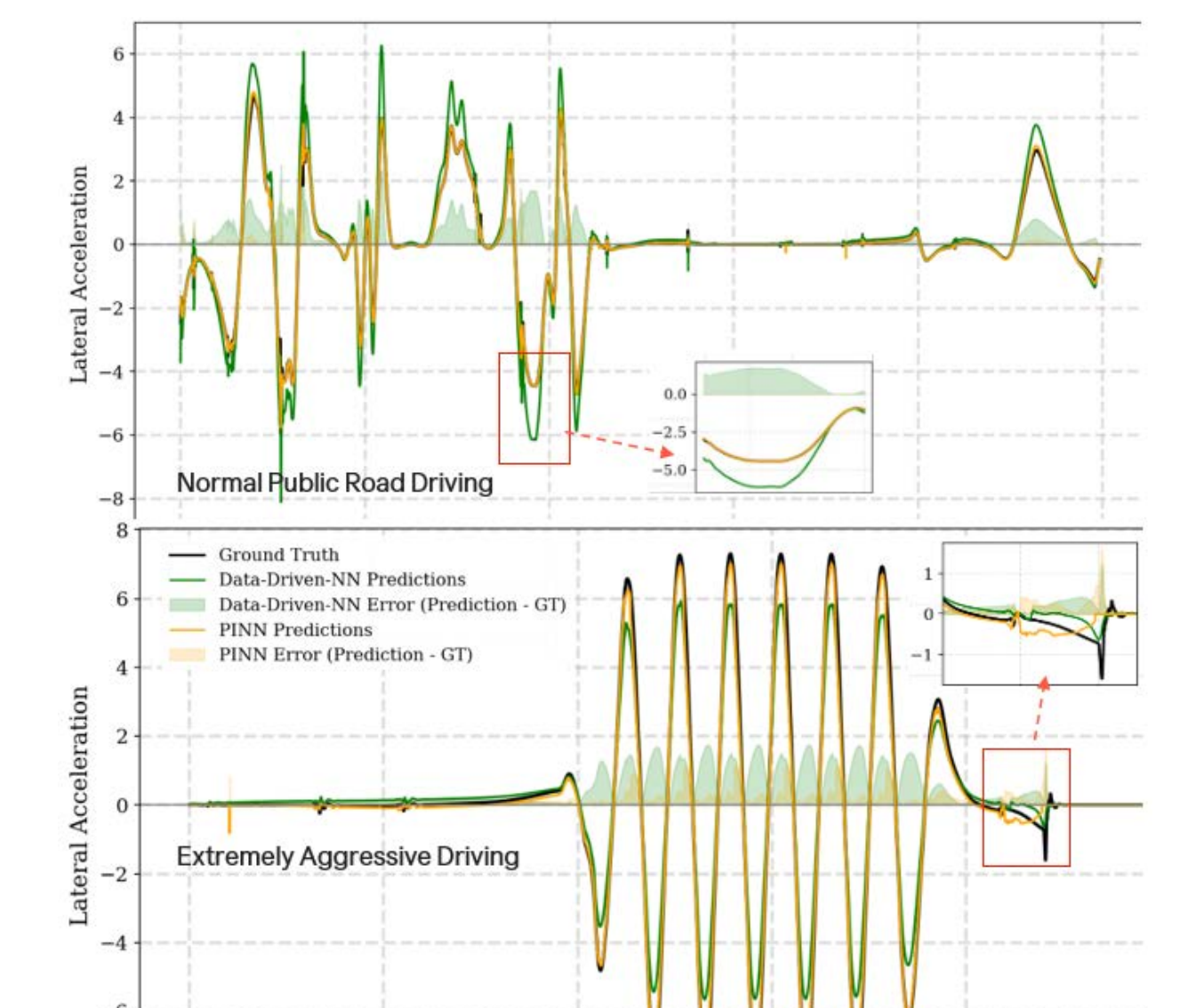

Figure 2. Result on Lateral Acceleration

- **Lateral acceleration a_y** : Lower RMSE and visibly narrower shaded error band across both datasets.
- **Yaw rate $\dot{\psi}$** : Comparable accuracy in normal driving; Data-driven model failed under aggressive inputs, while ours remains stable.
- **Take-away**: Physics constraints curb overfitting and deliver robust generalisation.

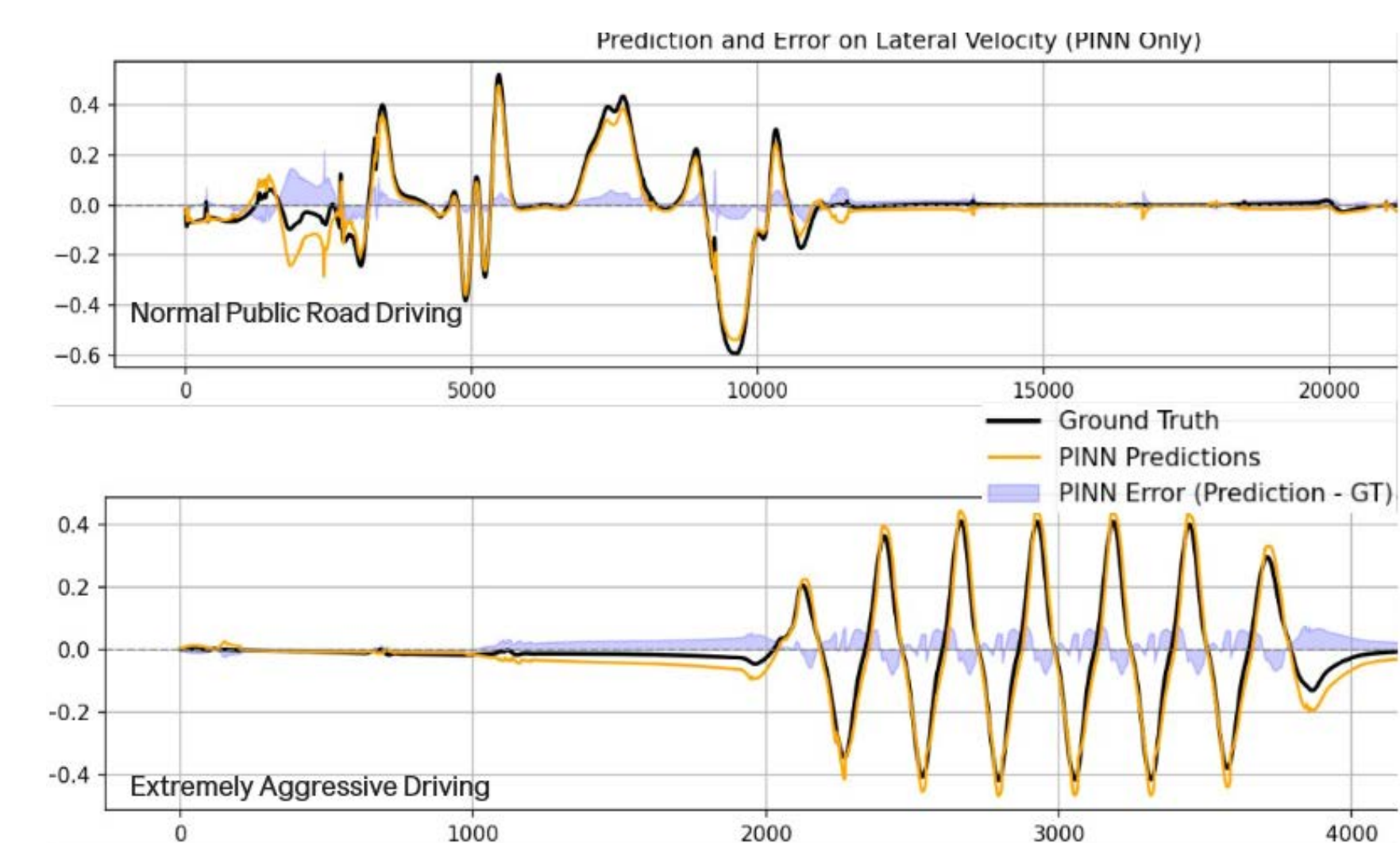

Figure 3. Result on V_y .

- **Challenge**: v_y is *unobservable* with production sensors; no ground truth is available during training.
- **Purely data-driven models**: Cannot learn or output v_y because the target signal is missing.
- **PhysAttenderNet**: Leverages physics constraints to – infer v_y online – without ever seeing its label.

RMSE Comparison (Normal + Aggressive Driving)

Model	Lateral Acc. a_y (m/s ²)	Yaw Rate $\dot{\psi}$ (rad/s)	Lat. Vel. v_y (m/s)
Purely Data-Driven (LSTM)	0.493+0.648	0.0167+0.0303	–
<i>PhysAttenderNet</i>	0.0664+0.243	0.00257+0.0023	0.0389+0.0723

Table 1. Root Mean Square Error (RMSE) comparison. Lower is better. v_y not available from data-driven model.

References

1. H. B. Pacejka and E. Bakker, “The Magic Formula Tyre Model”, Veh. Syst. Dyn., 1992.
2. J. Chrosniak et al., “Deep Dynamics”, IEEE RA-L, 2024.
3. M. Raissi et al., “Physics Informed Deep Learning”, arXiv:1711.10561, 2017.

Poster 5:

Real time model for predictive axle load estimation

Ajhay Babu Jagadeesan Karthik Babu, Mayank
Vijay, KTH and Scania



Master Thesis- Real time model for predictive axle load estimation

Students: Ajhay Babu Jagadeesan Karthik Babu & Mayank Vijay

SVEA Vehicle Dynamics 2025 — Model Exchange for virtual pre series

May 07, 2025



About Us

M.Sc. Vehicle engineering, KTH Royal Institute of Technology

Automotive Track in the school of Engineering Sciences

KTH Supervisor/Examiner: Lars Drugge

Scania CV AB TGRAMBB Brake Functions group

Manager: Alexander Müllersdorf

Supervisors: Henrik Johansson & Ivar Rockström

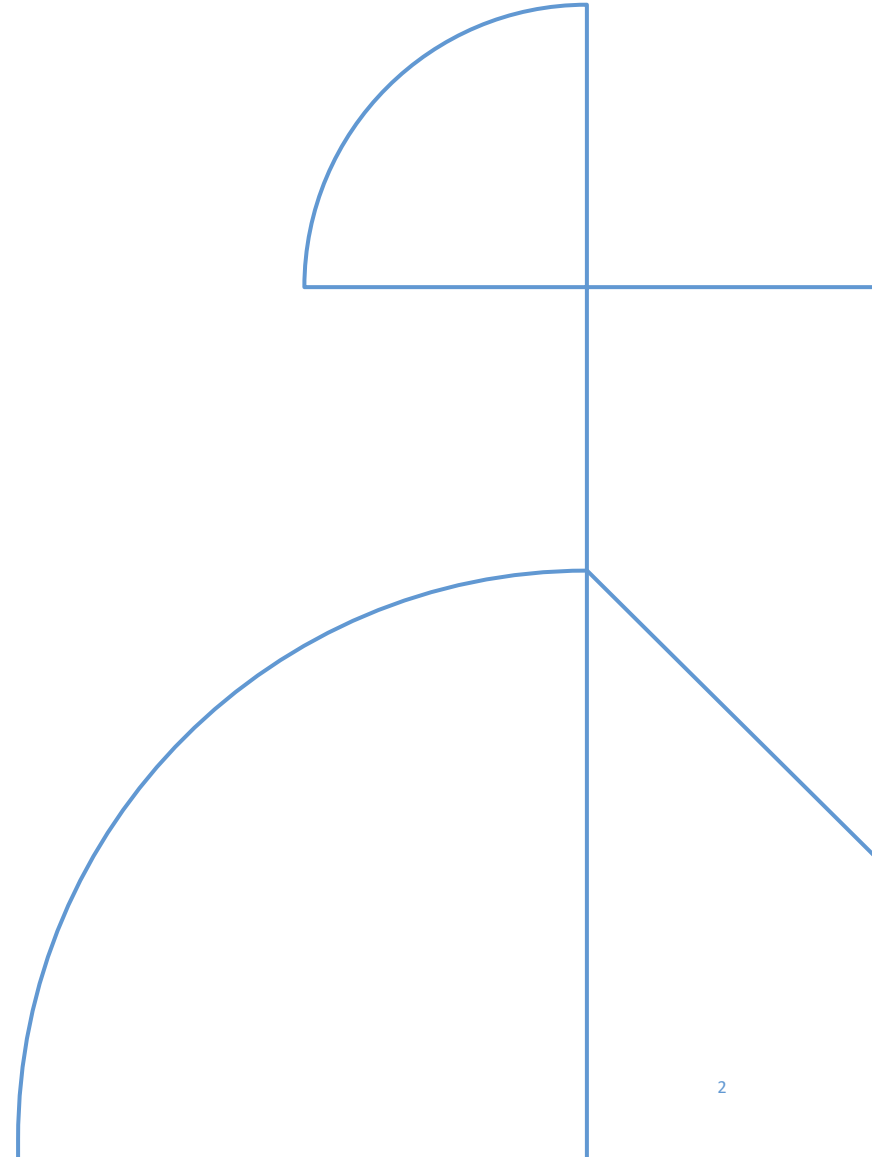

Aim of the Thesis and Outcomes

- To develop a **real-time estimation framework** for predicting axle loads and dynamic load transfer on a truck's **driven axle**, with a focus on **auxiliary braking** scenarios.
- This involves creating a **half truck model** capable of estimating axle normal loads across varying truck configurations in **real time**, using a **recursive error-based learning algorithm** for adaptive prediction.
- The thesis also aims to implement and test a **vehicle-integrated prototype** of this function and **validate its performance** against suspension **bellow pressure** measurements.

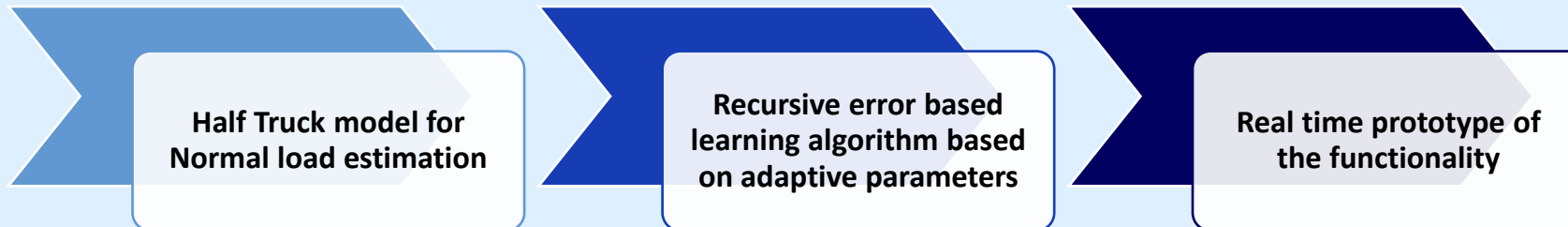
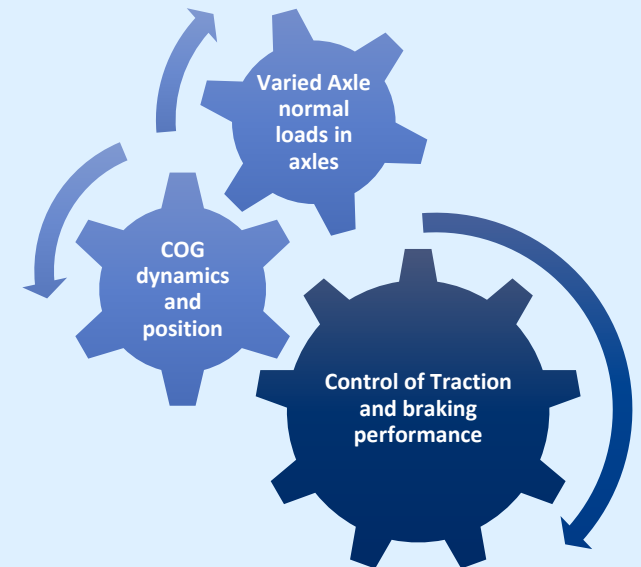
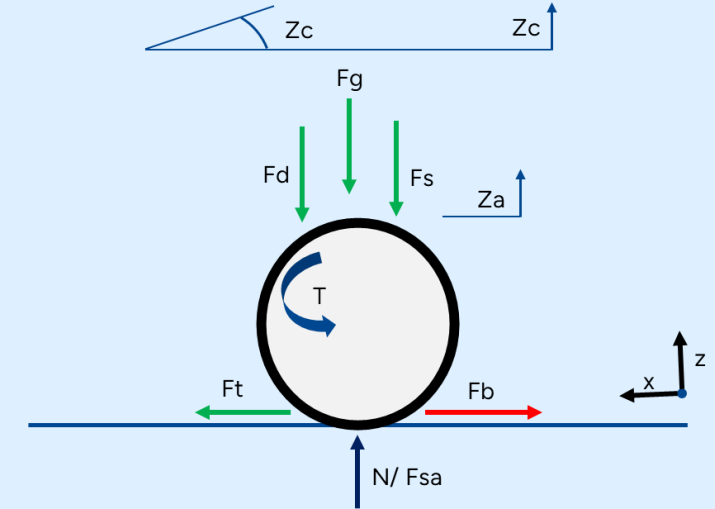

Model Simulation Results

Bellow Pressure

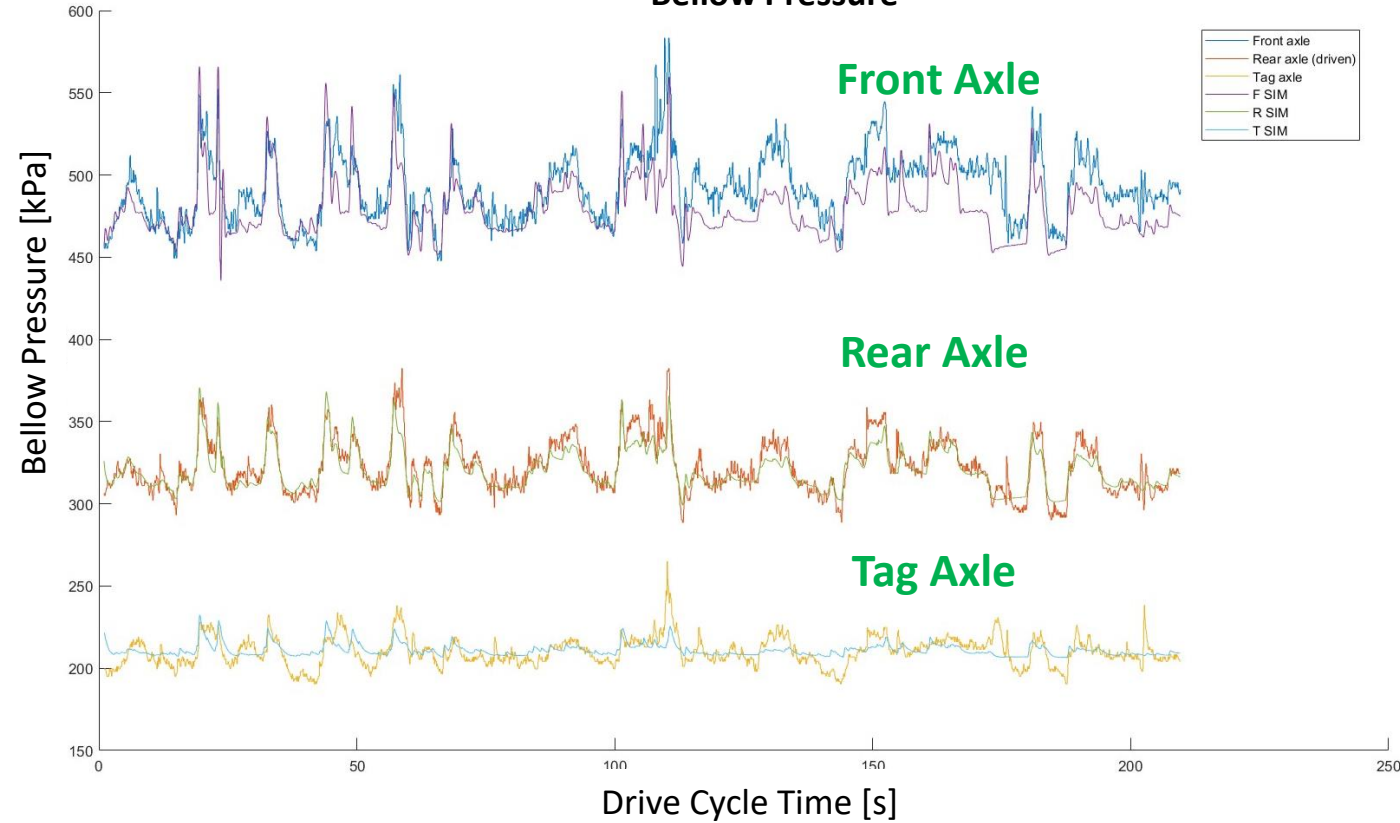

Front Axle Error--- 19.3%--- 18.66 kPa--- 131.23 kg

Rear Axle Error--- 3.573%--- 7.154 kPa--- 35.73 kg

Tag Axle Error--- 4.82%--- 7.09 kPa--- 36.14 kg

Axle Normal Load

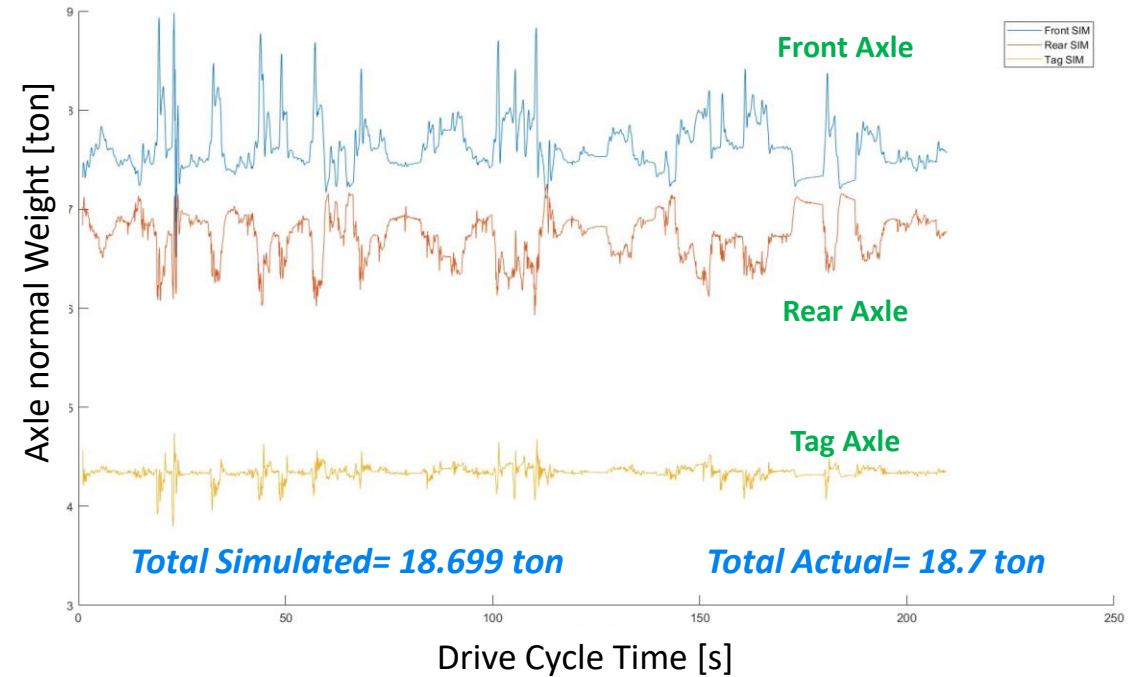

Parametric Study

- Spring Stiffness Variation (K)
- Damper coeff. variation (C)
- Air bellow Area (bellow_area)
- Distance Between Rear And Tag Axle (l3c)

Real Time Learning Algorithm for Parameter Estimation

Why need a learning algorithm even when there is a defined model? --- Unmodelled, adaptive for configurations, real time

Online parameter estimator Goal → minimizes error between $sim_pressure$ & $measured_pressure$

“Not all non-linearities are a trouble in modelling, some can be leveraged”

Non Linear adaptations: Air spring stiffness & bellow area

Heuristic Learning on the move:

Dynamic state-dependent **Suspension Parameter Adaptation** for Accurate Axle Load Estimation Based on **Error Magnitude** and **Directionality with state dependency**

Adaptive prediction with UKF:

State-Sensitive Stiffness adaptation with **UKF** and **Simulink** based pressure feedback

RMSE Evolution

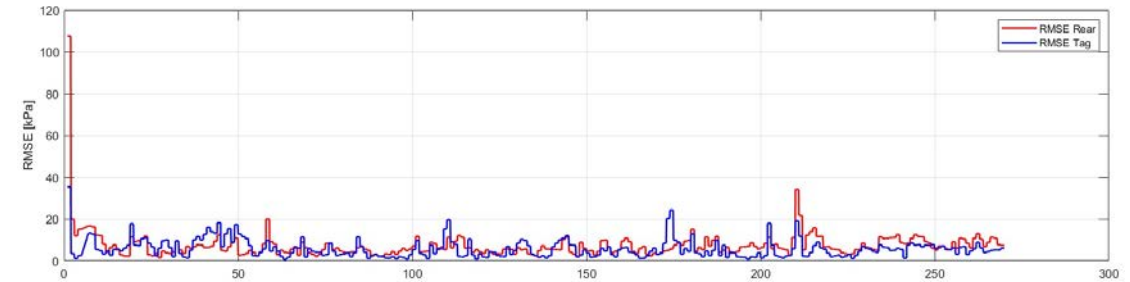

Air spring stiffness Evolution

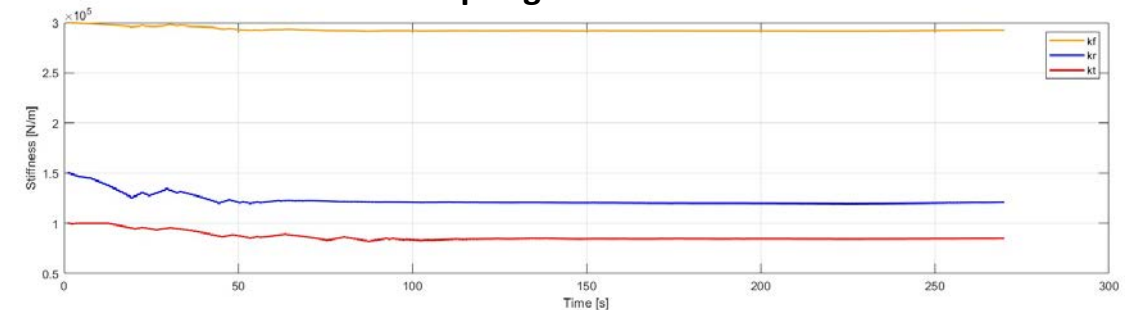

Rear Axle Error--- 7.88 kPa--- 39.92 kg--- 3.99%

Tag Axle Error--- 7.01 kPa--- 36.23 kg--- 4.83%

Vehicle Integrated Testing and Steps

- Simulink model **discretized** and compiled via Vector CANape for **embedded deployment**.
- Real-time integrated **test cases** framed for **model validation**.
- Outcomes establish a foundation for **onboard axle load functionalities**.

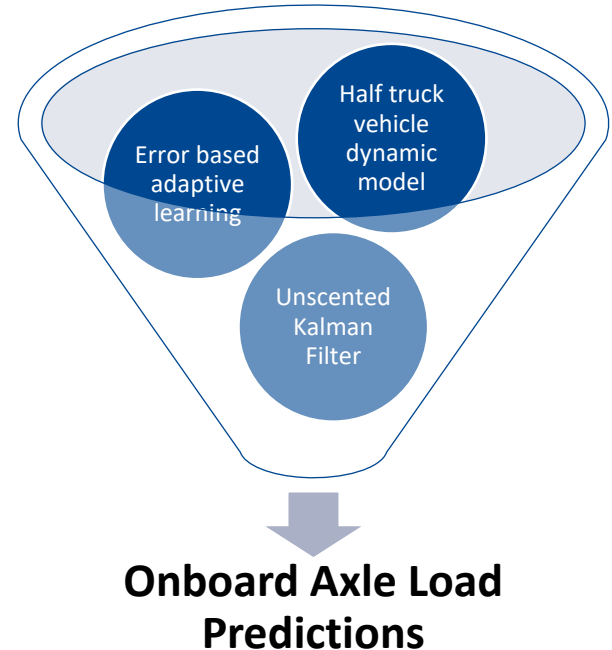



Thank You!

Ajhay Babu Jagadeesan Karthik Babu (abjkb@kth.se)
 Mayank Vijay (mayankv@kth.se)

M.Sc. Vehicle Engineering, KTH Royal Institute of Technology
 Scania CV AB, TGRAMBB Brake Functions Team

Aim: To develop a real-time estimation framework for predicting axle loads and dynamic load transfer on a truck's driven axle, with a focus on auxiliary braking scenarios. This involves creating a half truck model capable of estimating axle normal loads across varying truck configurations in real time, using a recursive error-based learning algorithm for adaptive prediction. The thesis also aims to implement and test a vehicle-integrated prototype of this function and validate its performance against suspension bellows pressure measurements.

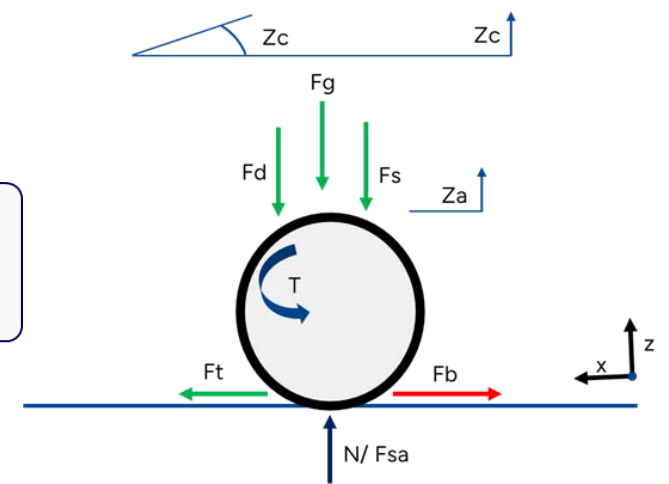
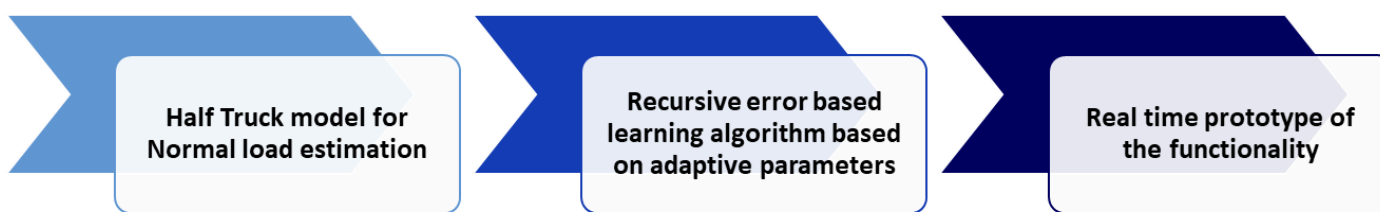

Scania's tests observation
 "Achieving a specified slip ratio in a braking state requires a lower auxiliary braking torque compared to the torque needed in an acceleration state"

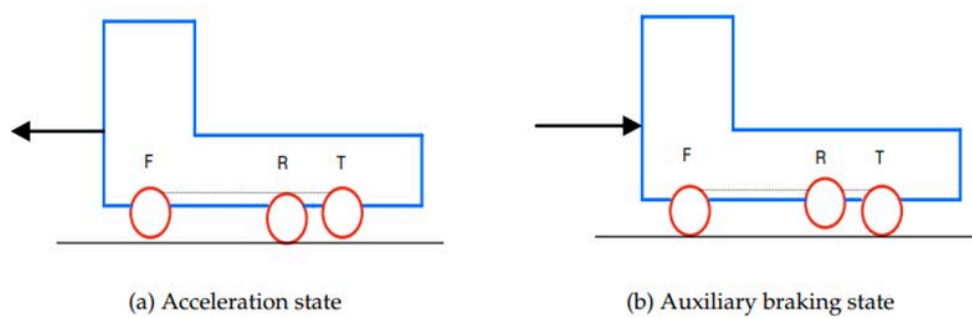

Due to Load Transfer

In acceleration: More grip on R → needs **more torque** for same slip.

In braking: Less grip on R → needs **less torque** for same slip.

- Optimal tyre slip control
- Improved braking control (ABS, ESP)
- Avoids overloading axles and more tire life
- Axle load management leads to improved stability, traction performance and minimized impacts on infrastructure
- Prevents suspension failure and pavement damage

Pros of estimating Normal loads in each axle

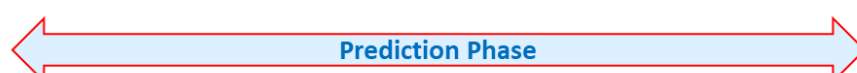
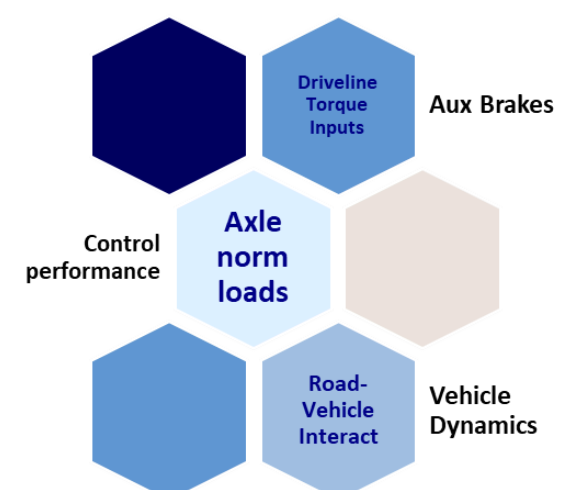
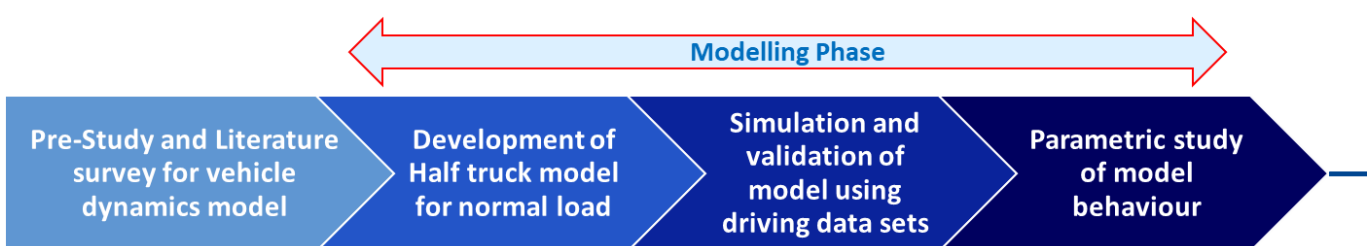

Ajhay Babu Jagadeesan Karthik Babu (abjkb@kth.se)
Mayank Vijay (mayankv@kth.se)

M.Sc. Vehicle Engineering, KTH Royal Institute of Technology
Scania CV AB, TGRAMBB Brake Functions Team

Simulation results

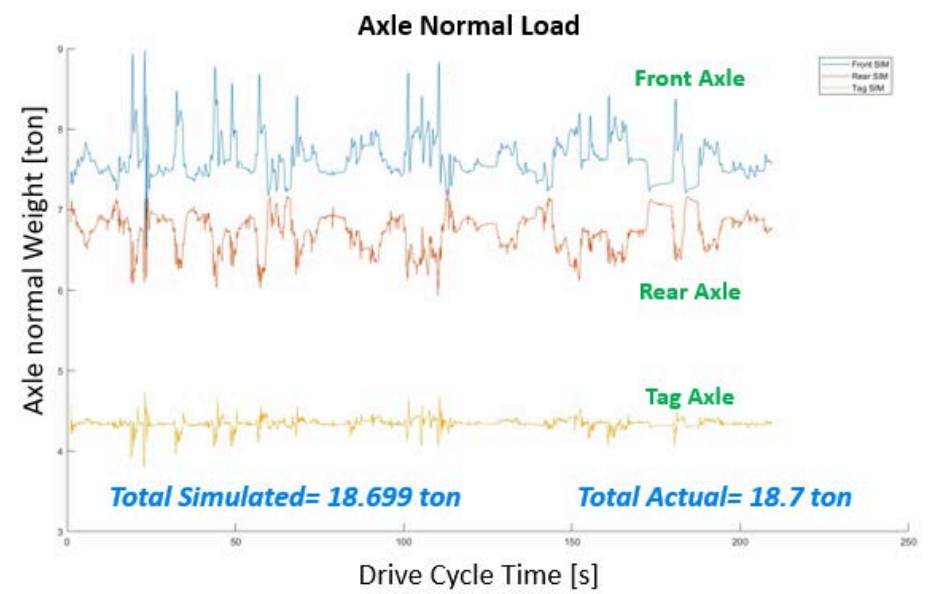
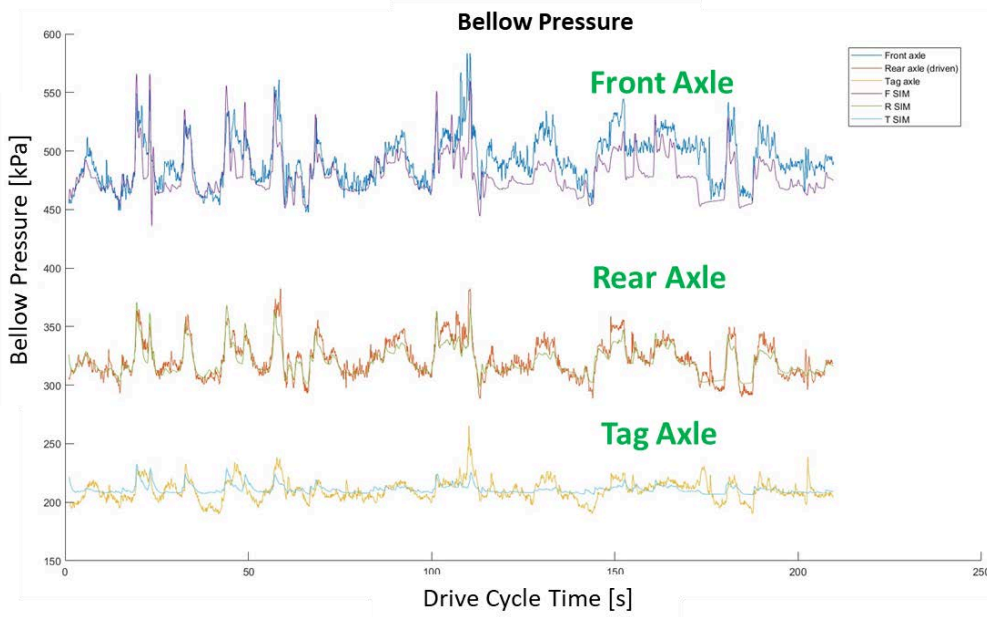

Parametric Study

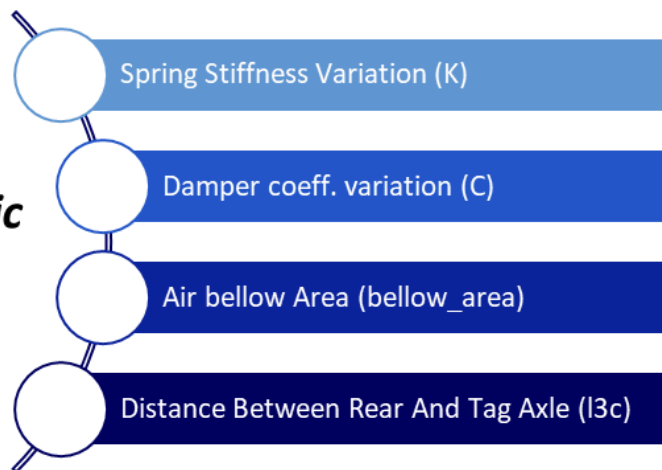

Front Axle Error--- 19.3%--- 18.66 kPa--- 131.23 kg
Rear Axle Error--- 3.573%--- 7.154 kPa--- 35.73 kg
Tag Axle Error--- 4.82%--- 7.154 kPa--- 36.14 kg

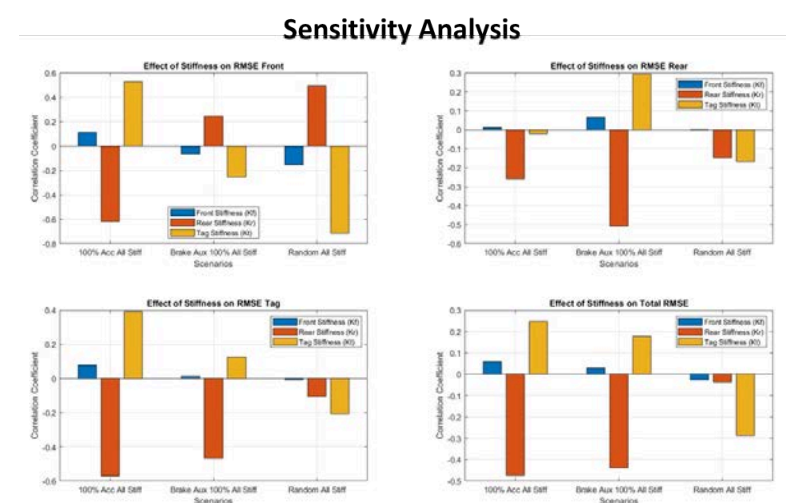
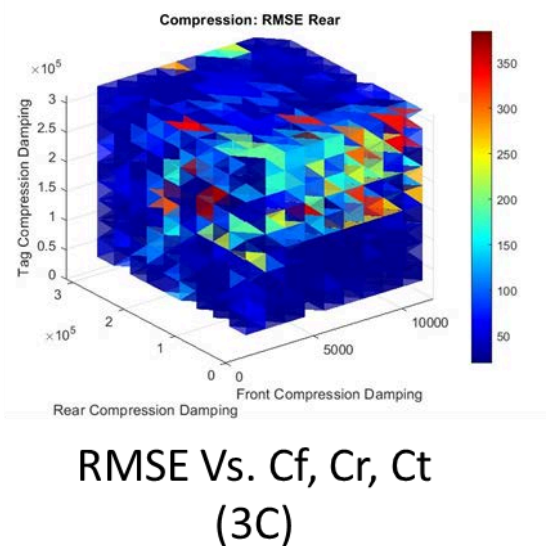
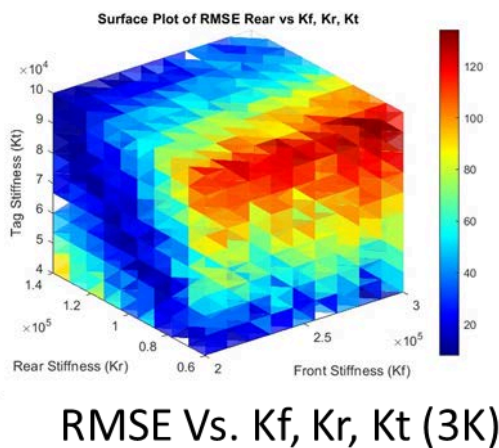

Random Driving scenario- Pressure validation results

Axle	RMSE_kPa	Percent_Error	Detrended_R2	Residual_Mean_kPa	Residual_Std_kPa	Bias
	kPa	%	No unit	kPa	kPa	No unit
Front	18,667	2,712	0,614	13,369	13,029	Underprediction
Rear	7,154	0,719	0,82	2,32	6,767	Underprediction
Tag	7,289	0,303	0,31	-0,637	7,261	Overprediction
Jan 25 Random driving -----Total Axle Load- 18.69934 tons						



Master Thesis- Real time model for predictive axle load estimation



Ajhay Babu Jagadeesan Karthik Babu (abjkb@kth.se)
Mayank Vijay (mayankv@kth.se)

M.Sc. Vehicle Engineering, KTH Royal Institute of Technology
Scania CV AB, TGRAMBB Brake Functions Team

Learning Algorithm

Why need a learning algorithm even when there is a defined model?

- Real systems have noise, disturbances, and unmodeled dynamics
- Estimators help correct for these using real-time data
- Combine real sensor data with model outputs to have an accurate axle load estimation

Online parameter estimator Goal → minimizes error between $sim_pressure$ & $measured_pressure$

Non Linear adaptations: Air spring stiffness & bellow area

”Not all non-linearities are a trouble in modelling, some can be leveraged”

Heuristic Learning on the move:

Dynamic state-dependent Suspension Parameter Adaptation for Accurate Axle Load Estimation Based on Error Magnitude and Directionality with state dependency

Adaptive prediction with UKF:

State-Sensitive Stiffness adaptation with UKF and Simulink based pressure feedback

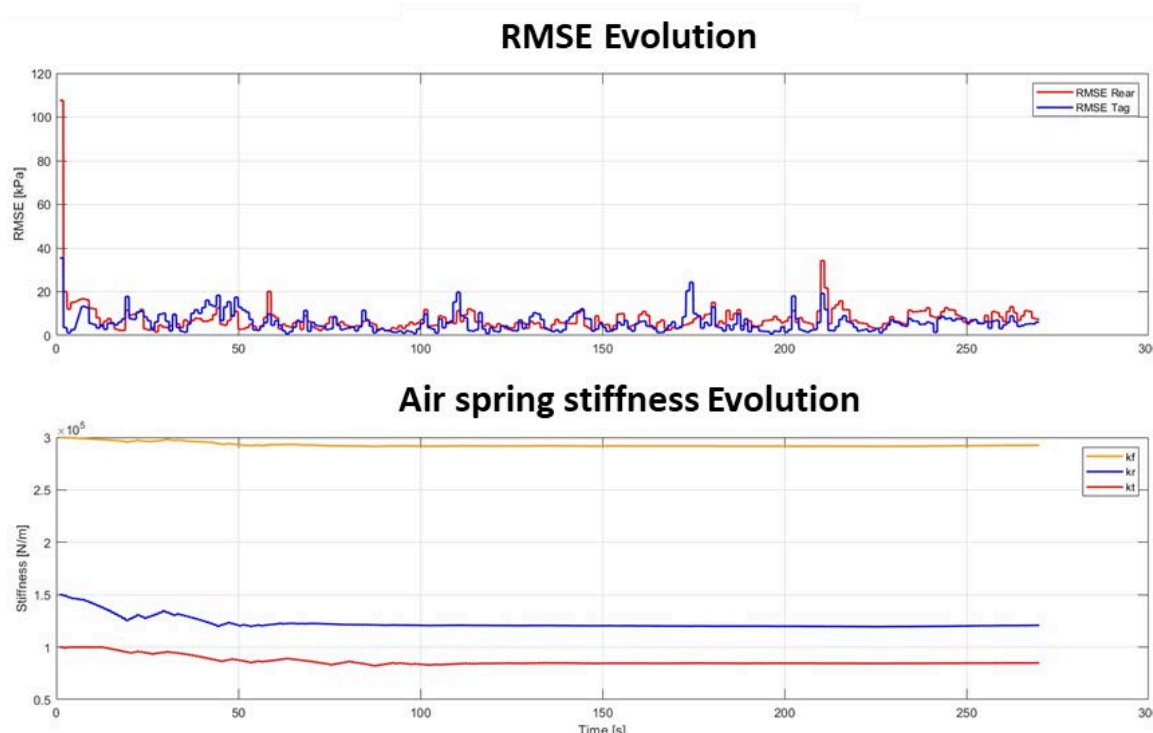
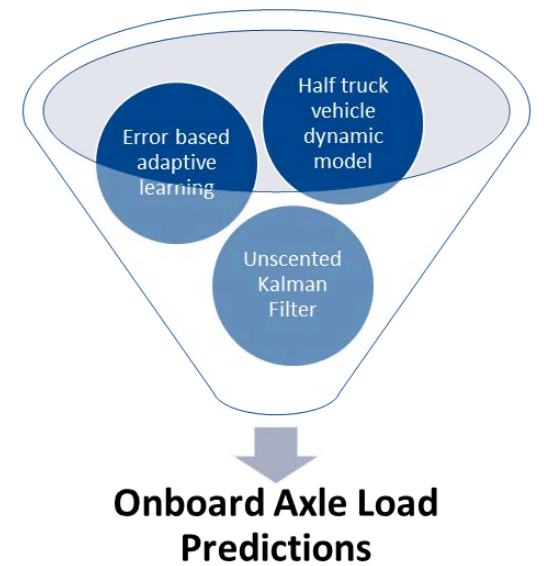

Rear Axle Error--- 7.88 kPa--- 39.92 kg--- 3.99%

Tag Axle Error--- 7.01 kPa--- 36.23 kg--- 4.83%